

251B



Owner's Manual Supplement

www.seafoxboats.com

SEA FOX BOAT'S DISCLAIMER

The following Owner's Manual is provided for information and educational purposes only and is not intended to offer or provide legal advice or create a contractual relationship between Sea Fox Boat Company and the owner of any Sea Fox brand vessel. Please beware that as a vessel owner you have non-delegable responsibilities regarding the safety, maintenance, fitness, and operation of your vessel and the extent of such responsibilities is ultimately determined by Federal law and regulations, the general maritime law of the United States, the laws and regulations of the states and territories of the United States, or the laws and regulations of the country where you operate your vessel. To fully understand your responsibilities as a vessel owner, and before operating or letting any third-party operate your vessel, we recommend that you consult the services of a qualified lawyer in admiralty and maritime law.

TABLE OF CONTENTS

Introduction	3	Electrical Schematics	14
Specifications	3	Main Harness	14
Designated Occupant Seating	4	Switch Panel	15
Safety Decals	5	Breaker Panel	16
Plumbing Schematics	7	Deck Harness	17
Fuel System	7	Hardtop Harness	18
Bilge System	8	Underwater Lights Harness	19
Fresh Water System	9	Trolling Motor Harness	20
Raw Water System	10	Battery Wiring	21
Drains	11		
Livewell System	13		

This Page Intentionally Left Blank

INTRODUCTION

Congratulations and Welcome Aboard! With so many boat brands to choose from, we want to congratulate you on your decision to choose Sea Fox Boats. For more than 28 years, Sea Fox offers the finest hand-crafted saltwater boats carefully balanced with the build-quality, features, styling and performance for the fairest price. Our passion for boating is evident in every model we make and we appreciate that you've noticed the Sea Fox difference.

We share your love for the moments spent on the water with friends and family, which is why every Sea Fox boat offers a unique blend of fishing/family options, technologies and innovative features. Your choice of a Sea Fox affirms that you have performed your research and compared the value of your model with the competition.

Whether you are new to the boating lifestyle or an old salt, we ask that **you and all other operators** read the owner's manual, this supplement, and all other literature provided with the boat **before** operating the boat or any equipment. We also recommend that all operators enroll in a boating safety course available online - see References and Contact Information in this section for education resources online.

This supplement contains model-specific information not included with the owner's manual. This manual is not intended to be a replacement for specific product literature provided by engine, accessory or other major equipment manufacturers, but rather to supplement that information.

Because of our philosophy of continuous product improvement, this manual serves as a general guide only, so the specifications and illustrations used may not match the equipment on your boat and are intended only as general reference views.

We welcome you to the Sea Fox family and wish you many years of boating enjoyment!

SPECIFICATIONS

Max. Weight Capacity	2200 lbs (1000 kg)
Persons	8
Persons Weight	1200 lbs (544 kg)
Max. HP	300 hp (224 kw)
L.O.A.	24' 4" (7.41 m)
Beam	8' 6" (2.59 m)
Draft	14 in. (0.36 m)
Height, Keel to Top (Light Folded)	106 in. (2.69 m)
Bridge Clearance Hard Top	92 in. (2.34 m)
Max. Weight Boat (w/ Fluids, Largest HP)	5301 lbs (2404 kg)
Fuel Tank Capacity	72 gal (273 L)
Freshwater Tank Capacity	6 gal (23 L)
Holding Tank Capacity	N/A

DESIGNATED OCCUPANT SEATING

Be sure all passengers are properly seated in designated seating positions and not riding on the bow, bow pulpit, deck, gunwale or rear sun deck while underway. Passengers must use hand-holds and use caution when riding in the bow. Move to the aft passenger seats during rough water operation or if visibility is restricted.

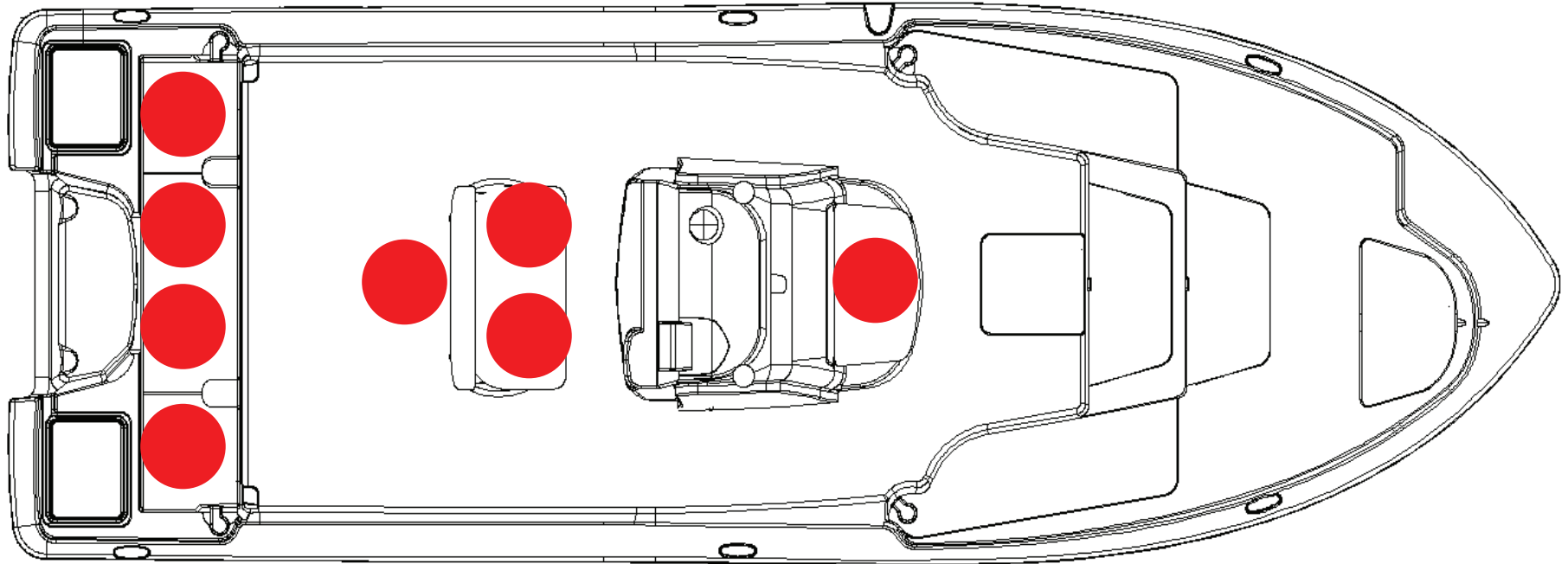

● = Seat position

SFOX-0015

SAFETY DECALS

4 **BATTERY CHARGER**

4 **WARNING**
Operating, servicing and maintaining a recreational marine vessel can expose you to chemicals including engine exhaust, carbon monoxide, phthalates, and lead, which are known to the State of California to cause cancer and birth defects or other reproductive harm. To minimize exposure, avoid breathing exhaust, service your vessel in a well-ventilated area and wear gloves or wash your hands frequently when servicing this vessel. For more information go to www.P65warnings.ca.gov/marine.

6 **DANGER**
ROTATING PROPELLER CAN CAUSE SERIOUS INJURY OR DEATH. SHUT OFF MOTOR WHEN NEAR PERSONS IN WATER.

6 **DANGER**
ROTATING PROPELLER CAN CAUSE SERIOUS INJURY OR DEATH. SHUT OFF MOTOR WHEN NEAR PERSONS IN WATER.

1 **WARNING**
Failure to follow these warnings could cause SERIOUS INJURY OR DEATH.

- REMAIN PROPERLY SEATED AND HOLD ON to available handrails while boat is moving to avoid falling overboard or being ejected from the boat. Do not sit on seat backs, gunwales or outermost deck edges.
- WEAR U.S. COAST GUARD APPROVED LIFE JACKETS.
- DO NOT OVERLOAD THE BOAT. OCCUPANTS AND GEAR MUST BE PROPERLY AND EVENLY DISTRIBUTED fore and aft, and on both sides of the boat. Improper loading and/or overloading may result in poor handling, sudden loss of control, swamping and/or capsizing.
- REFER TO AND OBEY THE DESIGNATED OCCUPANT SEATING POSITIONS that are indicated by the manufacturer for your specific model.
- OBEY THE OPERATOR at all times.
- DO NOT RESTRICT THE OPERATOR'S VISION.
- DO NOT DEPART THE VESSEL without informing the operator.

5 **WARNING**
Failure to follow these warnings could cause SERIOUS INJURY OR DEATH.

- REMAIN PROPERLY SEATED AND HOLD ON to available handrails while boat is moving to avoid falling overboard or being ejected from the boat. Do not sit on seat backs, gunwales or outermost deck edges.
- WEAR U.S. COAST GUARD APPROVED LIFE JACKETS.
- DO NOT OVERLOAD THE BOAT. OCCUPANTS AND GEAR MUST BE PROPERLY AND EVENLY DISTRIBUTED fore and aft, and on both sides of the boat. Improper loading and/or overloading may result in poor handling, sudden loss of control, swamping and/or capsizing.
- REFER TO AND OBEY THE DESIGNATED OCCUPANT SEATING POSITIONS that are indicated by the manufacturer for your specific model.
- OBEY THE OPERATOR at all times.
- DO NOT RESTRICT THE OPERATOR'S VISION.
- DO NOT DEPART THE VESSEL without informing the operator.

Manufactured by

SEA FOX

BOAT WORKS

6 **ABYC**
Boating Safety - Built In
www.abyc.org
MEMBER

6 **PROTECTED DESIGN**
SEA FOX
BOAT WORKS
U.S. LIBRARY OF CONGRESS

6 **NO WOOD!
NO ROT!**

6 **RAW WATER**

6 **FRESH WATER**

6 **NON POTABLE WATER**

6 **NON POTABLE WATER**

1 **WARNING**
WARNING:
AVOID SERIOUS INJURY OR DEATH. OCCUPANT MAY FALL OR BE EJECTED FROM SEAT. DO NOT OCCUPY SEAT WHEN SPEED EXCEEDS 5 MPH.

1 **WARNING**
WARNING:
AVOID SERIOUS INJURY OR DEATH. OCCUPANT MAY FALL OR BE EJECTED FROM SEAT. DO NOT OCCUPY SEAT WHEN SPEED EXCEEDS 5 MPH.

4 **WARNING**
Failure to follow these warnings could cause severe injury or death

- WEAR SAFETY LANYARD at all times while operating boat to prevent unmanned boat operation.
- NEVER OPERATE WHILE UNDER THE INFLUENCE of drugs or alcohol.
- DO NOT OVERLOAD THE BOAT. ENSURE THAT WEIGHT IS PROPERLY AND EVENLY DISTRIBUTED fore and aft and on both sides of the boat to avoid poor handling, sudden loss of control, swamping and/or capsizing.
- PASSENGERS SHOULD WEAR U.S. COAST GUARD APPROVED LIFE JACKETS.
- MAKE SURE THAT ALL PASSENGERS ARE PROPERLY SEATED WHILE UNDERWAY. To avoid passengers falling overboard or being ejected from the boat, do not allow passengers to sit on seat backs, gunwales or outermost deck edges while boat is moving.
- REDUCE SPEED BEFORE ATTEMPTING SUDDEN OR SHARP TURNS.
- AND MAINTAIN SAFE SPEEDS for water conditions and environment at all times. Maneuverability at high speeds is limited, and sudden turns may cause loss of boat control.
- KEEP PROPER LOOKOUT AND SAFE DISTANCE for the conditions at all times to avoid collisions.
- OBEY APPLICABLE NAVIGATION RULES AND BOATING LAWS.
- USE CAUTION AND PROPER LIGHTING during nighttime boating and boating in adverse weather.
- READ THE OWNER'S MANUAL AND COMPLETE THE BOATER'S PRE-OPERATION CHECKLIST prior to boat operation.

6 **DANGER**
Carbon monoxide (CO) can cause brain damage or death.
Engine and generator exhaust contains odorless and colorless carbon monoxide gas.
Carbon monoxide will be around the back of the boat when engines or generators are running.
Move to fresh air, if you feel nausea, headache, dizziness, or drowsiness.

6 **DANGER**
Carbon monoxide (CO) can cause brain damage or death.
Engine and generator exhaust contains odorless and colorless carbon monoxide gas.
Carbon monoxide will be around the back of the boat when engines or generators are running.
Move to fresh air, if you feel nausea, headache, dizziness, or drowsiness.

5 **CAUTION**
TO AVOID DAMAGE TO ENGINE, LOWER SEAT BACK REST BEFORE TRIMMING ENGINE IN TRAILERING POSITION.

2 **WARNING**
CONTENTS CAN BE UNDER PRESSURE. AVOID SERIOUS INJURY OR DEATH FROM FIRE OR EXPLOSION. OPEN SLOWLY IN WELL VENTILATED AREA. NO SMOKING OR OPEN FLAMES.

4 **MAXIMUM CAPACITIES**
8 PERSONS OR 1200 LBS.
2200 LBS. PERSONS, MOTOR, GEAR
300 H.P. MOTOR
THIS BOAT COMPLIES WITH THE U.S. COAST GUARD SAFETY STANDARDS IN EFFECT ON THE DATE OF CERTIFICATION
SEA FOX BOAT COMPANY, INC.
MONCK'S CORNER, S.C. KS6A

6 **WARNING**
CAUTION: BEFORE TRIMMING THE ENGINE INTO THE LOCK/UP POSITION, JACKPLATE MUST BE ELEVATED 3". FAILURE TO FOLLOW THIS PROCEDURE MAY RESULT IN DAMAGE TO ENGINE/BOAT.

6 **NOTICE**
THIS BOAT IS EQUIPPED WITH AN OPTIONAL DIRECT OVERBOARD DISCHARGE VALVE. DISCHARGING OF SEWAGE DIRECTLY OVERBOARD IS FOR USE WHERE APPROVED ONLY.

5 **WARNING**
Leaking fuel is a fire and explosion hazard.
Avoid serious injury or death from fire or explosion from leaking fuel. Inspect system for leaks at least once a year.

4 **WARNING**
CARBON MONOXIDE (CO) CAN CAUSE BRAIN DAMAGE OR DEATH.
-Carbon monoxide can be present in the cabin.
-Signs of carbon monoxide poisoning include nausea, headache, dizziness, drowsiness, and lack of consciousness.
MOVE TO FRESH AIR if anyone shows signs of carbon monoxide poisoning.
USE AVAILABLE HANDRAILS AND HANDHOLDS while moving about the cabin and while the boat is in motion to avoid falling.

4 **WARNING**
Rotating propeller may cause serious injury or death. Shut off engine when near persons in the water.
Carbon monoxide (CO) can cause brain damage or death. Engine and generator exhaust contains odorless and colorless carbon monoxide gas. Signs of carbon monoxide poisoning include nausea, headache, dizziness, drowsiness, and lack of consciousness. Get fresh air if anyone shows signs of carbon monoxide poisoning.
See Owner's Manual for information regarding carbon monoxide poisoning.
Leaking fuel is a fire and explosion hazard. Avoid serious injury or death from fire or explosion from leaking fuel. Inspect system for leaks at least once a year.

SEA FOX BOAT COMPANY
MEETS U.S. EPA EVAL STANDARDS USING CERTIFIED COMPONENTS

230350 251 Bay Fox Decal Kit Rev 2

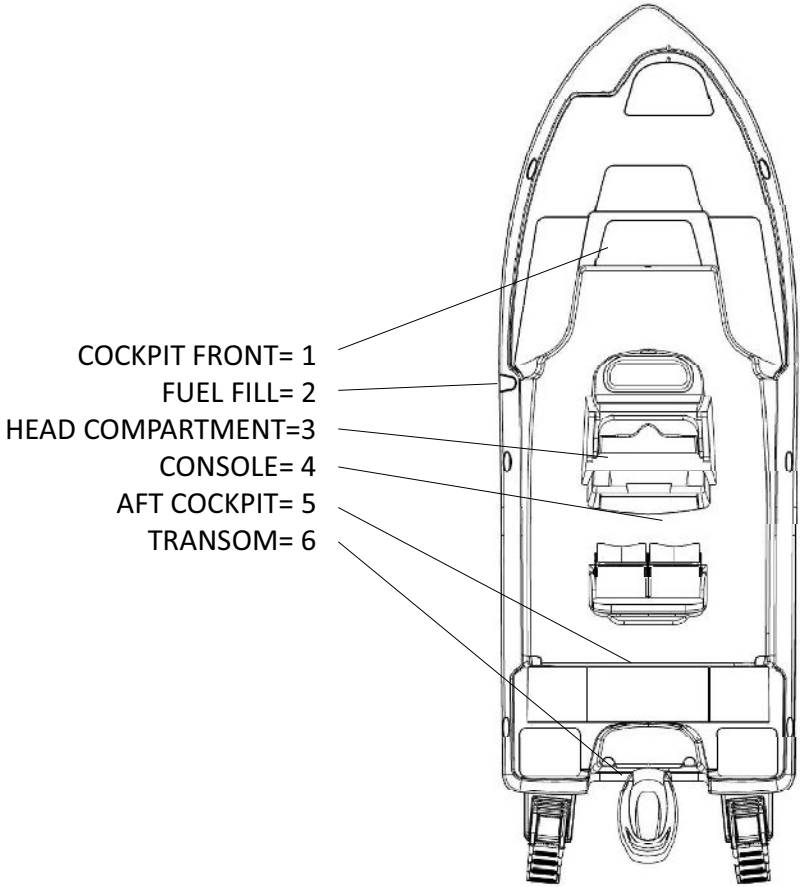

PLUMBING SCHEMATICS

FUEL SYSTEM

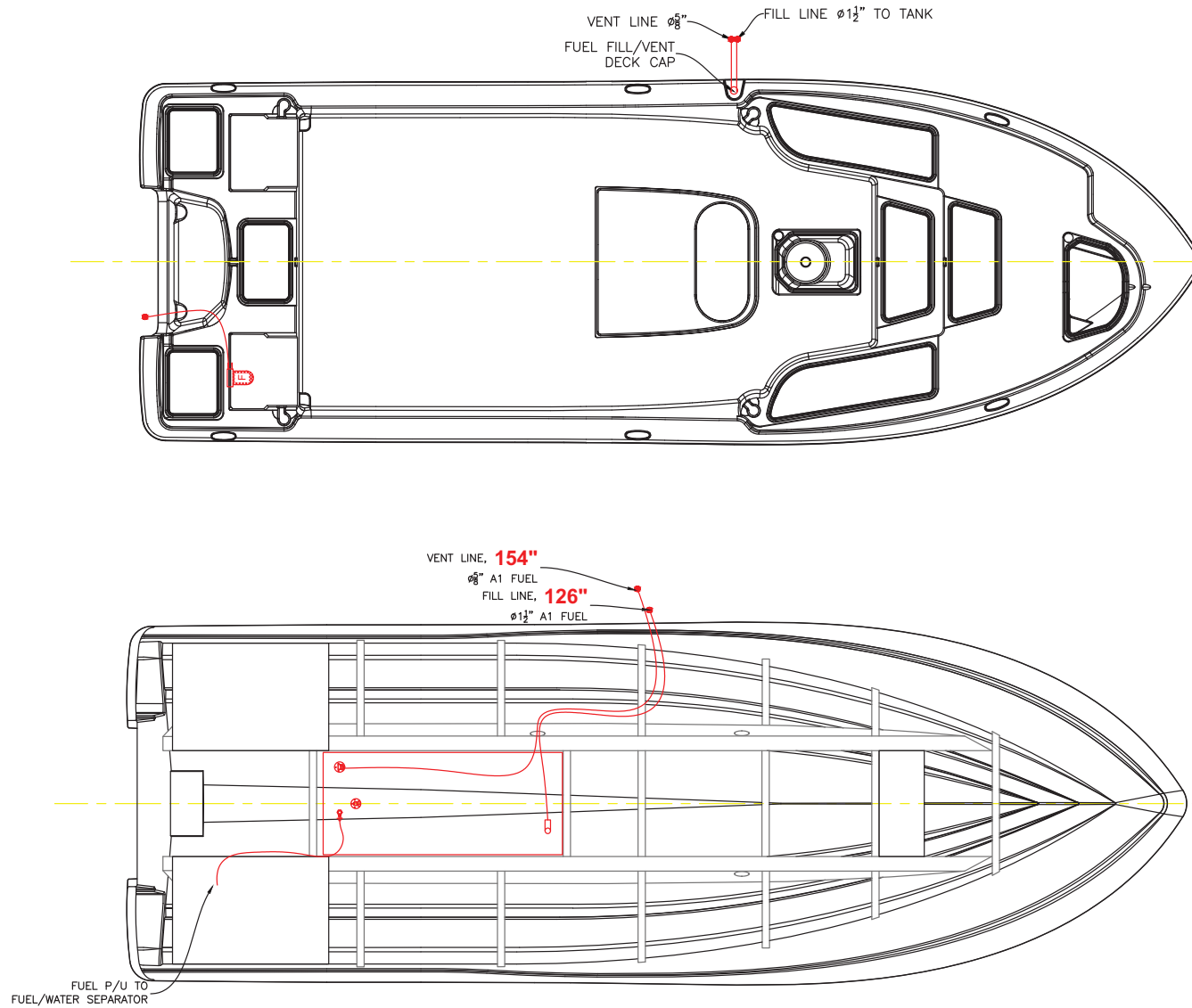

BILGE SYSTEM

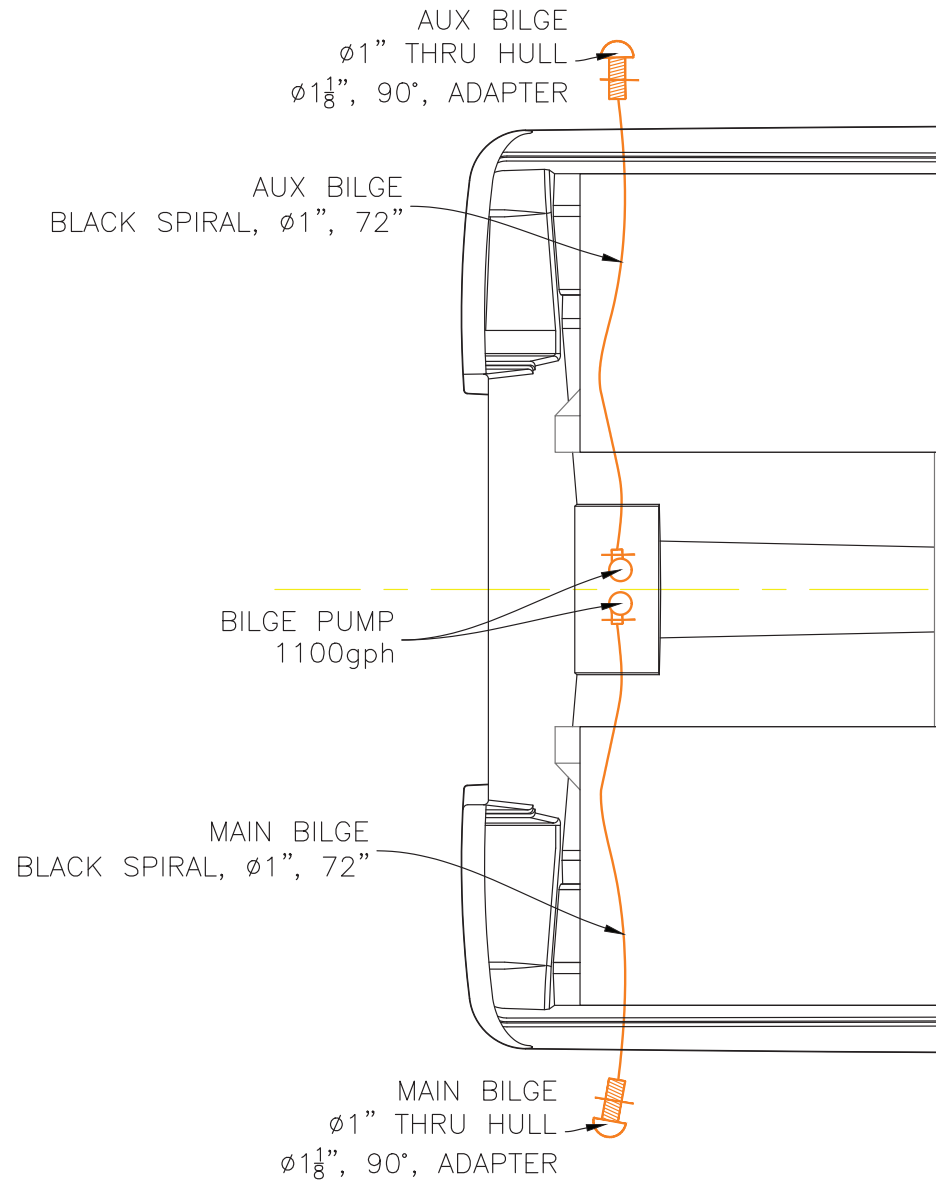

FRESH WATER SYSTEM

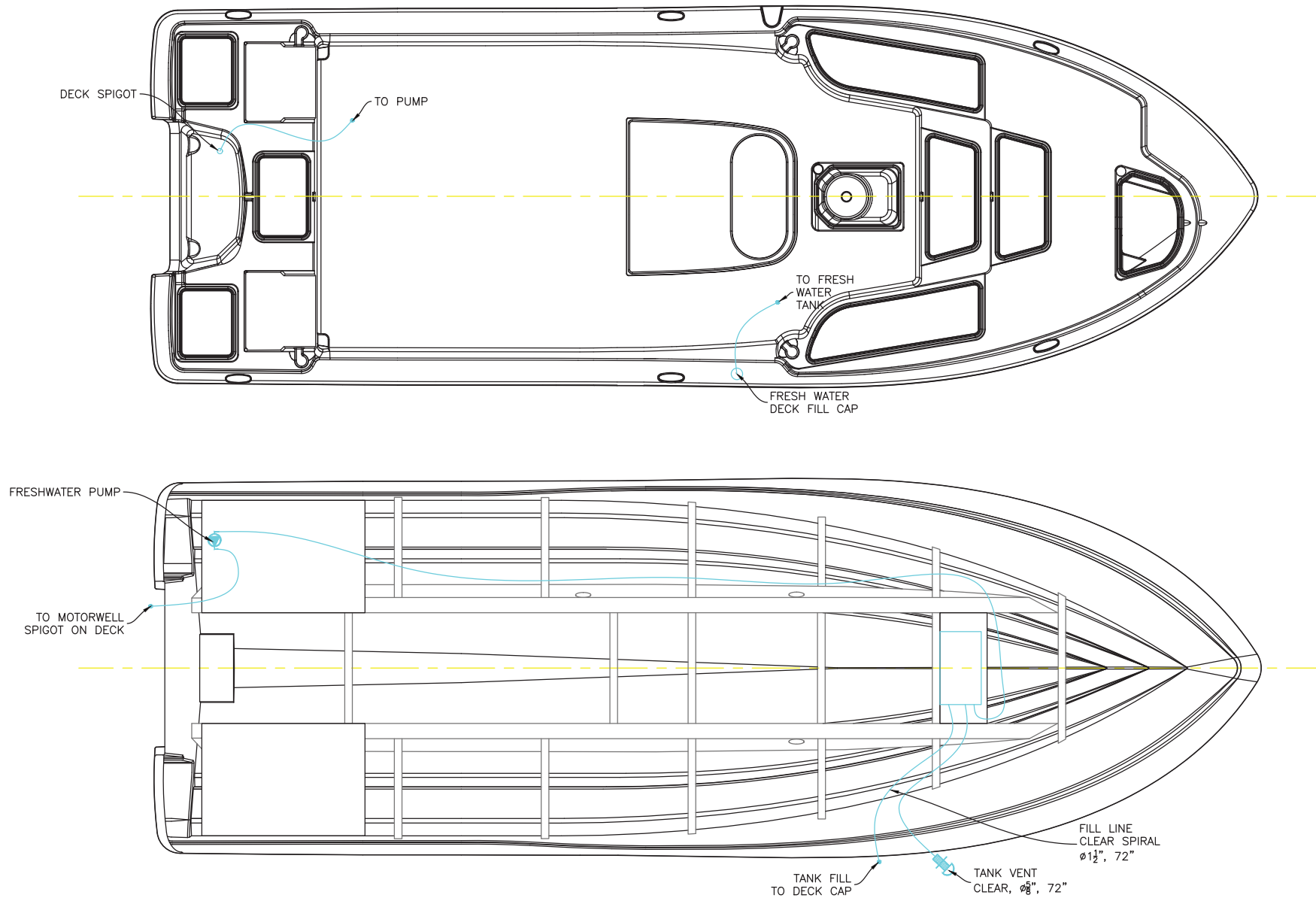

RAW WATER SYSTEM

$\phi\frac{3}{4}$ " , 90° FITTING

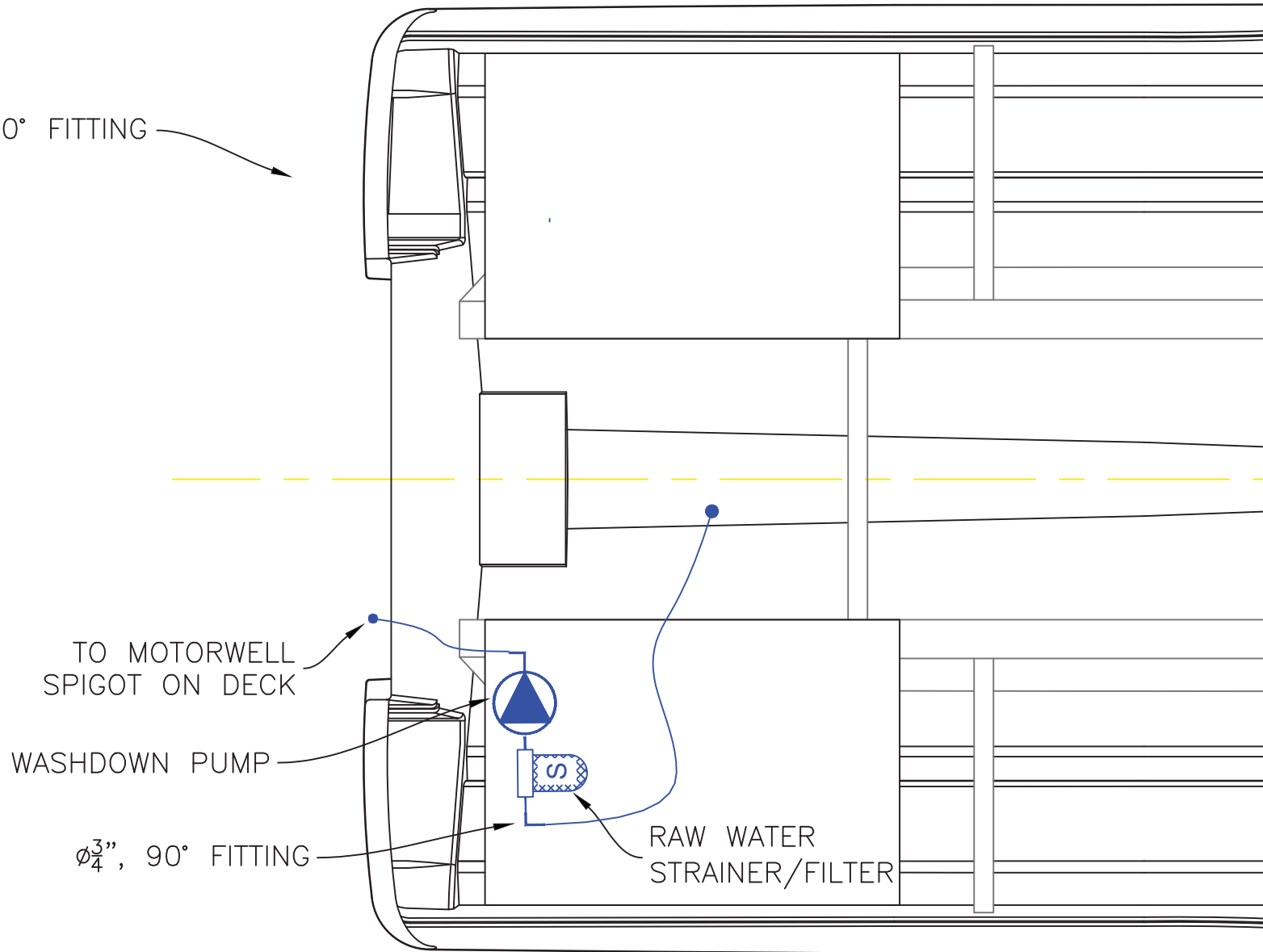

DRAINS

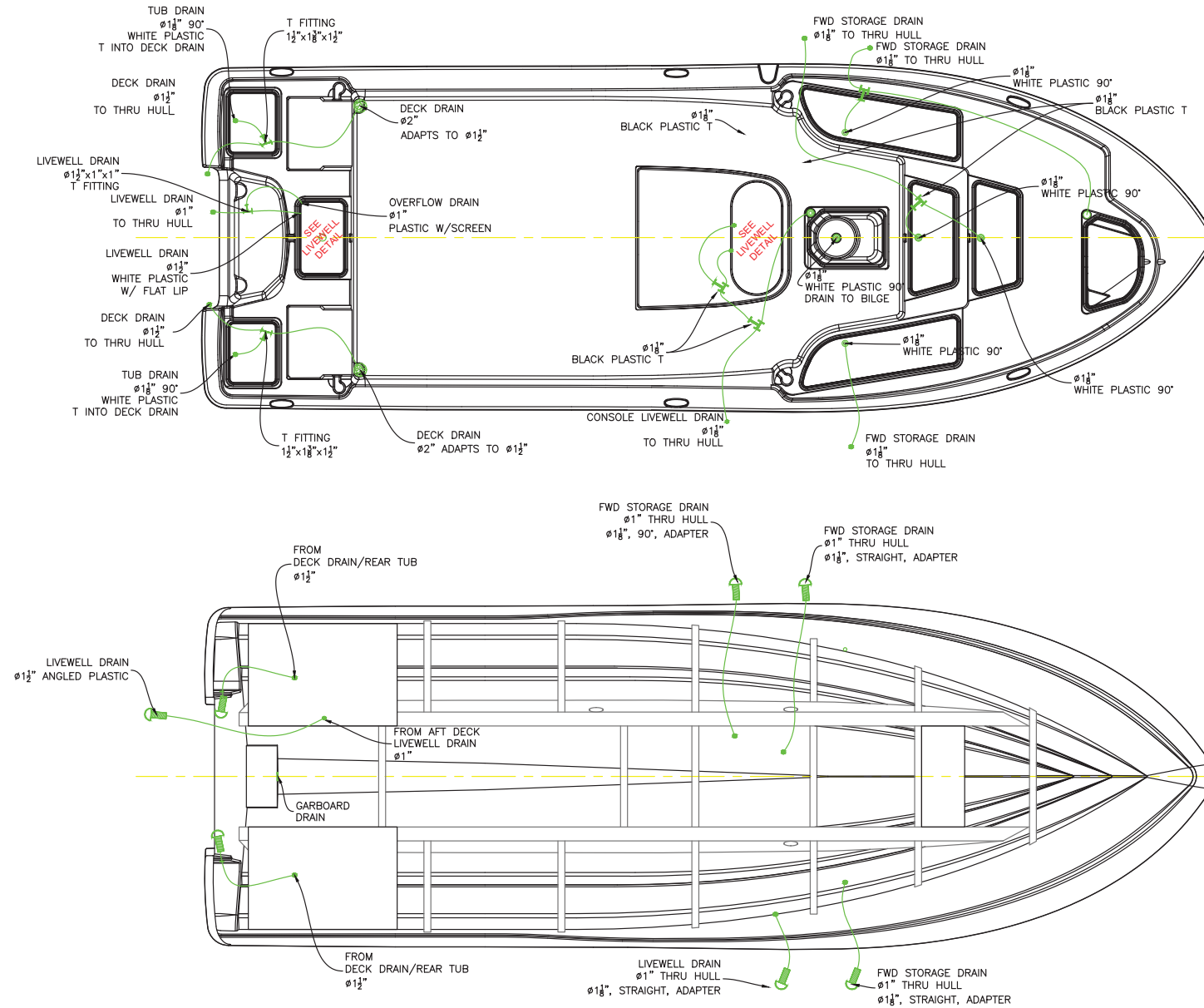

DRAINS (CONTINUED)

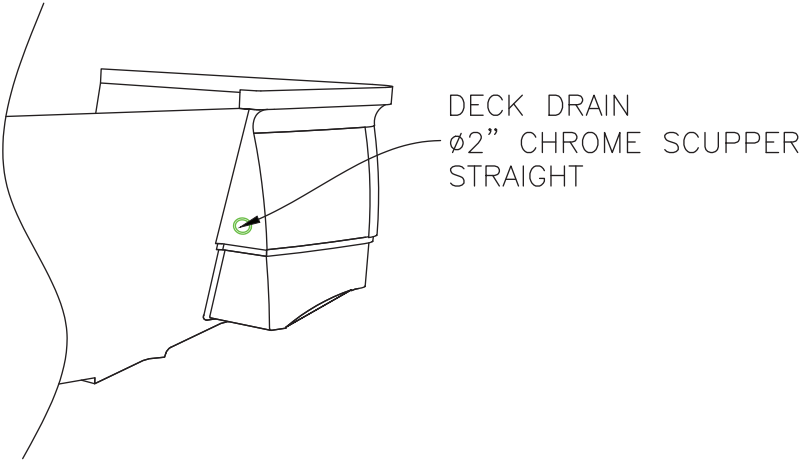
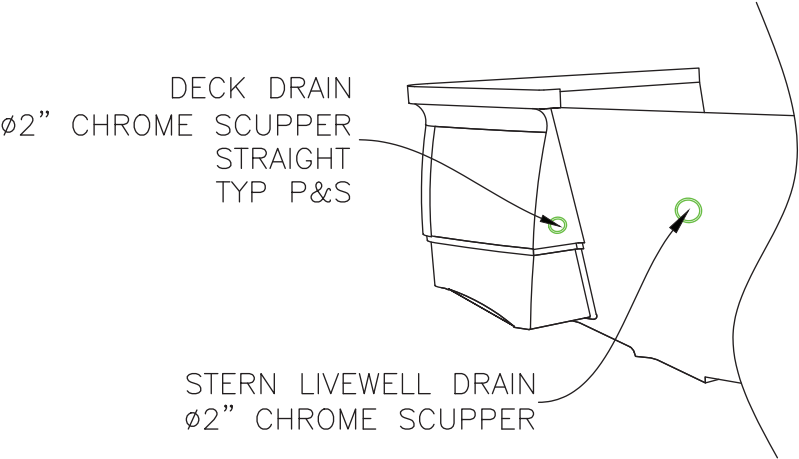

LIVEWELL SYSTEM

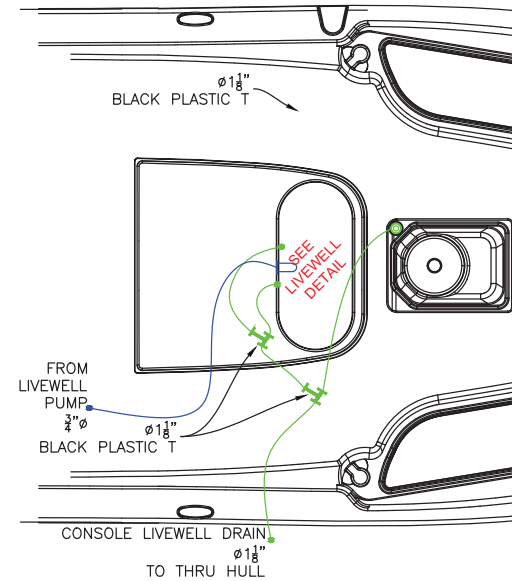
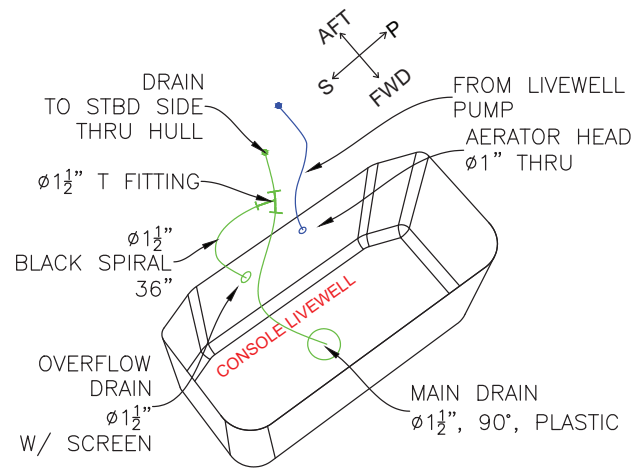

LIVEWELL DETAILS

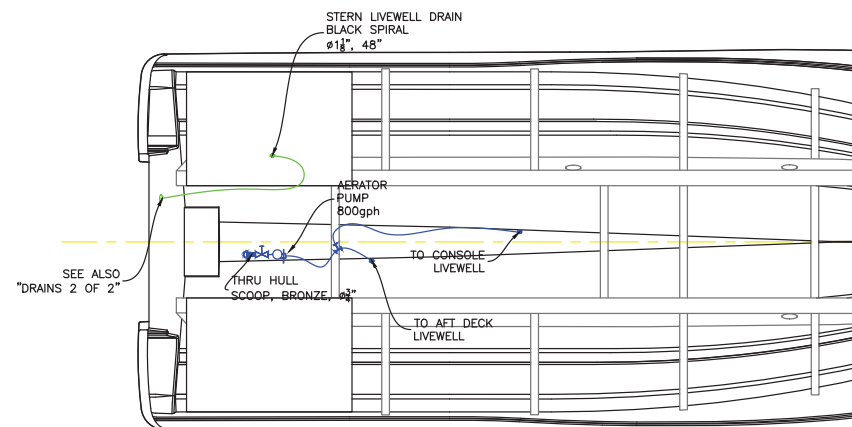
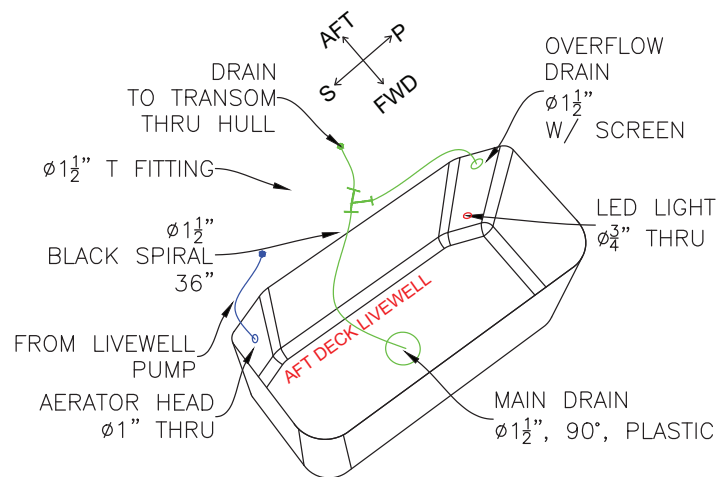

MAIN ACC HARNESS BAY FOX 231-251

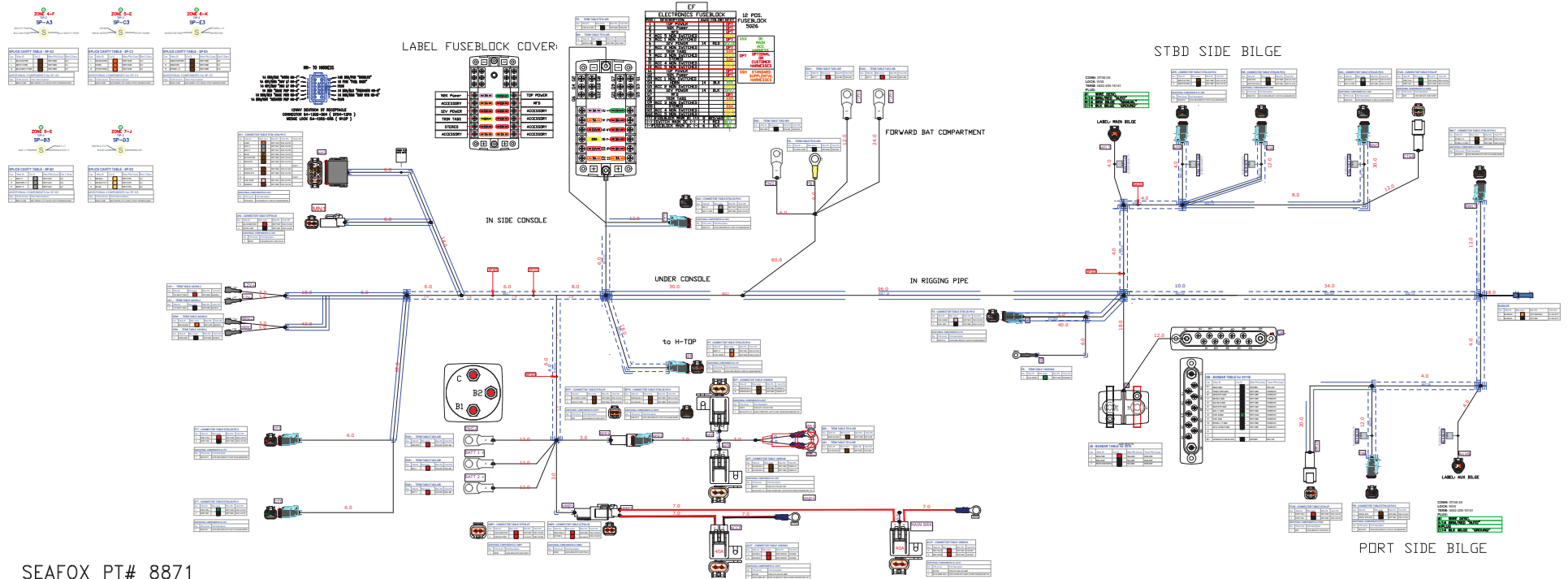

SEAFOX PT# 8871

SWITCH PANEL

MAIN SWITCH PANEL

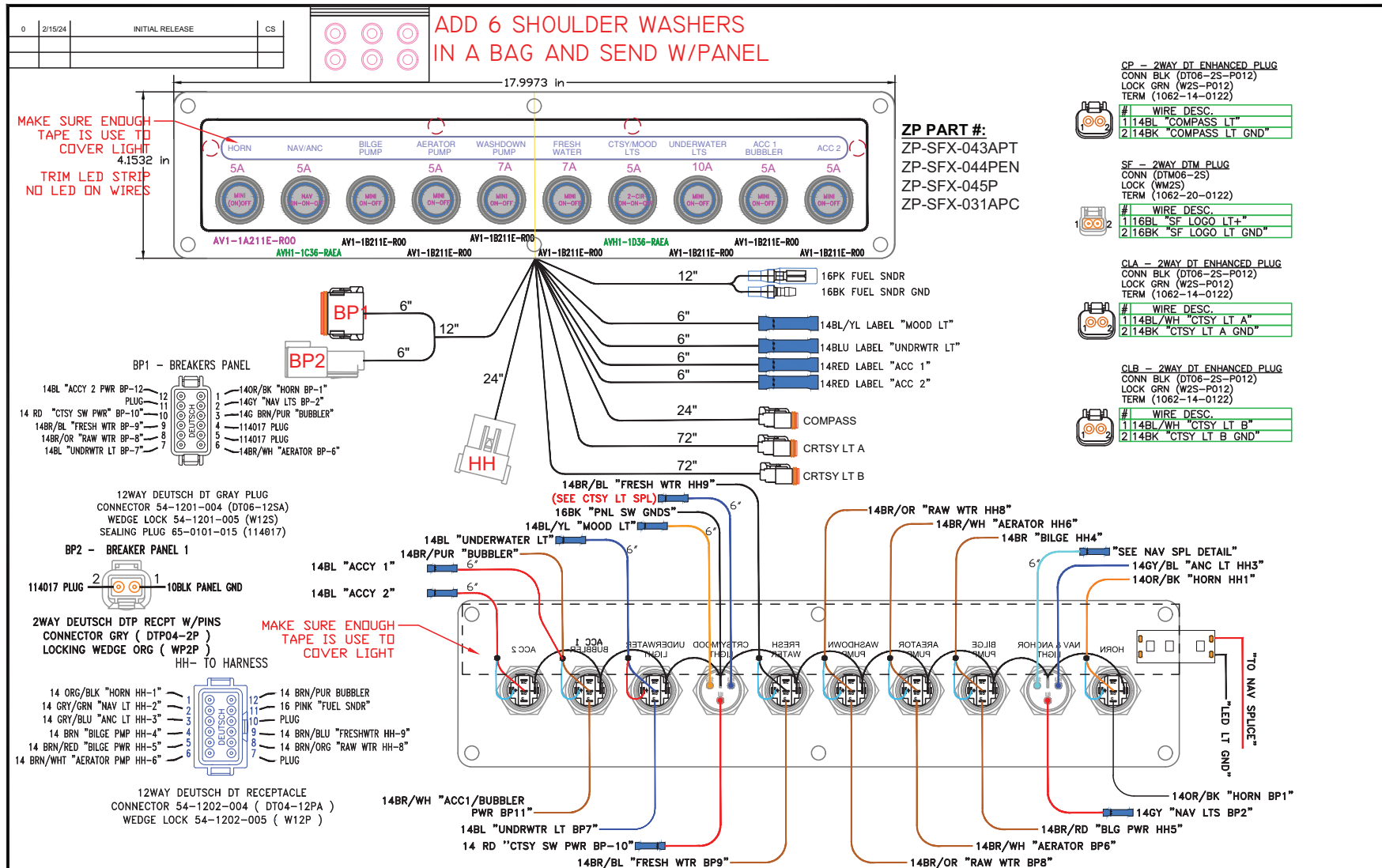

BREAKER PANEL

BREAKER PANEL

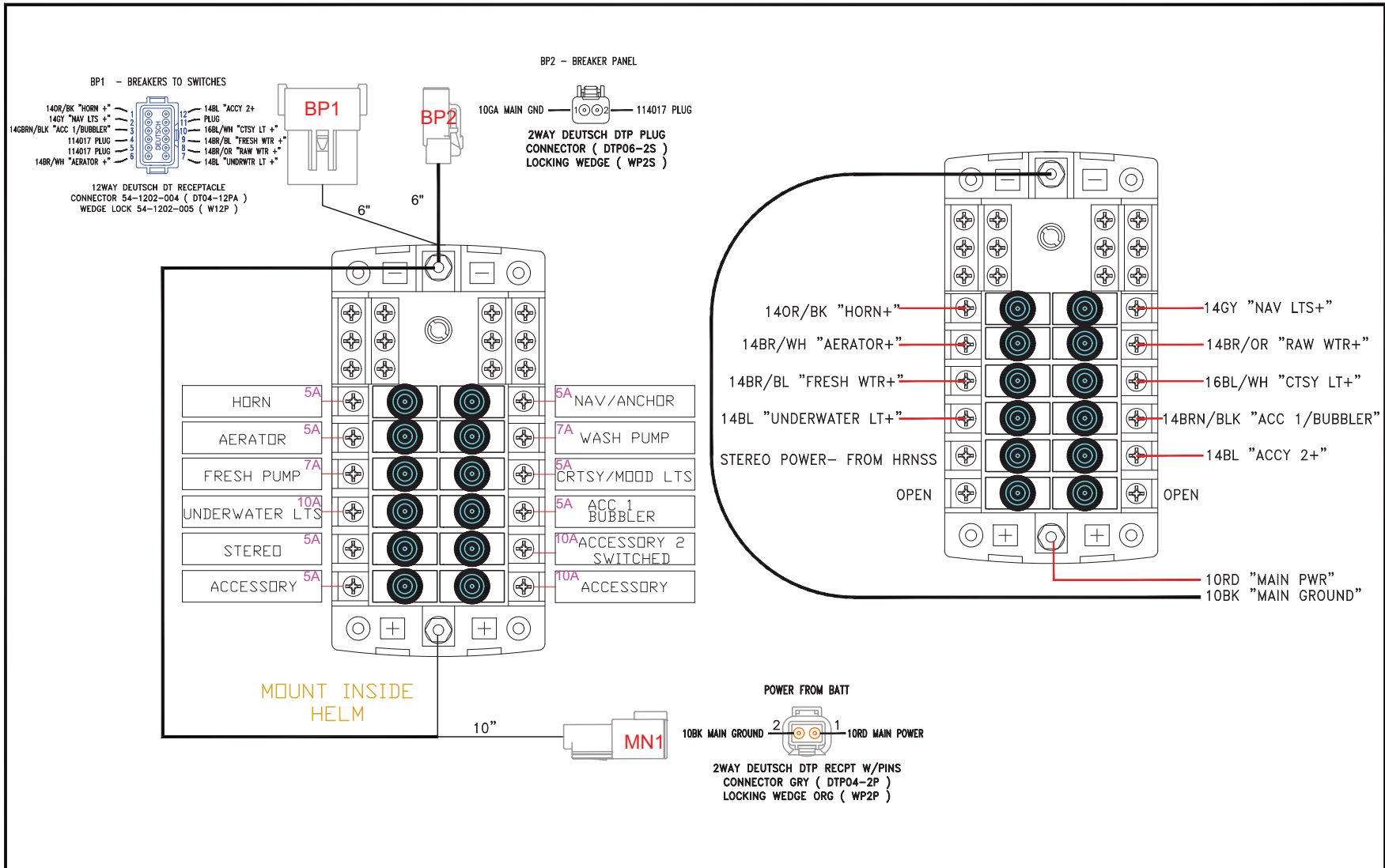

DECK HARNESS

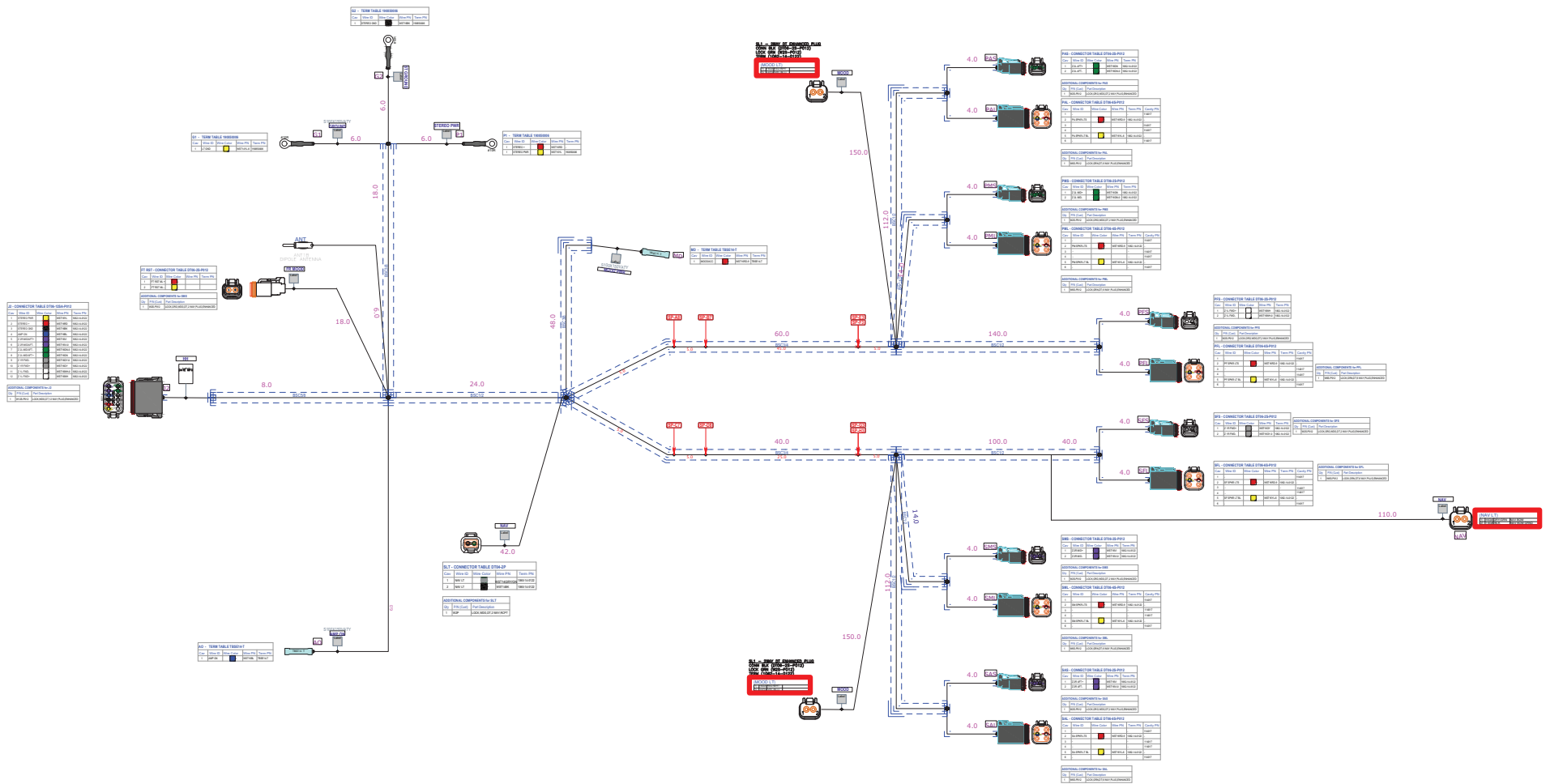

6 SPEAKER STEREO, NAV, MOOD LIGHT HARNESS

HARDTOP OPTION

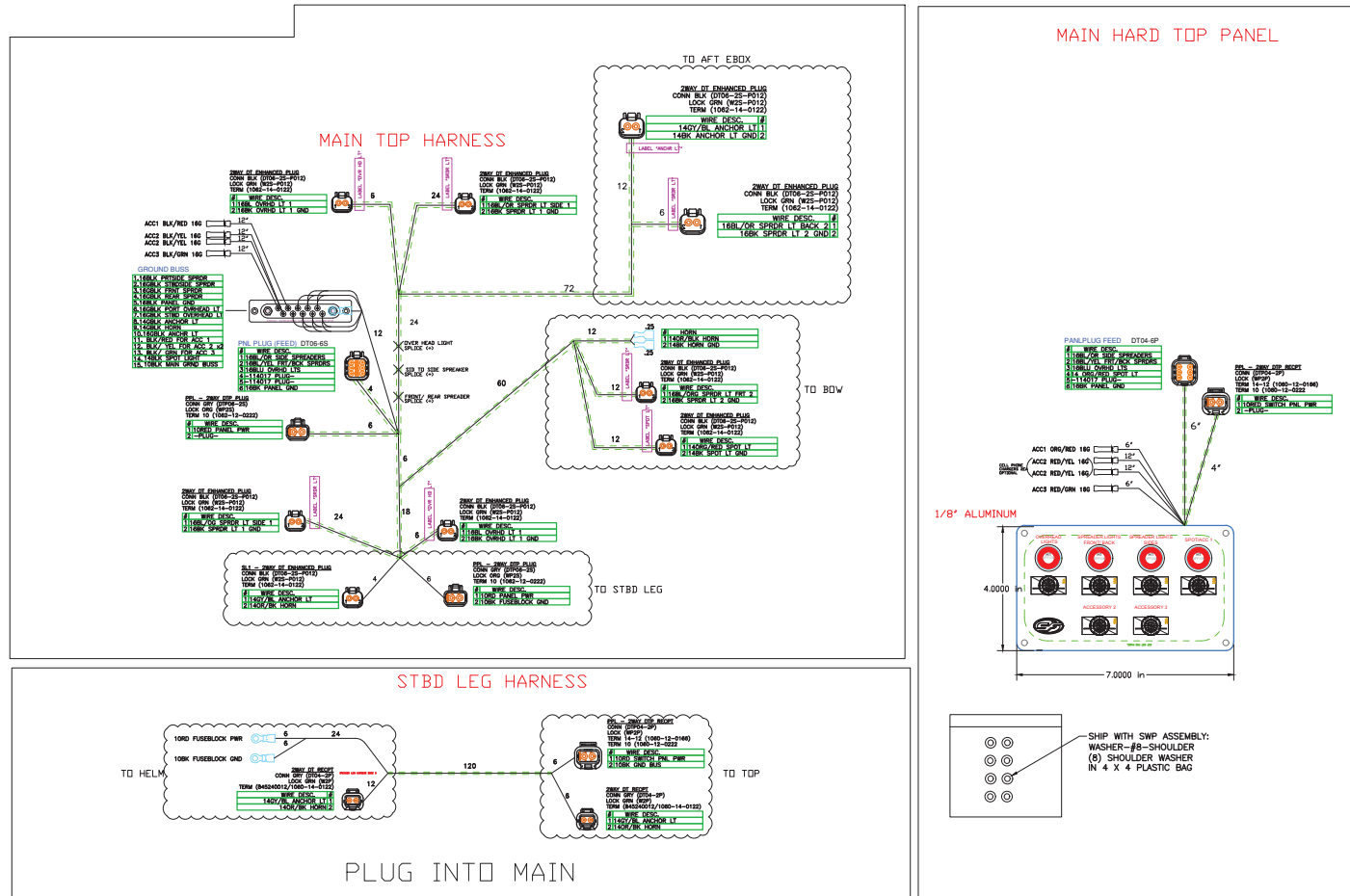

SEAFOX PT# 7939

UNDERWATER LIGHTS HARNESS

UNDER WATER LIGHT OPTION

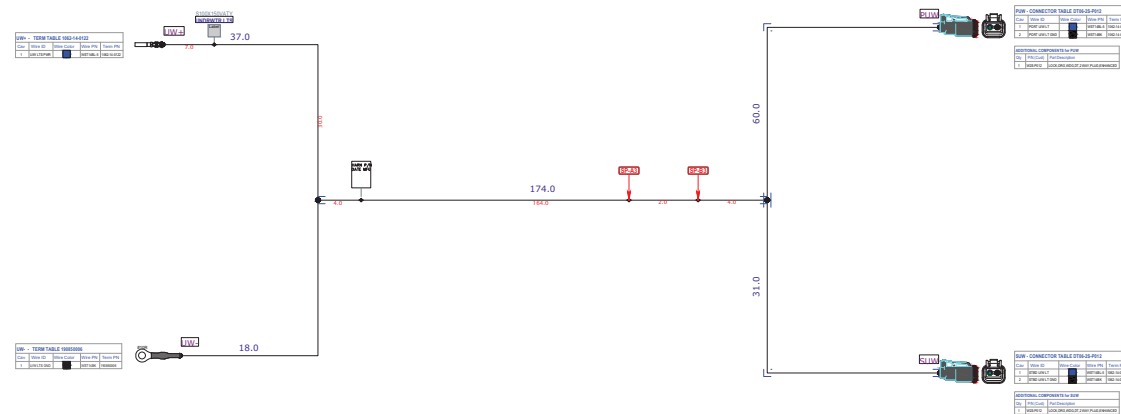

SEAFOX PT# 7930

TROLLING MOTOR HARNESS

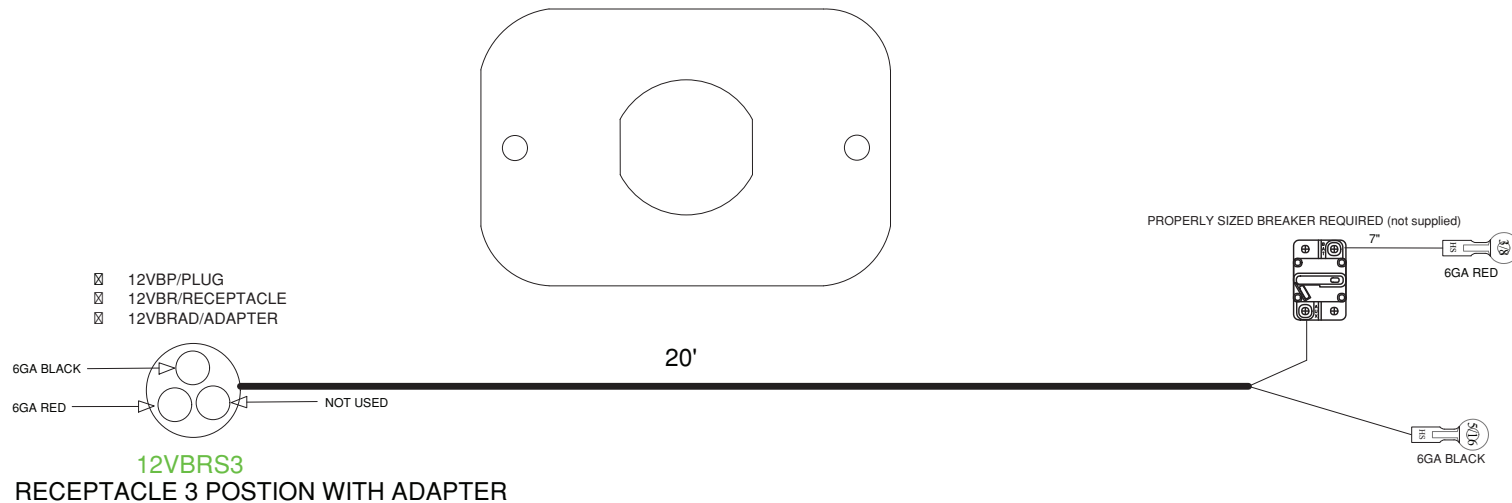

SF# 8830

BATTERY WIRING

— (+) 12V DC
— (-) 12V DC Ground

NOTE: UNDER NORMAL OPERATING CONDITIONS MAIN BATTERY SWITCH IS ON 1. IN LOW VOLTAGE SITUATIONS REFER TO THE BELOW EMERGENCY ENGINE START DIRECTIONS.

EMERGENCY ENGINE START

TO USE BATTERY #2 FOR EMERGENCY CRANKING PLACE SWITCH TO BOTH, OR TO 2 IF A SHORT IN THE MAIN BATTERY IS SUSPECTED,

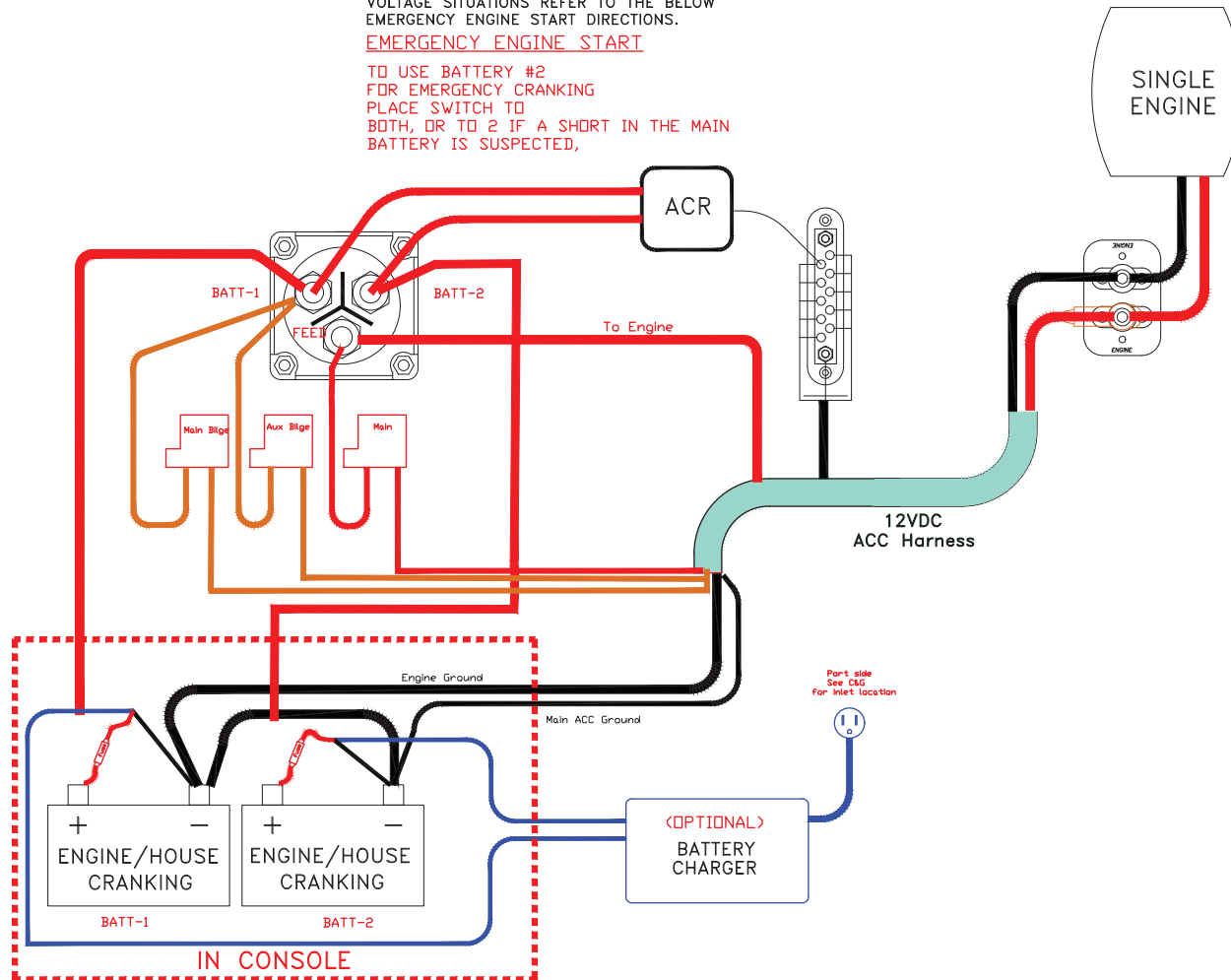

BATTERY WIRING

This Page Intentionally Left Blank

SEA FOX

BOAT WORKS

Sea Fox Boat Company, Inc.
2550 Highway 52
Moncks Corner, SC 29461-5024

Telephone: 843-761-6090
www.seafoxboats.com

Ken Cook Co.
Printed in U.S.A.
Rev 0325