

248C



Owner's Manual Supplement

www.seafoxboats.com

SEA FOX BOAT'S DISCLAIMER

The following Owner's Manual is provided for information and educational purposes only and is not intended to offer or provide legal advice or create a contractual relationship between Sea Fox Boat Company and the owner of any Sea Fox brand vessel. Please beware that as a vessel owner you have non-delegable responsibilities regarding the safety, maintenance, fitness, and operation of your vessel and the extent of such responsibilities is ultimately determined by Federal law and regulations, the general maritime law of the United States, the laws and regulations of the states and territories of the United States, or the laws and regulations of the country where you operate your vessel. To fully understand your responsibilities as a vessel owner, and before operating or letting any third party operate your vessel, we recommend that you consult the services of a qualified lawyer in admiralty and maritime law.

TABLE OF CONTENTS

| | | | |
|----------------------------------------|----|-------------------------------------|----|
| Introduction | 3 | Electrical Schematics | 15 |
| Specifications | 3 | Main Harness | 15 |
| Designated Occupant Seating | 4 | Switch Panel | 16 |
| Safety Decals | 5 | Breaker Panel | 17 |
| Plumbing Schematics | 7 | Deck Harness | 18 |
| Commander Fuel System | 7 | Hardtop Harness | 19 |
| Commander Bilge System | 8 | Underwater Lights Harness | 20 |
| Commander Fresh Water System | 9 | Windlass Cables Harness | 21 |
| Commander Raw Water System | 10 | Windlass Deck Harness | 22 |
| Commander Hull Drains | 11 | Windlass Switch Panel | 23 |
| Commander Deck Drains | 12 | Windlass Deck Bow Panel | 24 |
| Commander Livewell System | 13 | Trolling Motor Harness | 25 |
| Commander Waste System | 14 | Electric Head Harness | 26 |
| | | Battery Wiring | 27 |

This Page Intentionally Left Blank

INTRODUCTION

Congratulations and Welcome Aboard! With so many boat brands to choose from, we want to congratulate you on your decision to choose Sea Fox Boats. For more than 24 years, Sea Fox offers the finest hand-crafted saltwater boats carefully balanced with the build-quality, features, styling and performance for the fairest price. Our passion for boating is evident in every model we make and we appreciate that you've noticed the Sea Fox difference.

We share your love for the moments spent on the water with friends and family, which is why every Sea Fox boat offers a unique blend of fishing/family options, technologies and innovative features. Your choice of a Sea Fox affirms that you have performed your research and compared the value of your model with the competition.

Whether you are new to the boating lifestyle or an old salt, we ask that **you and all other operators** read the owner's manual, this supplement, and all other literature provided with the boat **before** operating the boat or any equipment. We also recommend that all operators enroll in a boating safety course available online - see References and Contact Information in this section for education resources online.

This supplement contains model-specific information not included with the owner's manual. This manual is not intended to be a replacement for specific product literature provided by engine, accessory or other major equipment manufacturers, but rather to supplement that information.

Because of our philosophy of continuous product improvement, this manual serves as a general guide only, so the specifications and illustrations used may not match the equipment on your boat and are intended only as general reference views.

We welcome you to the Sea Fox family and wish you many years of boating enjoyment!

SPECIFICATIONS

| | |
|------------------------------------------|--------------------|
| Max. Weight Capacity | 2500 lbs (1134 kg) |
| Persons | 10 |
| Persons Weight | 1500 lbs (680 kg) |
| Max. HP | 300 hp (224 kw) |
| L.O. A. | 24' 4" (7.41 m) |
| Beam | 8' 6" (2.59 m) |
| Draft | 14 in. (0.36 m) |
| Height, Keel to Top (Light Folded) | 115 in. (2.92 m) |
| Bridge Clearance Hard Top | 99 in. (2.51 m) |
| Max. Weight Boat (w/ Fluids, Largest HP) | 5892 lbs (2673 kg) |
| Fuel Tank Capacity | 109 gal (413 L) |
| Freshwater Tank Capacity | 12 gal (45 L) |
| Holding Tank Capacity | 12 gal (45 L) |

DESIGNATED OCCUPANT SEATING

Be sure all passengers are properly seated in designated seating positions and not riding on the bow, bow pulpit, deck, gunwale or rear sun deck while underway. Passengers must use hand-holds and use caution when riding in the bow. Move to the aft passenger seats during rough water operation or if visibility is restricted.

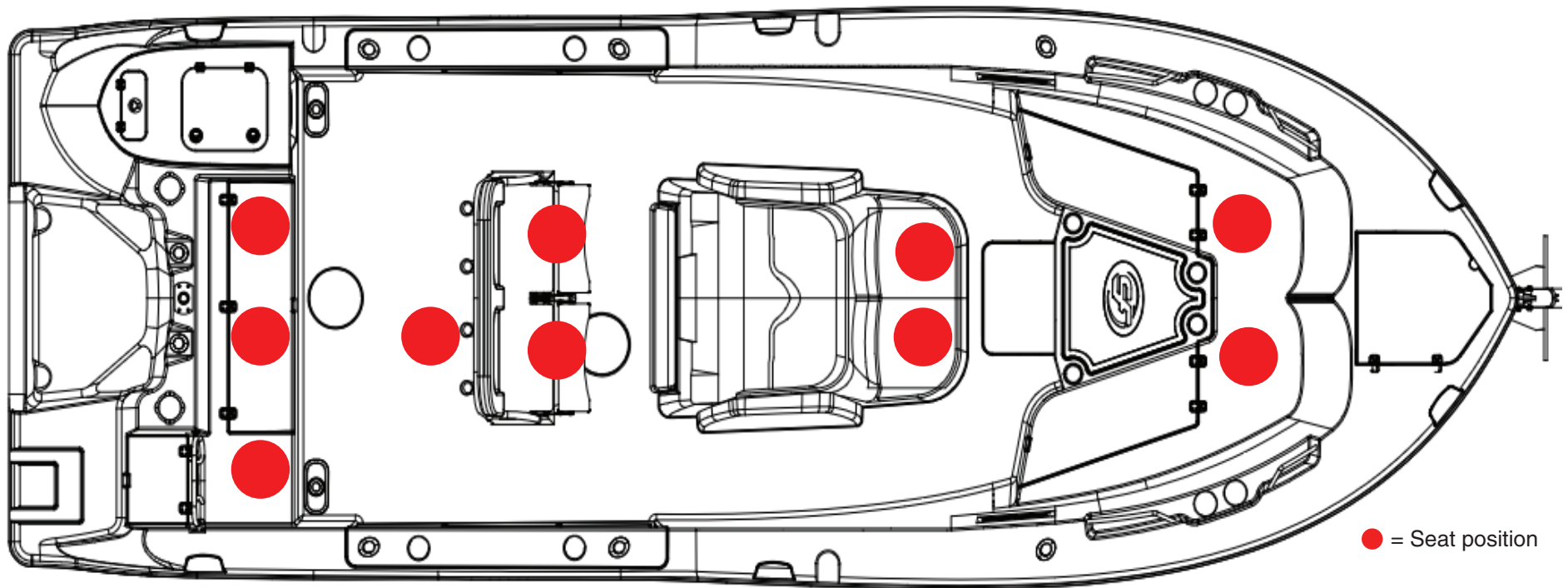

SFOX-0011

SAFETY DECALS



8



8



6



8



3

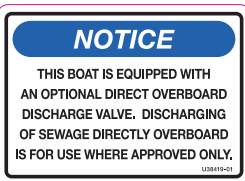

2



3

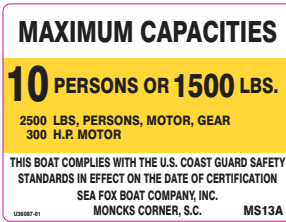

3

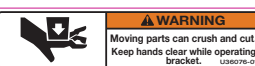

5

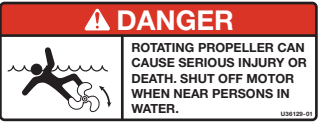

8

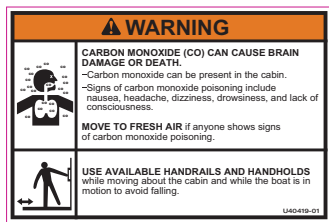

7

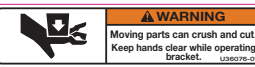

5

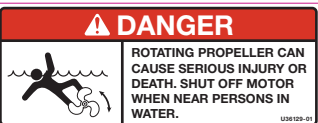

8



7

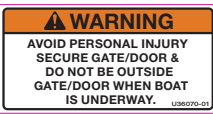

7



4



3

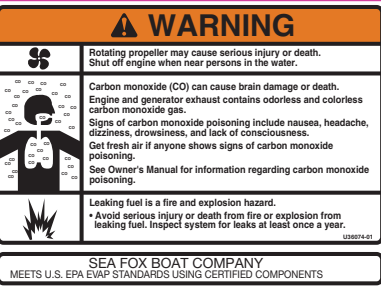

3

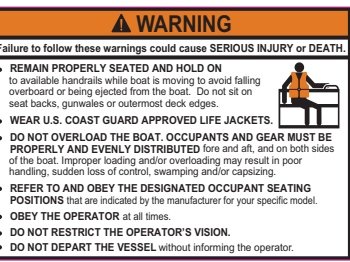

6



8



8



8



6

- 1= COCKPIT FRONT
- 2= HEAD COMPARTMENT
- 3= CONSOLE
- 4= FUEL FILL
- 5= COCKPIT MID SHIP
- 6= COCKPIT AFT
- 7= TRANSOM GATE
- 8= TRANSOM

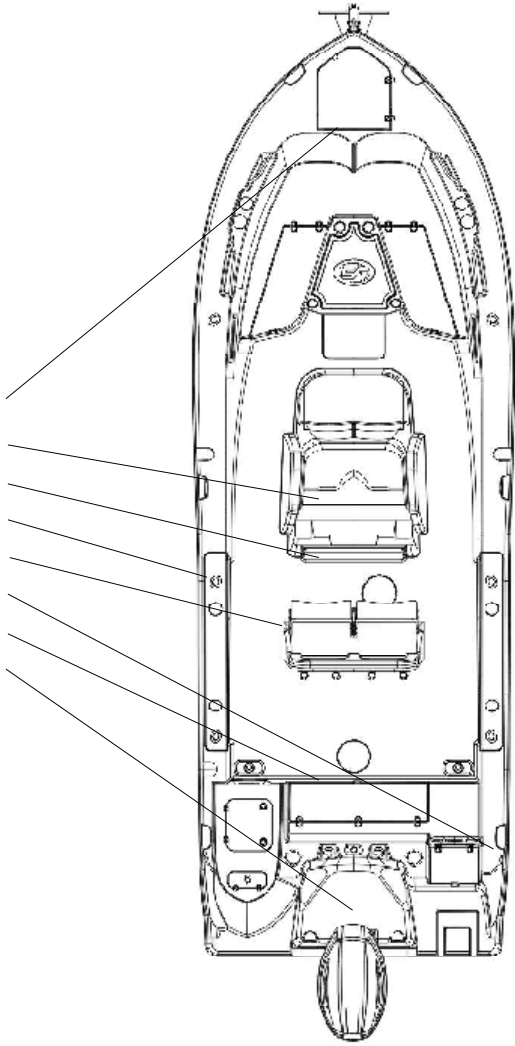

PLUMBING SCHEMATICS

COMMANDER FUEL SYSTEM

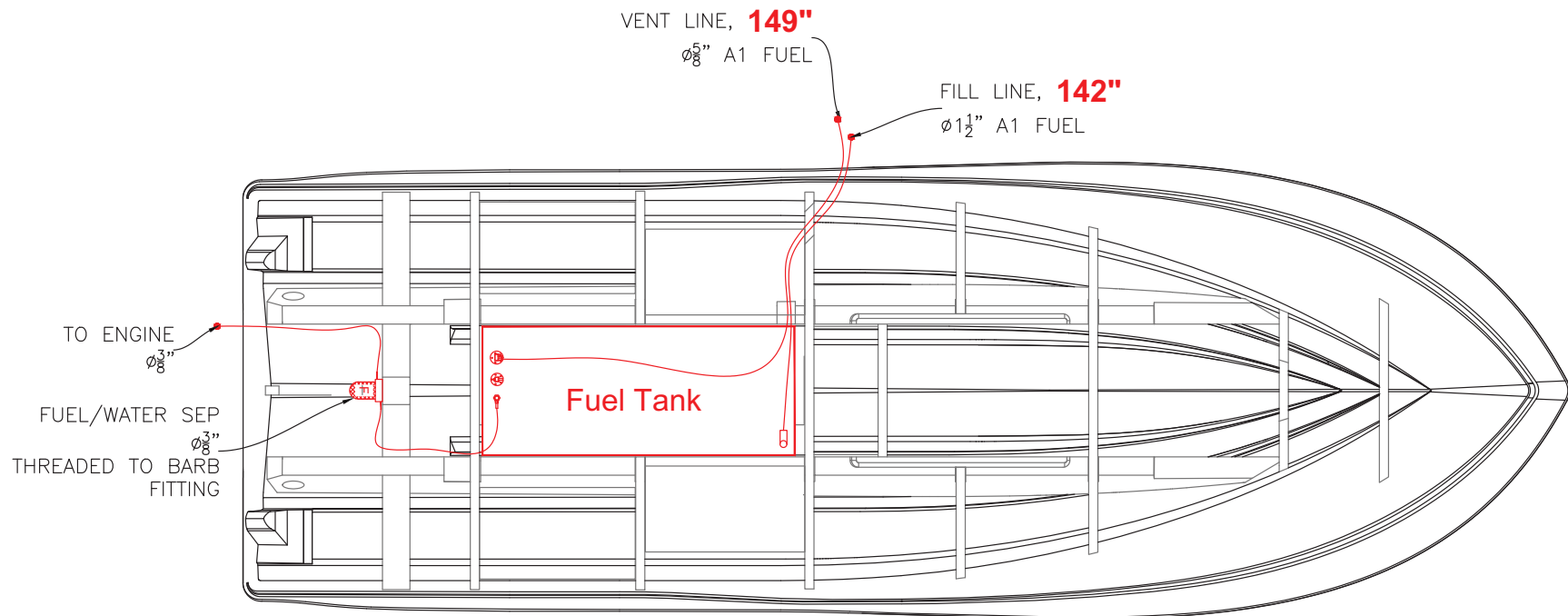
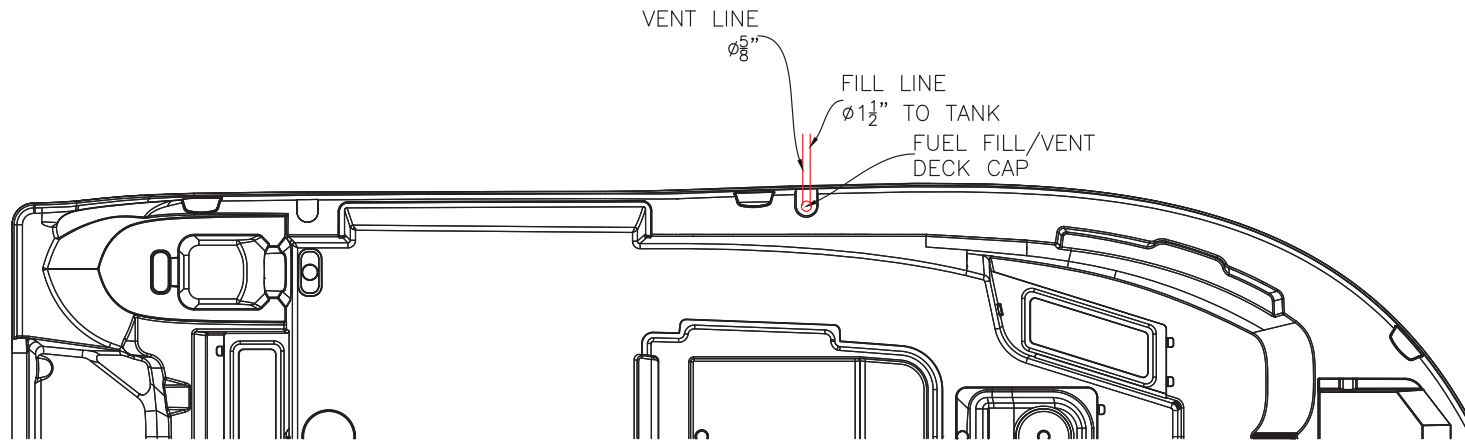

COMMANDER BILGE SYSTEM

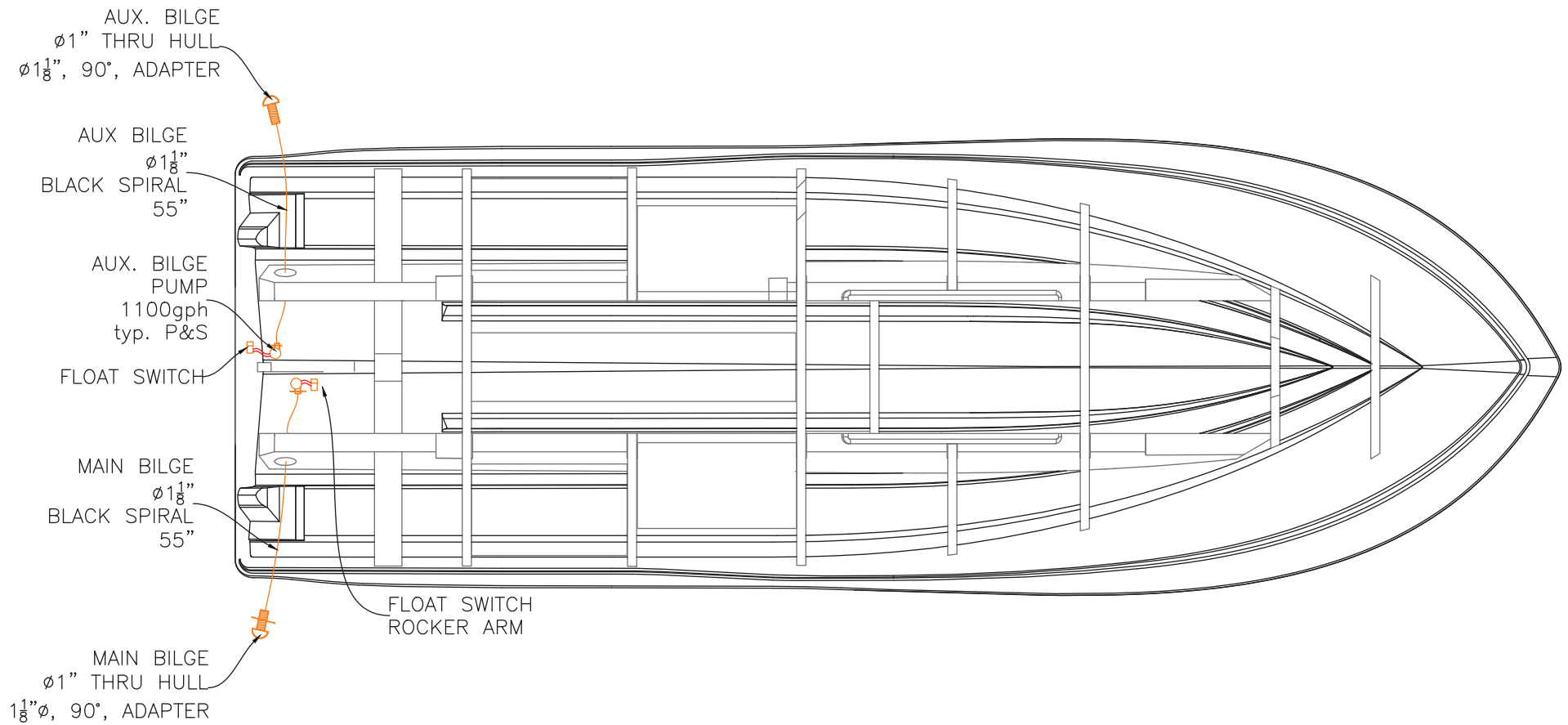

COMMANDER FRESH WATER SYSTEM

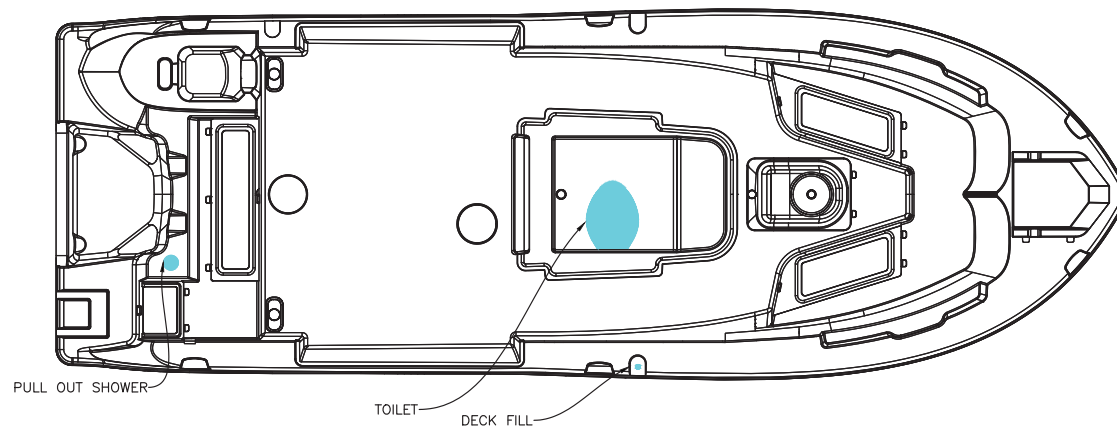
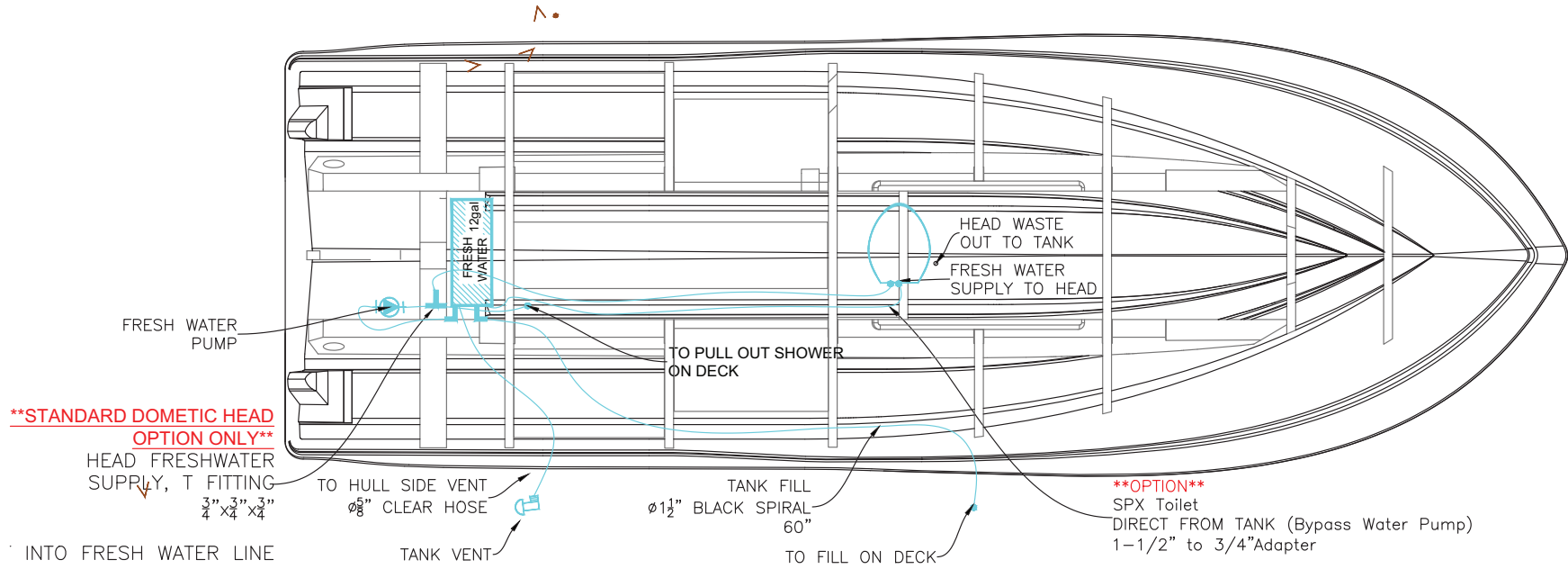

COMMANDER RAW WATER SYSTEM

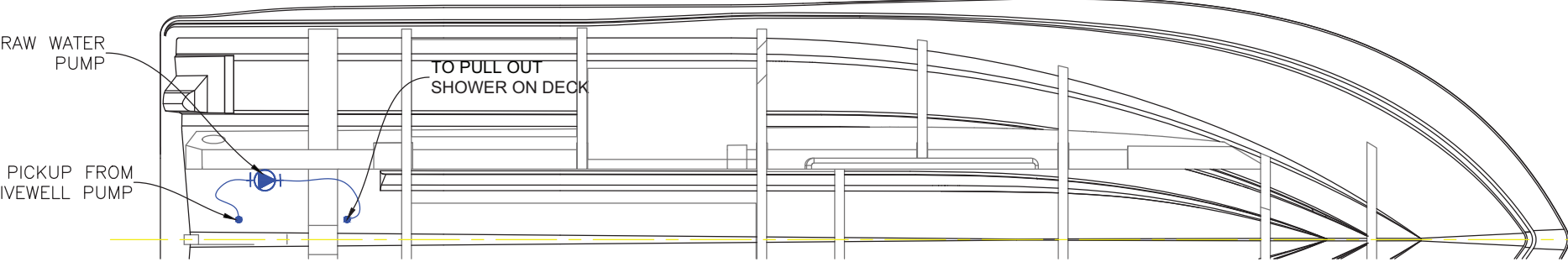
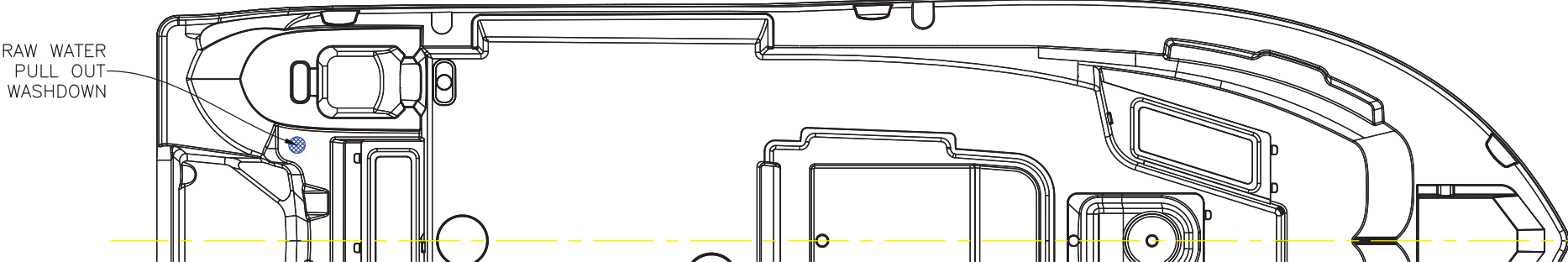

COMMANDER HULL DRAINS

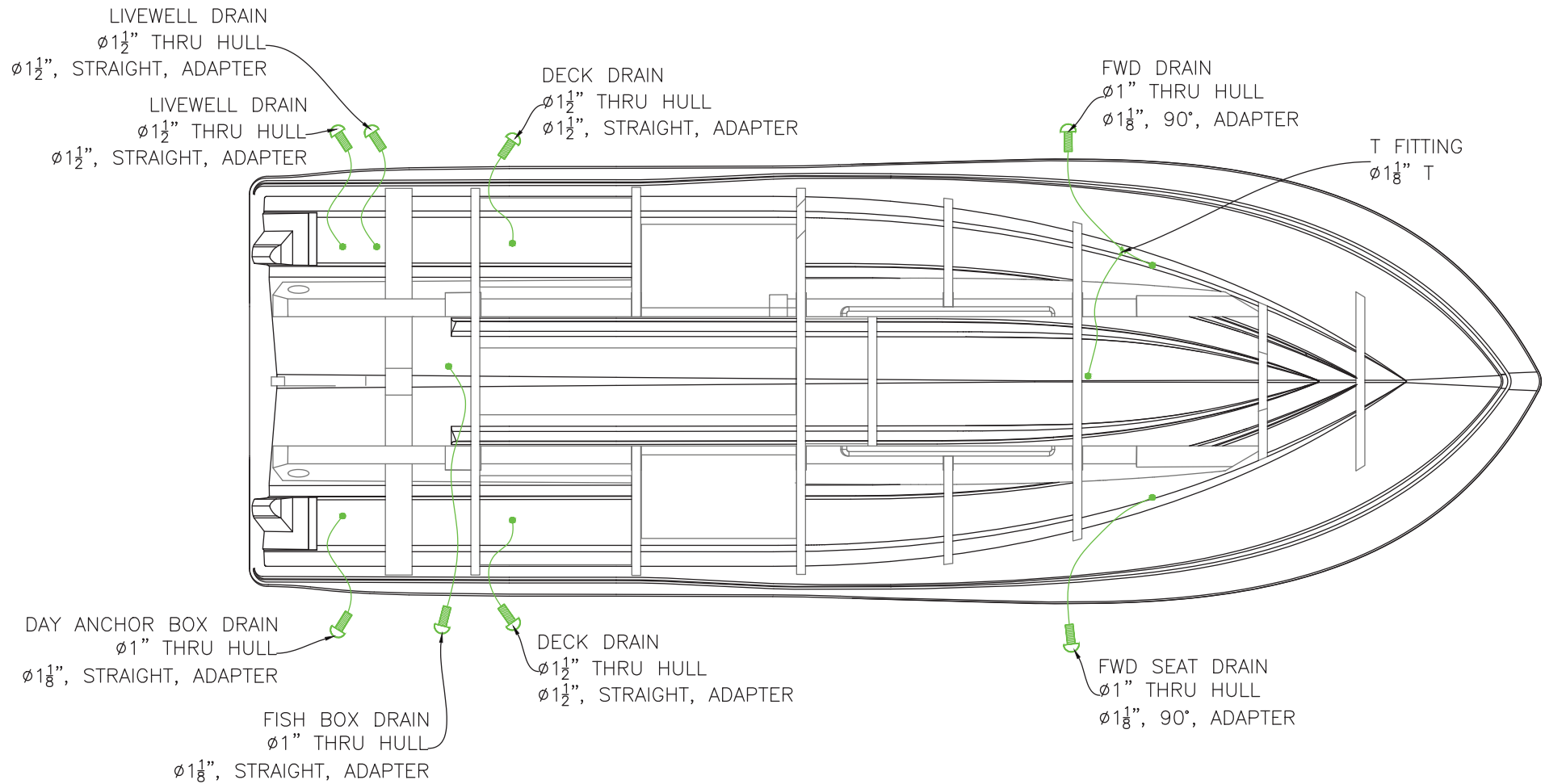

COMMANDER DECK DRAINS

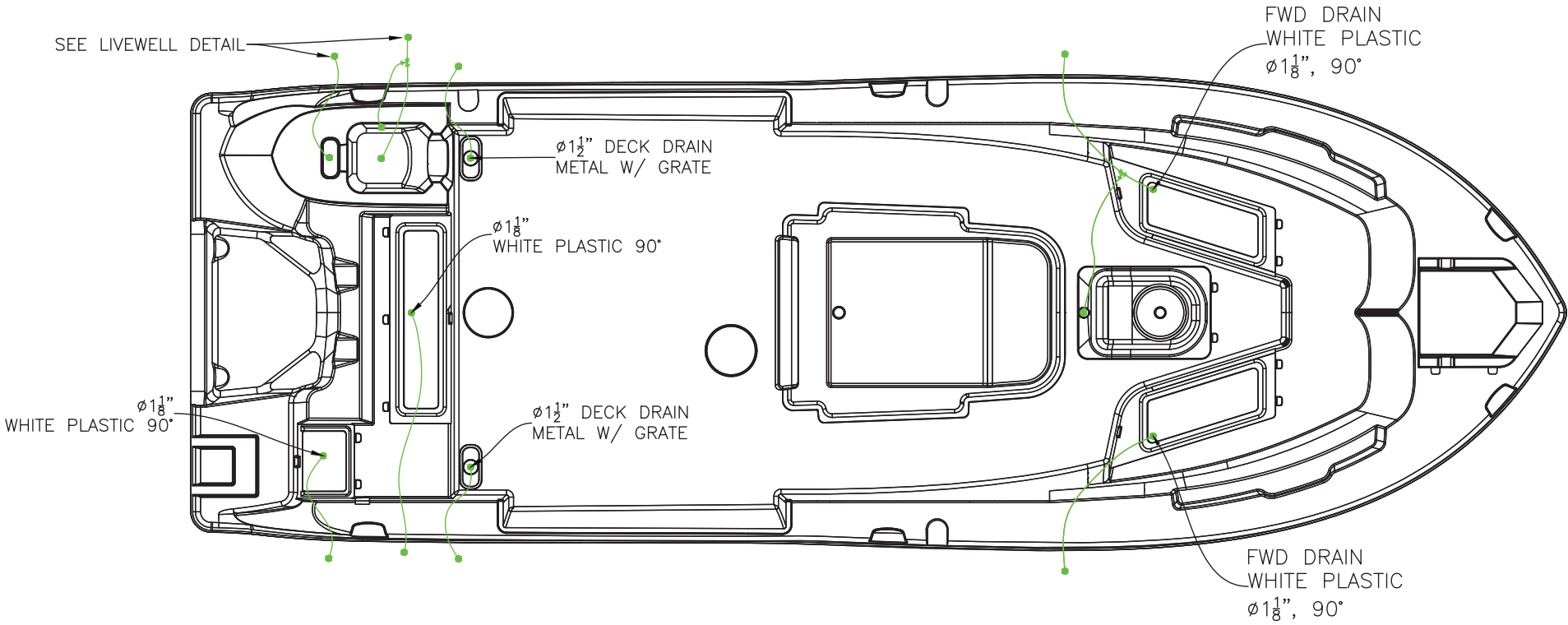

COMMANDER LIVEWELL SYSTEM

NEW LIVEWELL DRAIN
1 $\frac{1}{8}$ "-1 $\frac{1}{8}$ " GEM ADAPTER

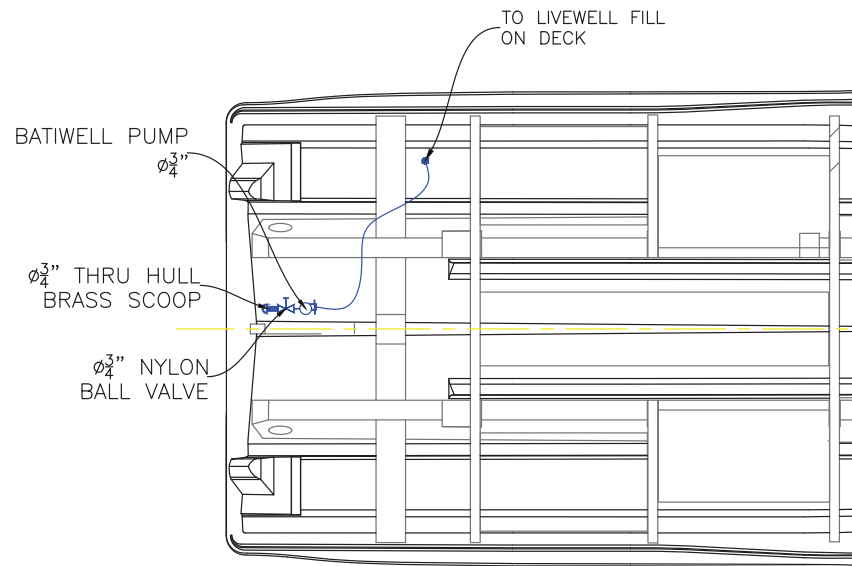
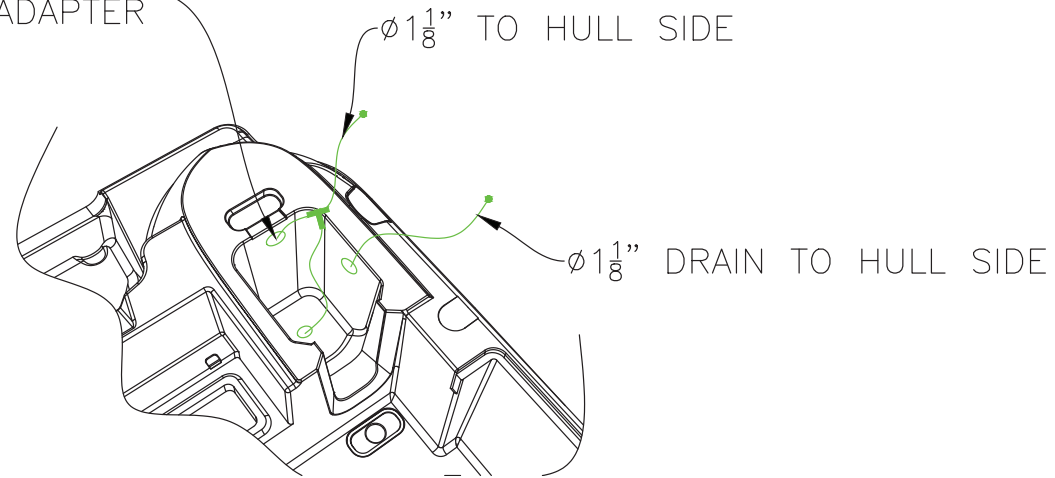

COMMANDER WASTE SYSTEM

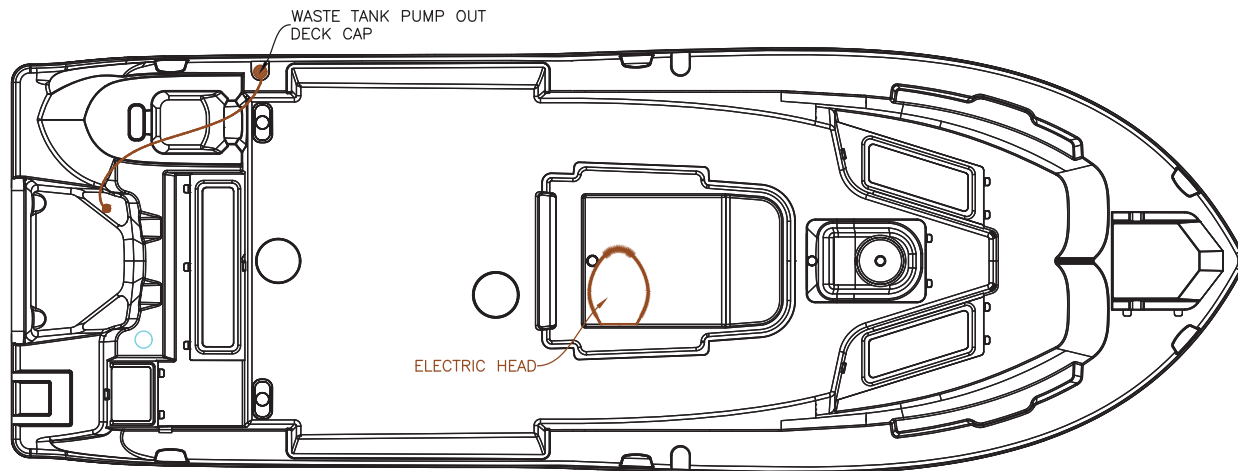
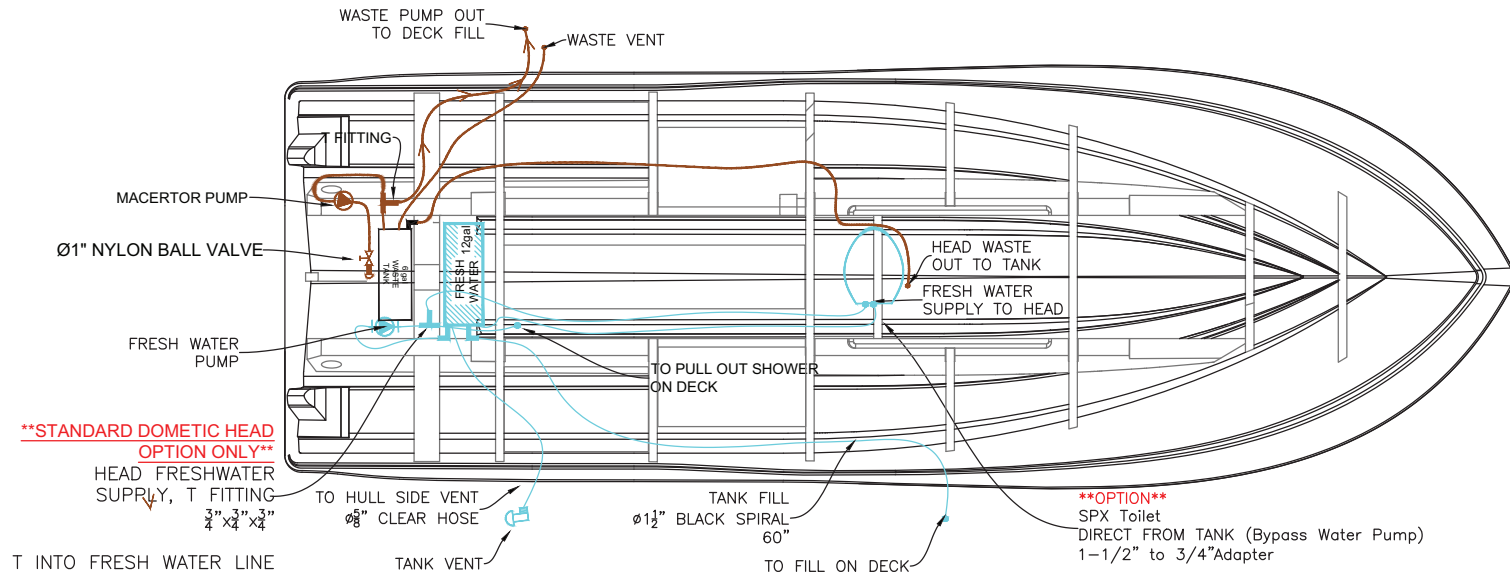

ELECTRICAL SCHEMATICS

MAIN HARNESS

MAIN HARNESS

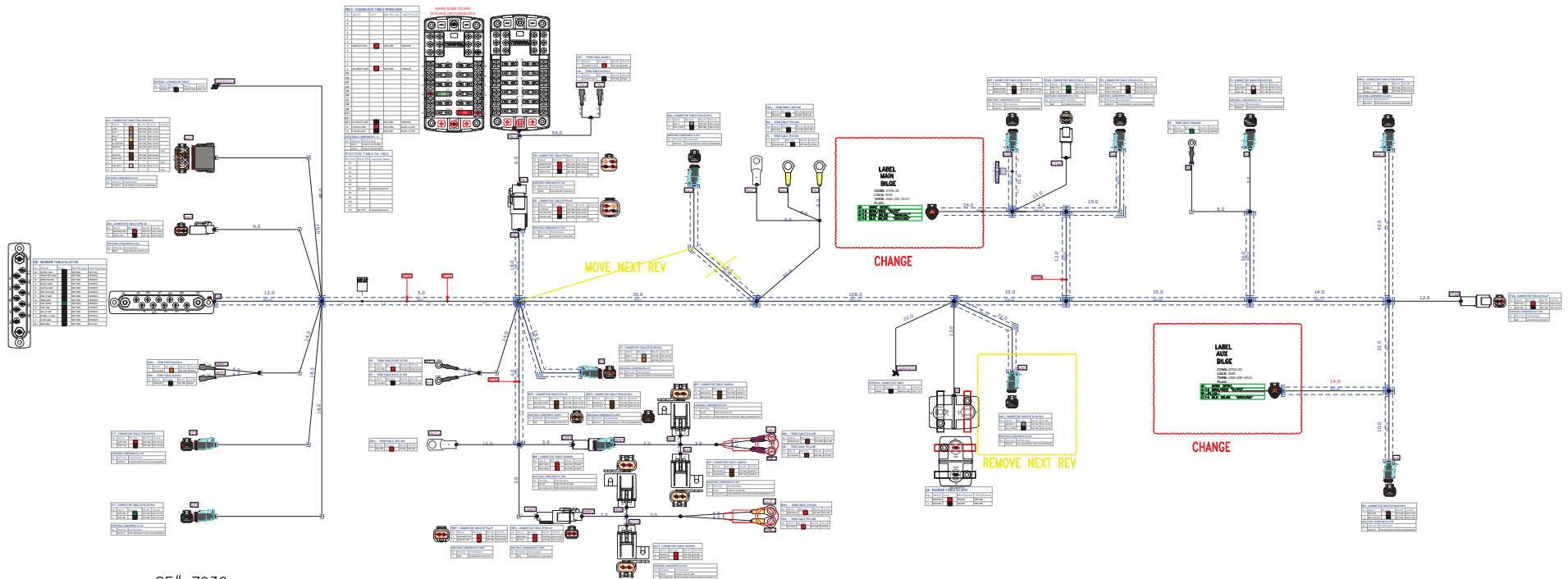

SF# 7936

SF# 7936

SWITCH PANEL

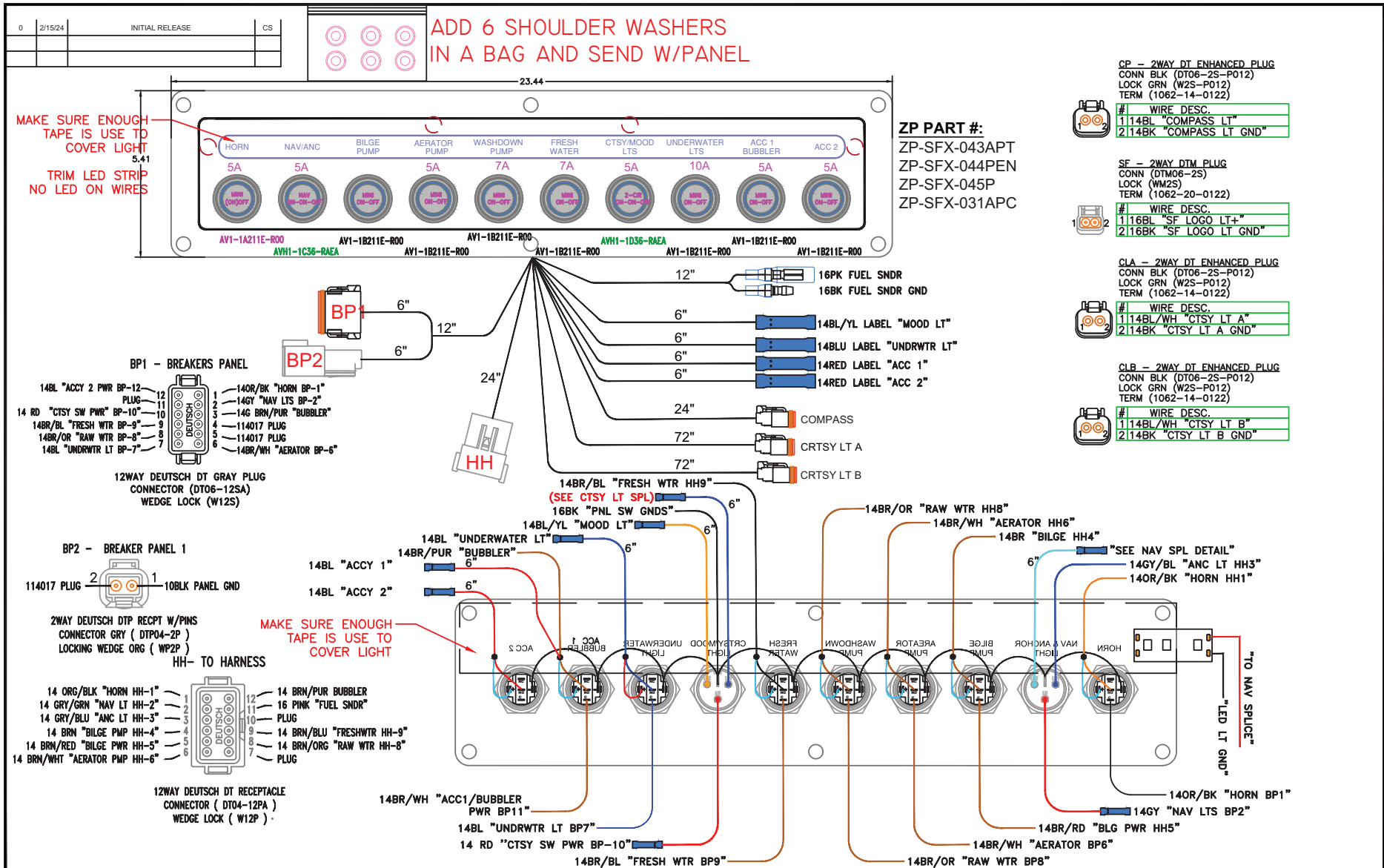

BREAKER PANEL

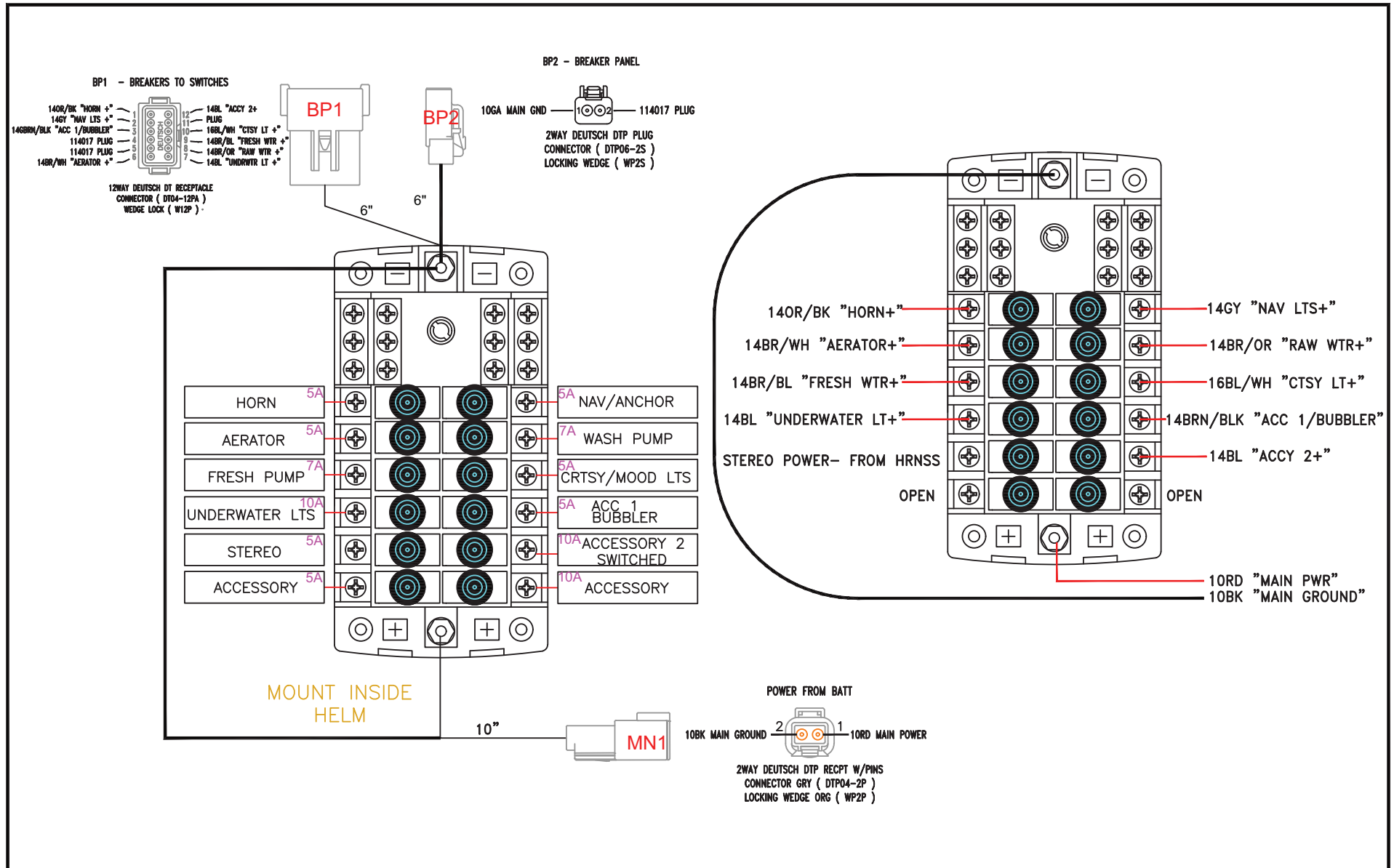

DECK HARNESS

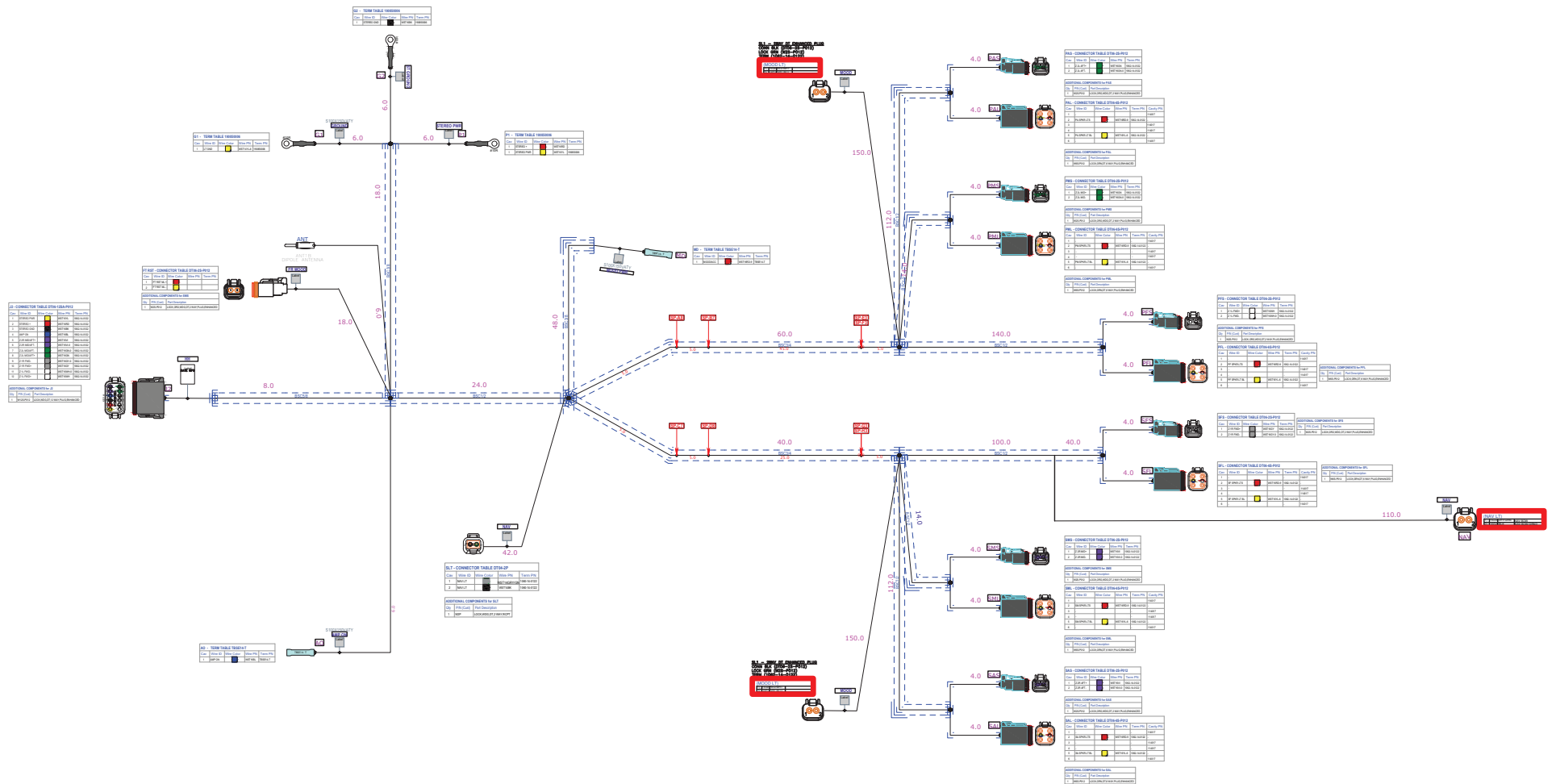

6 SPEAKER STEREO, NAV, MOOD LIGHT HARNESS

HARDTOP HARNESS

228-248 HARDTOP

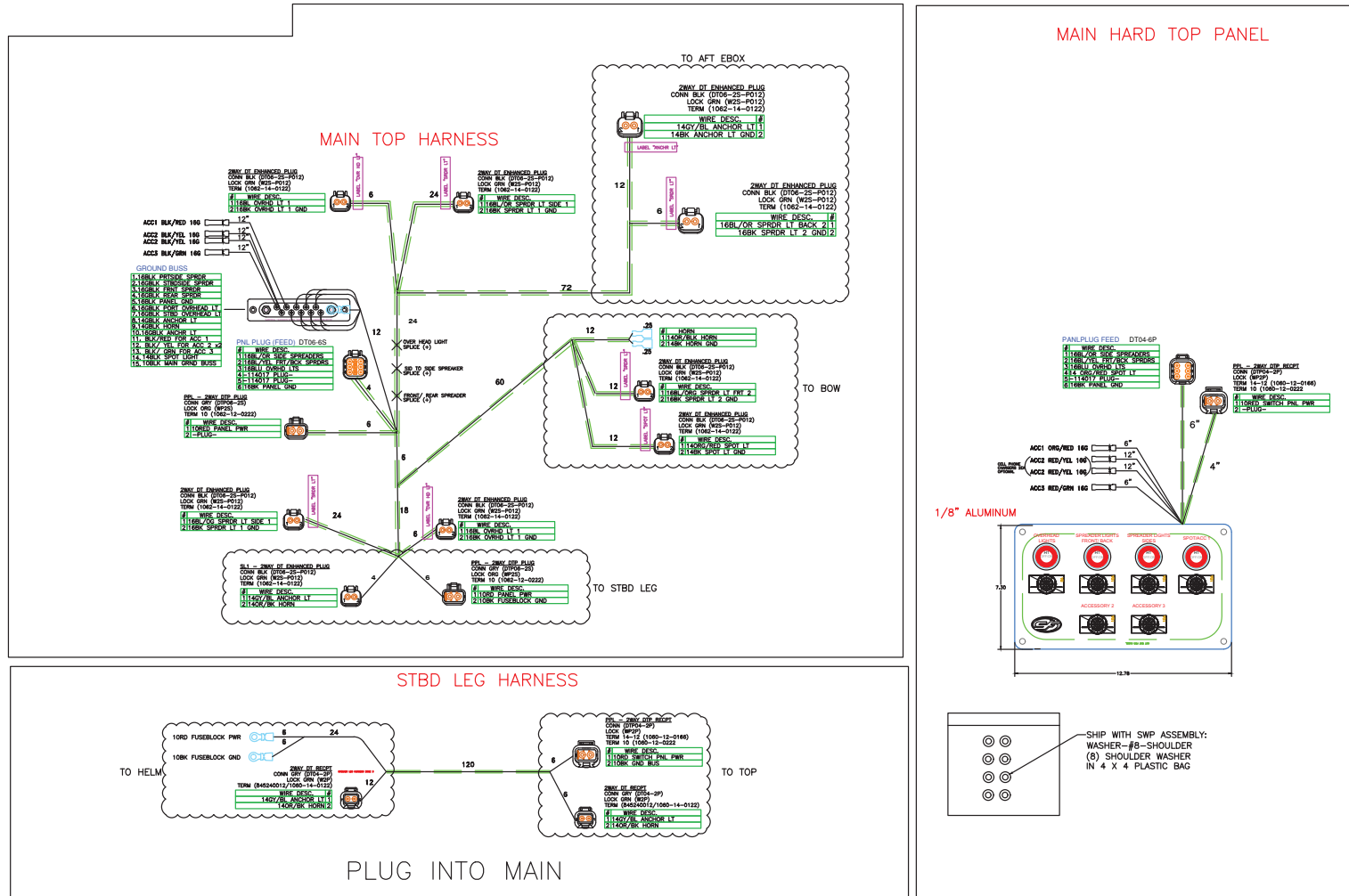

SF# 7939

UNDER WATER LIGHT OPTION

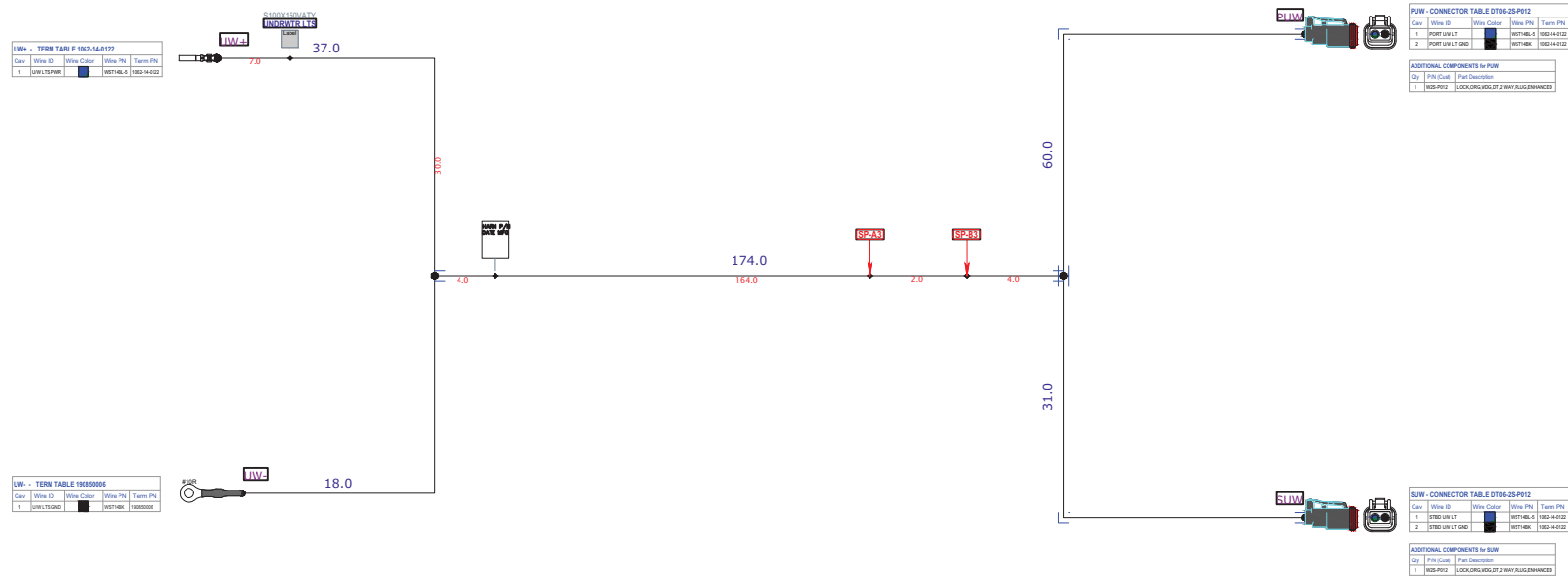

Under Water Light Harness, SF# 7930

WINDLASS CABLES HARNESS

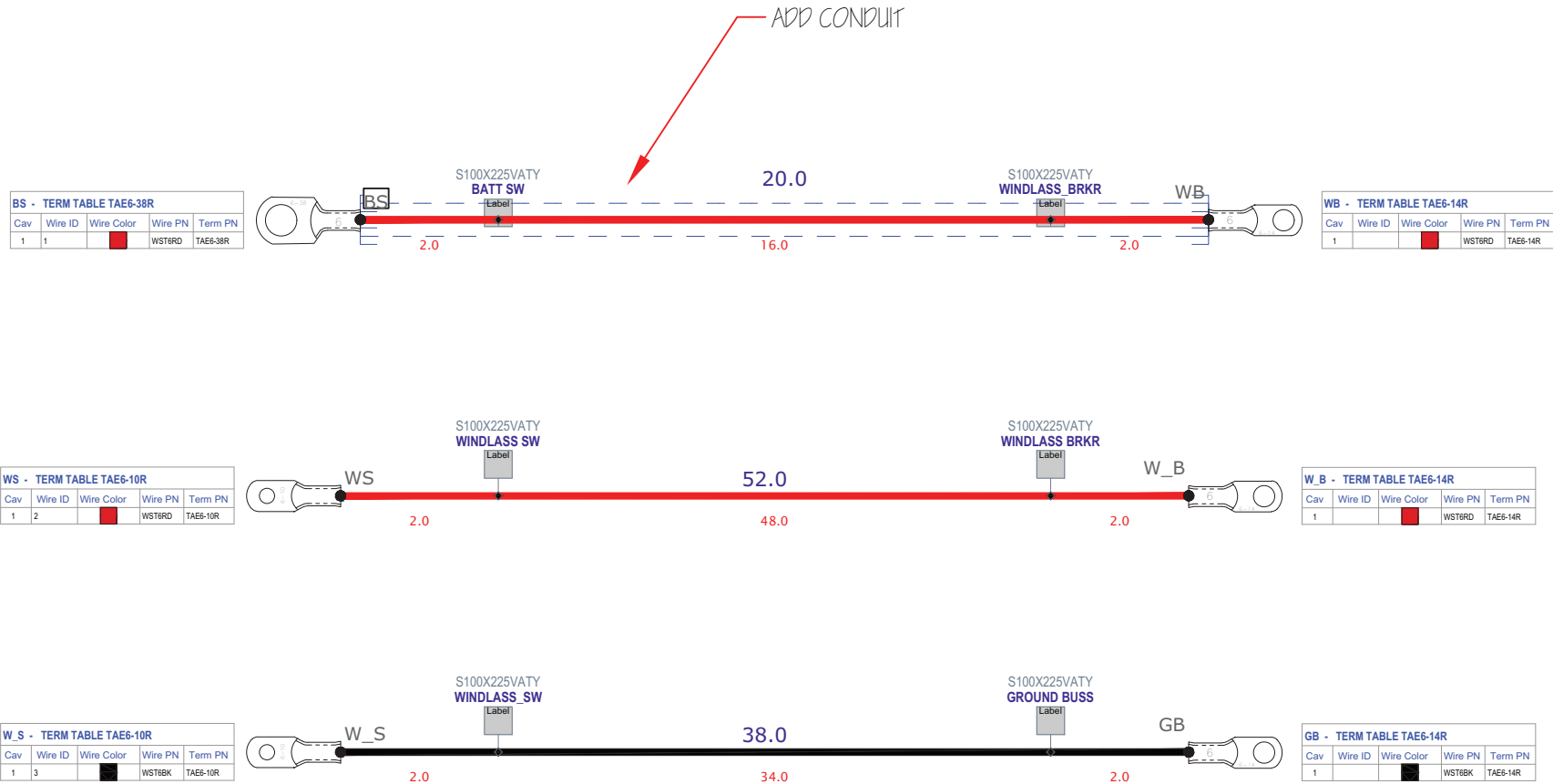

LABEL CABLES AS INDICATED

SEAFOX PT# 7940

WINDLASS OPTION

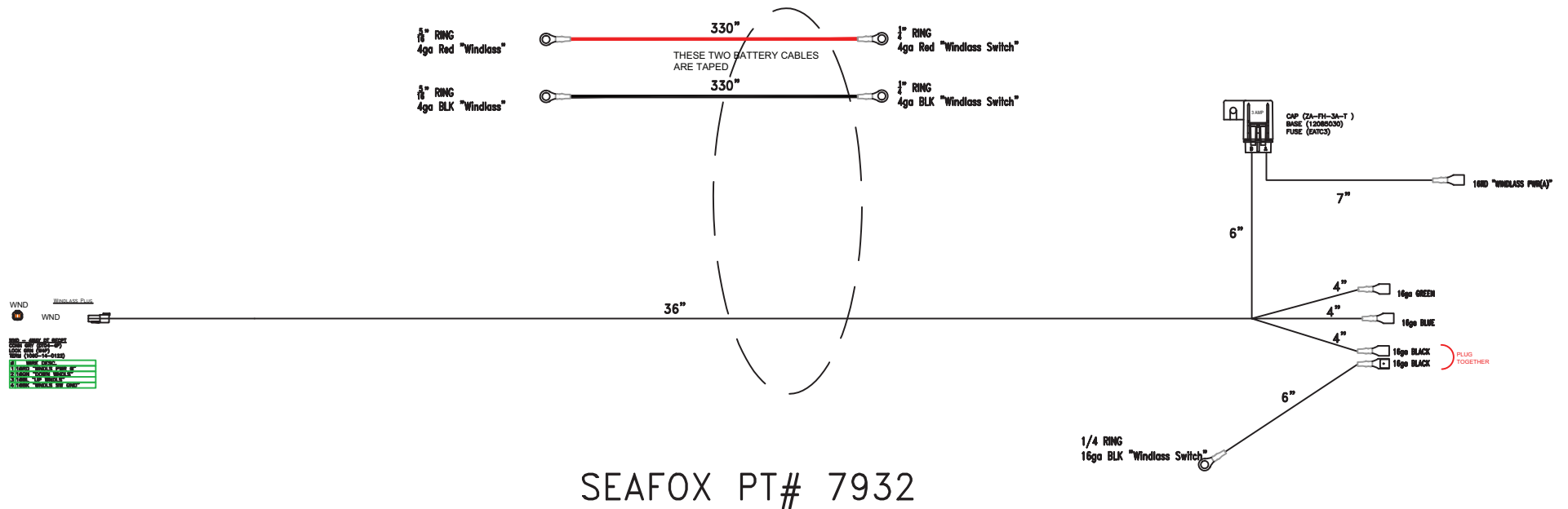

WINDLASS SWITCH PANEL

| REV # | DATE: | COMMENTS | BY: |
|-------|---------|---------------------------------------------------|-----|
| 0 | 3/06/18 | PRELIMINARY | MH |
| 0 | 8/28/18 | CHANGED THE SWITCHES TO BOCATECH | MH |
| A | 1/23/19 | CHANGED PANEL FROM LEXAN TO ALUM | MH |
| B | 5/26/20 | CHANGED TO GLOSS BLACK | MH |
| C | 7/29/22 | CHANGED MOUNTING HOLES AND ADDED SHOULDER WASHERS | MH |

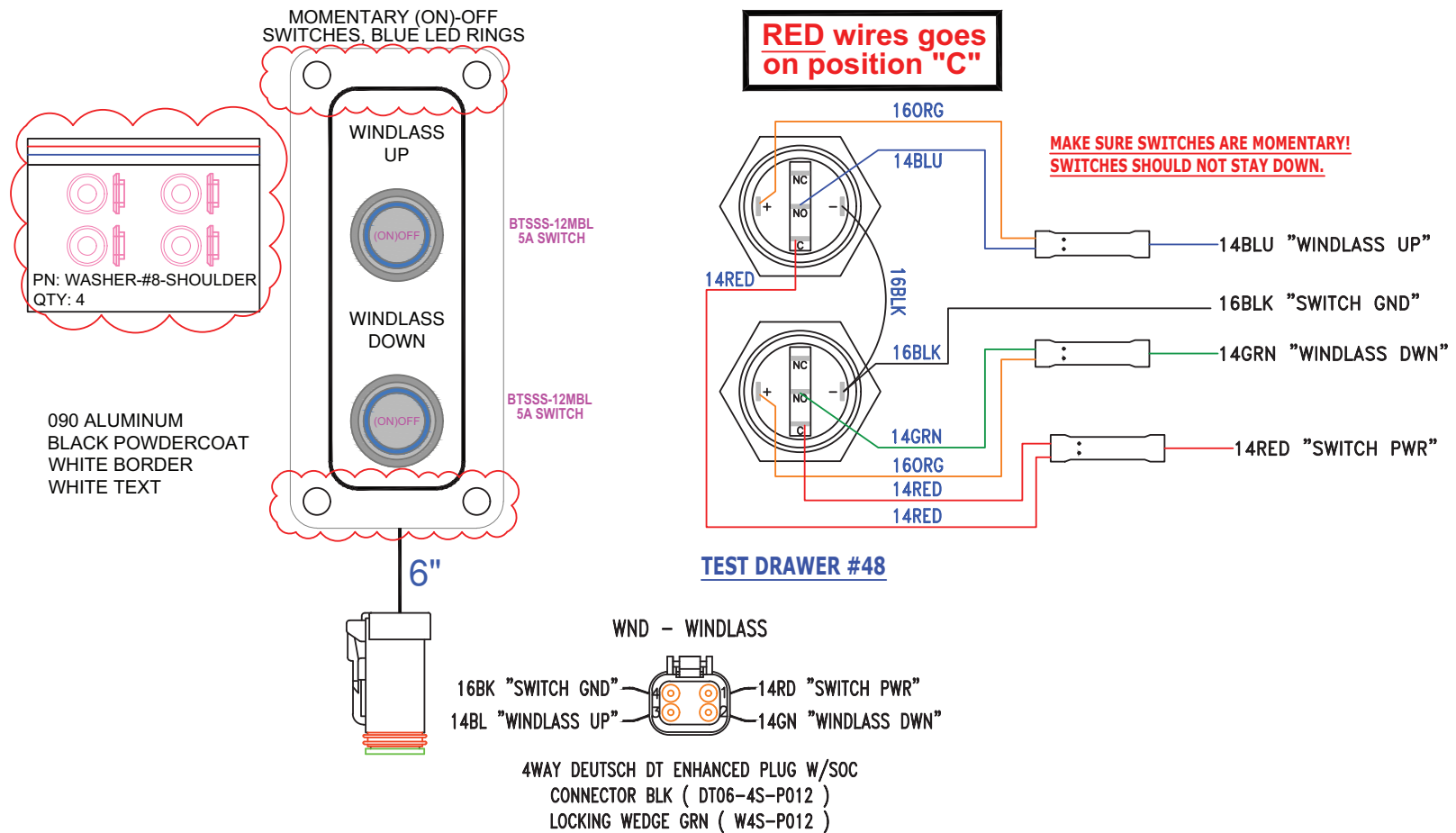

SEAFOX PT# 7488

WINDLASS DECK BOW PANEL

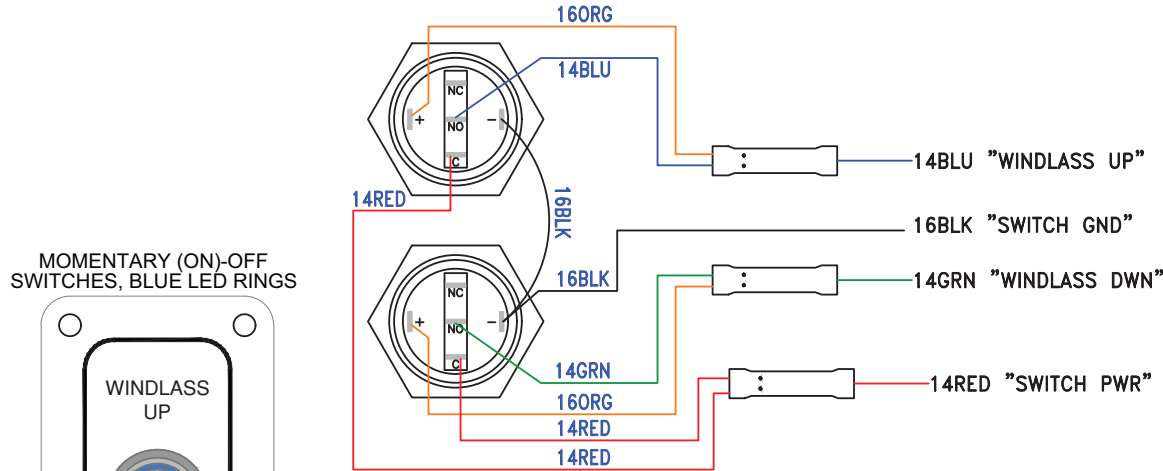

MOMENTARY (ON)-OFF SWITCHES, BLUE LED RINGS

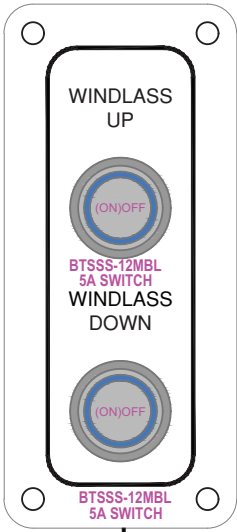

090 ALUMINUM
BLACK POWDERCOAT
WHITE BORDER
WHITE TEXT

PANEL SIDE

WND - WINDLASS



4WAY DEUTSCH DT ENHANCED PLUG W/SOC
CONNECTOR BLK (DT06-4S-P012)
LOCKING WEDGE GRN (W4S-P012)

HARNESS SIDE

WND - 4WAY DT RECPT
CONN GRY (DT04-4P)
LOCK GRN (W4P)
TERM (1060-14-0122)

| # | WIRE DESC. |
|---|---------------------|
| 1 | 14RD "WNDLS SW PWR" |
| 2 | 14GN "DOWN WNDLS" |
| 3 | 14BL "UP WNDLS" |
| 4 | 14BK "WNDLS SW GND" |

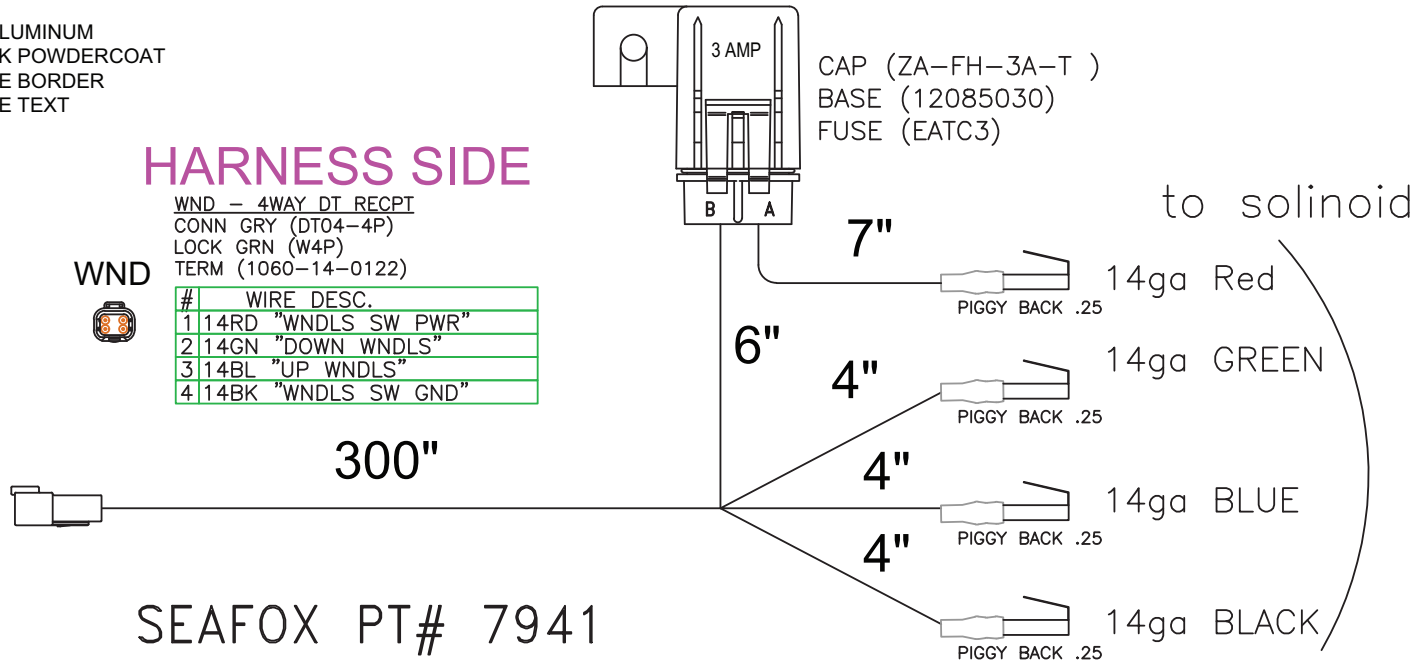

SEAFOX PT# 7941

TROLLING MOTOR HARNESS

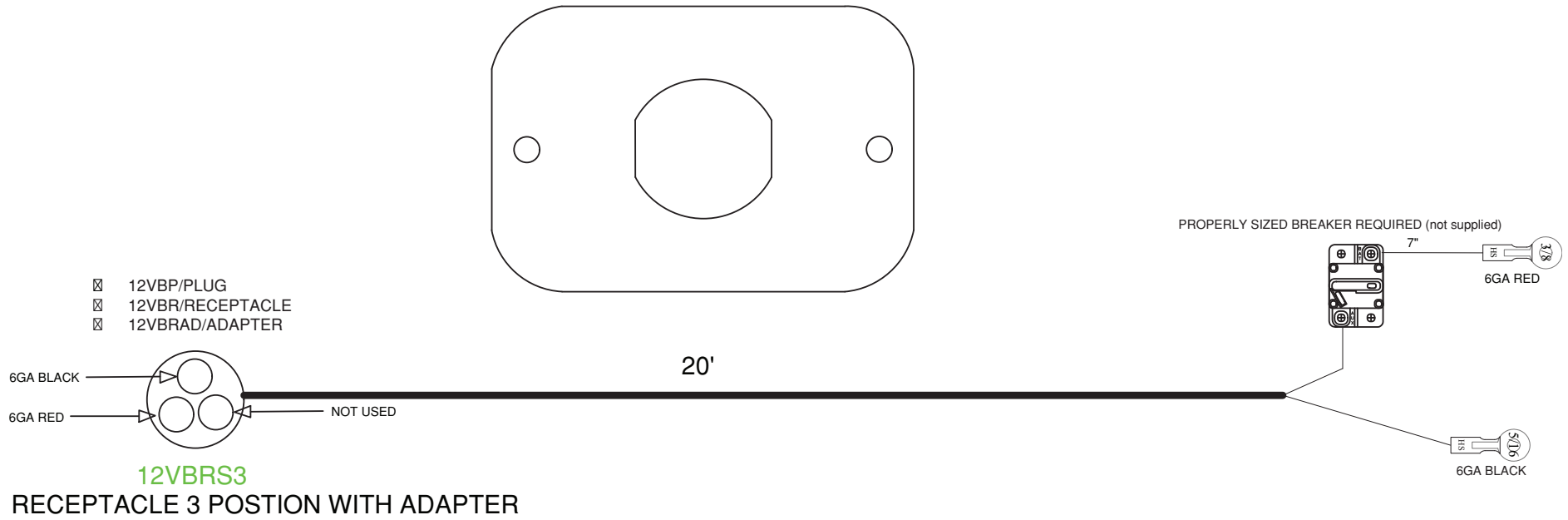

SF# 8830

ELECTRIC HEAD HARNESS

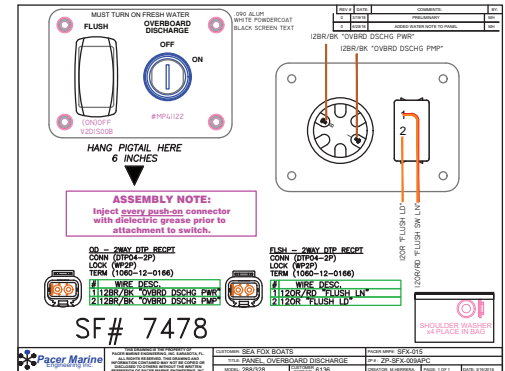
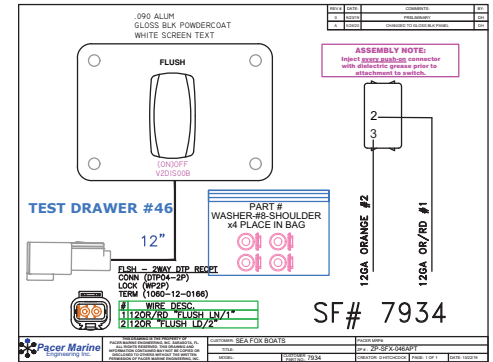
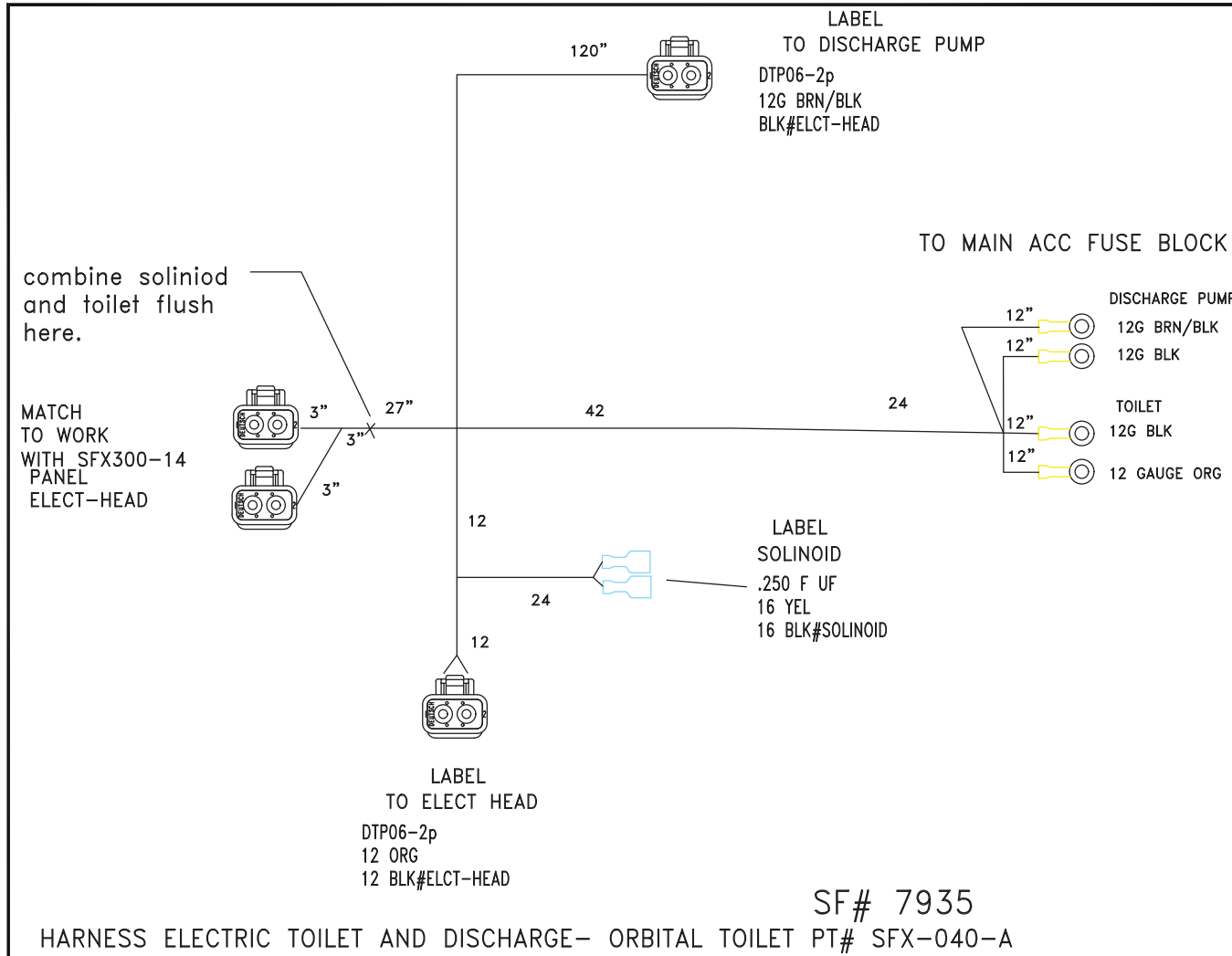

BATTERY WIRING

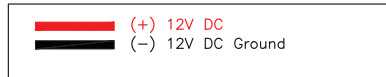

NOTE: UNDER NORMAL OPERATING CONDITIONS MAIN BATTERY SWITCH IS ON 1. IN LOW VOLTAGE SITUATIONS REFER TO THE BELOW EMERGENCY ENGINE START DIRECTIONS.

EMERGENCY ENGINE START

TO USE BATTERY #2 FOR EMERGENCY CRANKING PLACE SWITCH TO BOTH, OR TO 2 IF A SHORT IN THE MAIN BATTERY IS SUSPECTED,

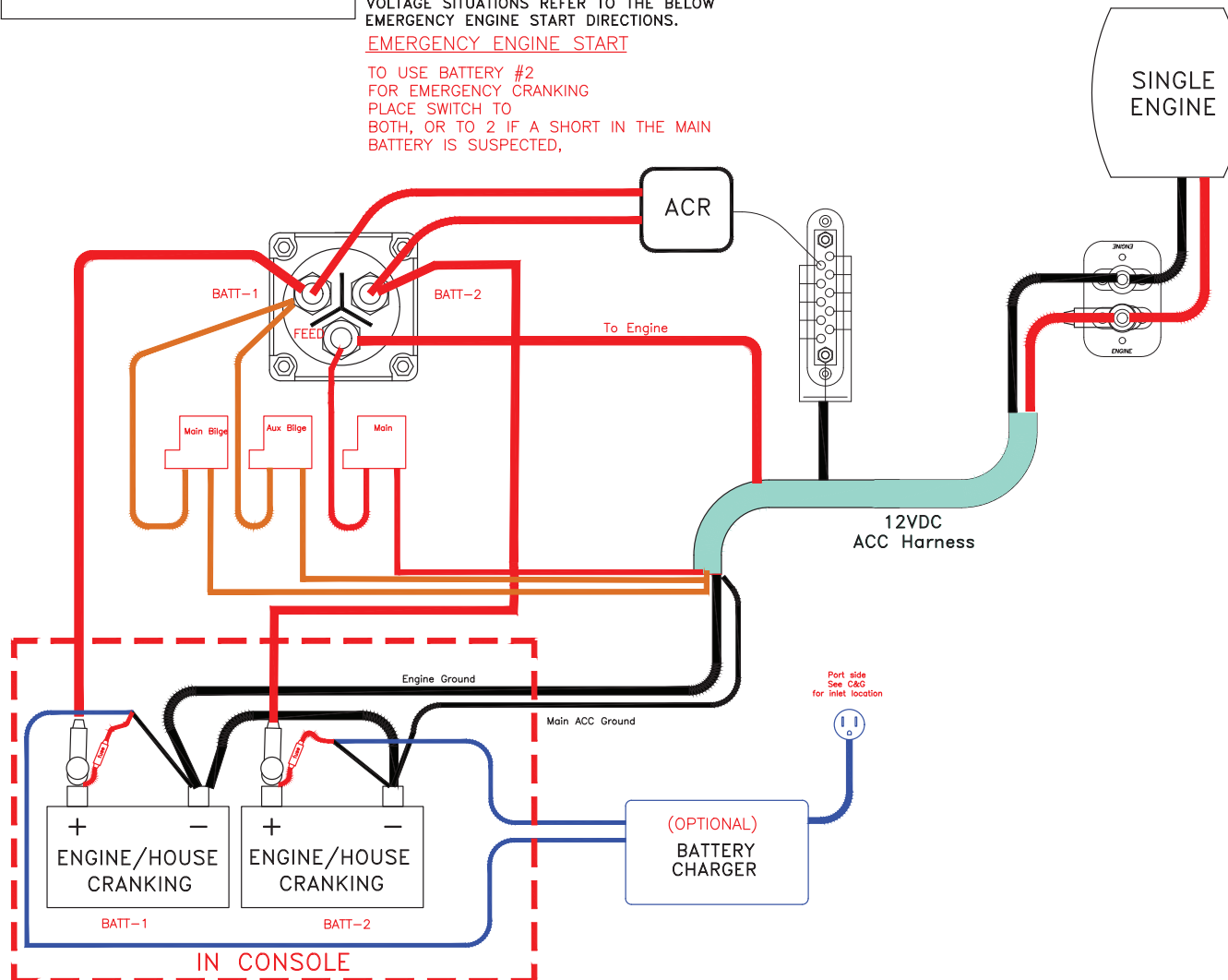

BATTERY WIRING

This Page Intentionally Left Blank

SEA  FOX
BOAT WORKS

Sea Fox Boat Company, Inc.
2550 Highway 52
Moncks Corner, SC 29461-5024

Telephone: 843-761-6090
www.seafoxboats.com

Ken Cook Co.
Printed in U.S.A.
Rev 0325