

**ZEPET**



# **Owner's Manual Supplement**

[www.seafoxboats.com](http://www.seafoxboats.com)

## **SEA FOX BOAT'S DISCLAIMER**

The following Owner's Manual is provided for information and educational purposes only and is not intended to offer or provide legal advice or create a contractual relationship between Sea Fox Boat Company and the owner of any Sea Fox brand vessel. Please beware that as a vessel owner you have non-delegable responsibilities regarding the safety, maintenance, fitness, and operation of your vessel and the extent of such responsibilities is ultimately determined by Federal law and regulations, the general maritime law of the United States, the laws and regulations of the states and territories of the United States, or the laws and regulations of the country where you operate your vessel. To fully understand your responsibilities as a vessel owner, and before operating or letting any third-party operate your vessel, we recommend that you consult the services of a qualified lawyer in admiralty and maritime law.

## TABLE OF CONTENTS

Introduction . . . . .	3	Electrical Schematics . . . . .	16
Specifications . . . . .	3	Main Switch Panel Helm . . . . .	16
Designated Occupant Seating . . . . .	4	Battery Switch Panel . . . . .	17
Safety Decals . . . . .	5	Main Breaker Panel . . . . .	18
Plumbing Schematics . . . . .	7	Electric Flush Panel . . . . .	19
Bilge Pumps . . . . .	7	Overboard Discharge Panel . . . . .	20
Deck Drains . . . . .	8	Awning In/Out Panel . . . . .	21
Hull Thru Hull Drains . . . . .	9	Main ACC Harness - Deck . . . . .	22
Waste System with Overboard Discharge . . . . .	10	Main ACC Harness - Deck (con't) . . . . .	23
Fresh Water Deck . . . . .	12	Bilge Harness . . . . .	24
Fresh Water Hull . . . . .	13	Hard Top Harness Panel Kit . . . . .	25
Raw Water Hull . . . . .	14	Amplifier Adapter Kit . . . . .	26
Fuel System . . . . .	15	Stove - 120V AC Panel . . . . .	27

This Page Intentionally Left Blank

## INTRODUCTION

**Congratulations and Welcome Aboard!** With so many boat brands to choose from, we want to congratulate you on your decision to choose Sea Fox Boats. For more than 28 years, Sea Fox offers the finest hand-crafted saltwater boats carefully balanced with the build-quality, features, styling and performance for the fairest price. Our passion for boating is evident in every model we make and we appreciate that you've noticed the Sea Fox difference.

We share your love for the moments spent on the water with friends and family, which is why every Sea Fox boat offers a unique blend of fishing/family options, technologies and innovative features. Your choice of a Sea Fox affirms that you have performed your research and compared the value of your model with the competition.

Whether you are new to the boating lifestyle or an old salt, we ask that **you and all other operators** read the owner's manual, this supplement, and all other literature provided with the boat **before** operating the boat or any equipment. We also recommend that all operators enroll in a boating safety course available online - see References and Contact Information in this section for education resources online.

This supplement contains model-specific information not included with the owner's manual. This manual is not intended to be a replacement for specific product literature provided by engine, accessory or other major equipment manufacturers, but rather to supplement that information.

Because of our philosophy of continuous product improvement, this manual serves as a general guide only, so the specifications and illustrations used may not match the equipment on your boat and are intended only as general reference views.

*We welcome you to the Sea Fox family and wish you many years of boating enjoyment!*

## SPECIFICATIONS

Max. Weight Capacity	Yacht Certification
Persons	Yacht Certification
Persons Weight	Yacht Certification
Max. HP	600 hp (447 kw)
L.O.A.	28' (8.5 m)
Beam	9' 8" (2.9 m)
Draft	18" (0.46 m)
Height, Keel to Top (Light Folded)	118" (3.0 m)
Height, Keel to Top (w/Outriggers)	121" (3.1 m)
Height, Keel to Top (w/Radar)	122" (3.1 m)
Bridge Clearance w/TopMax	8' 4" (2.54 m)
Max. Weight Boat [w/batteries, fluids, gear, largest motor(s)]	9,660 lbs (4382 kg)
Fuel Tank Capacity	147 gal (556 L)
Freshwater Tank Capacity	23 gal (87 L)
Holding Tank Capacity	12 gal (45 L)

## DESIGNATED OCCUPANT SEATING

Be sure all passengers are properly seated in designated seating positions and not riding on the bow, bow pulpit, deck, gunwale or rear sun deck while underway. Passengers must use hand-holds and use caution when riding in the bow. Move to the aft passenger seats during rough water operation or if visibility is restricted.

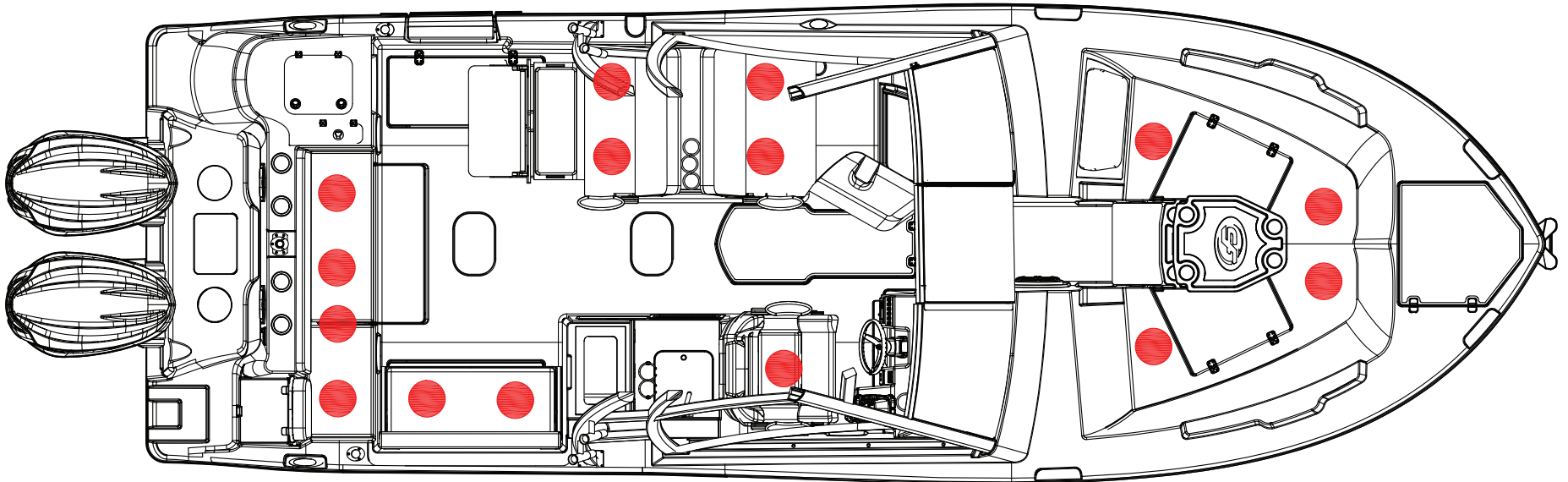

● = Seat position

SFOX-0225

## SAFETY DECALS

9

9

9 **FRESH WATER**

5 **FRESH WATER**

2

9 **RAW WATER**

6 **BATTERY CHARGER**

3 **NO WOOD!  
NO ROT!**

2 **WARNING**  
Operating, servicing and maintaining a recreational engine vessel can expose you to chemicals including engine exhaust, carbon monoxide, pesticides, and lead, which are known to the State of California to cause cancer and birth defects or other reproductive harm. To minimize exposure, avoid breathing exhaust, operate your vessel in a well-ventilated area and wear gloves or wash your hands frequently when servicing this vessel. For more information go to [www.cdwrmsps.ca.gov/chem.htm](http://www.cdwrmsps.ca.gov/chem.htm).

2 **DISCHARGE OF OIL PROHIBITED**  
THE FEDERAL WATER POLLUTION CONTROL ACT PROHIBITS THE DISCHARGE OF OIL OR OILY WASTE INTO OR UPON THE NAVIGABLE WATERS OF THE UNITED STATES, OR THE WATERS OF THE CONTIGUOUS ZONE, OR WHICH MAY AFFECT NATURAL RESOURCES BELONGING TO, APPERTAINING TO, OR UNDER THE EXCLUSIVE MANAGEMENT AUTHORITY OF THE UNITED STATES, IF SUCH DISCHARGE CAUSES A FILM OR DISCOLORATION OF THE SURFACE OF THE WATER OR CAUSES A SLUDGE OR EMULSION BENEATH THE SURFACE OF THE WATER. VIOLATORS ARE SUBJECT TO SUBSTANTIAL CIVIL PENALTIES AND/OR CRIMINAL SANCTIONS INCLUDING FINES AND IMPRISONMENT.

2 **WARNING**  
It is illegal for any vessel to dump plastic ANYWHERE in the ocean or navigable waters of the United States. Annex V of MARPOL TREATY is an International Law for a cleaner, safer marine environment. Violation of these requirements is a Class D Felony and may result in a civil penalty, up to \$25,000 fine and imprisonment.

U.S. lakes, rivers, bays or sounds and 3 miles from shore	3 to 12 miles	12 to 25 miles	Outside 25 miles
<b>ILLEGAL TO DUMP:</b> Plastic and packing materials that float; also if not ground to less than one inch	<b>ILLEGAL TO DUMP:</b> Plastic	<b>ILLEGAL TO DUMP:</b> Dunnage, lining and packing materials that float.	<b>ILLEGAL TO DUMP:</b> Plastic
Paper Rags Crocery Dumage Food	Metal Paper Crocery Metal Food		

Regional state and local regulations may further restrict the disposal of garbage. The discharge of all garbage into the Great Lakes or their connecting or tributary waters is prohibited.

9 **DANGER**  
Carbon monoxide (CO) can cause brain damage or death.  
Engine and generator exhaust contains odorless and colorless carbon monoxide gas. Carbon monoxide will be around the back of the boat when engines or generators are running. Move to fresh air. If you feel nausea, headache, dizziness, or drowsiness.

1 **WARNING**  
Avoid Serious or Fatal Injury  
Shut & Lock Window  
When Speed Exceeds 5 m.p.h.

1 **WARNING**  
Do not stand on or jump off of lounge/footrest. Watch your hands and fingers when opening and closing cover. Maximum seated weight capacity 250 lbs.

1 **WARNING**  
CONTENTS CAN BE UNDER PRESSURE. AVOID SERIOUS INJURY OR DEATH FROM FIRE OR EXPLOSION. OPEN SLOWLY IN WELL VENTILATED AREA. NO SMOKING OR OPEN FLAMES.

2 **WARNING**  
Avoid Serious or Fatal Injury  
Lock Swivel On Seat  
When Speed Exceeds 5 m.p.h.

1 **WARNING**  
CARBON MONOXIDE (CO) CAN CAUSE BRAIN DAMAGE OR DEATH.  
Carbon monoxide can be present in the cabin. Signs of carbon monoxide poisoning include nausea, headache, dizziness, drowsiness, and lack of consciousness.  
MOVE TO FRESH AIR if anyone shows signs of carbon monoxide poisoning.  
USE AVAILABLE HANDRAILS AND HANDHOLDS to avoid falling.

6 **NOTICE**  
SHUT OFF VALVE(S) LOCATED BEHIND ACCESS PANEL. CLOSE VALVE(S) WHEN NOT IN USE.

6 **NOTICE**  
SHUT OFF VALVE(S) LOCATED BEHIND ACCESS PANEL. CLOSE VALVE(S) WHEN NOT IN USE.

2 **WARNING**  
Failure to follow these warnings could cause severe injury or death.  
WEAR SAFETY LANYARD at all times while operating boat to prevent unintended boat operation.  
NEVER OPERATE WHILE UNDER THE INFLUENCE of drugs or alcohol.  
DO NOT OVERLOAD THE BOAT. ENSURE THAT WEIGHT IS PROPERLY AND EVENLY DISTRIBUTED fore and aft and on both sides of the boat to avoid pond handling sudden loss of control, swaying and/or capsizing.  
PASSENGERS SHOULD WEAR U.S. COAST GUARD APPROVED LIFE JACKETS.  
MAKE SURE THAT ALL PASSENGERS ARE PROPERLY SEATED WHILE UNDERWAY. To avoid passengers being overboard or being ejected from the boat, do not allow passengers to sit on seat backs, gunwales or outboard deck edges while boat is moving.  
REDUCE SPEED BEFORE ATTEMPTING SUDDEN OR SHARP TURNS.  
AND MAINTAIN SAFE SPEEDS in water conditions and environments at all times. Maneuverability at high speeds is limited, and sudden turns may cause loss of control.  
KEEP PROPER LOOKOUT AND SAFE DISTANCE for the conditions at all times to avoid collisions.  
OBEY APPLICABLE NAVIGATION RULES AND BOATING LAWS.  
USE CAUTION AND PROPER LIGHTING during nighttime boating and boating in adverse weather.  
READ THE OWNER'S MANUAL, AND COMPLETE THE BOATER'S PRE-OPERATION CHECKLIST prior to boat operation.

2 **WARNING**  
Failure to follow these warnings could cause SERIOUS INJURY OR DEATH.  
REMAIN PROPERLY SEATED AND HOLD ON to avoid being ejected from the boat. Do not sit on seat backs, gunwales or outboard deck edges.  
WEAR U.S. COAST GUARD APPROVED LIFE JACKETS.  
DO NOT OVERLOAD THE BOAT. OCCUPANTS AND GEAR MUST BE PROPERLY AND EVENLY DISTRIBUTED fore and aft, and on both sides of the boat. Improper loading and/or overloading may result in poor handling, sudden loss of control, swaying and/or capsizing.  
REFER TO AND OBEY THE DESIGNATED OCCUPANT SEATING POSITIONS that are illustrated by the manufacturer for your specific model.  
OBEY THE OPERATOR at all times.  
DO NOT RESTRICT THE OPERATOR'S VISION.  
DO NOT DEPART THE VESSEL without informing the operator.

2 **WARNING**  
Failure to follow these warnings could cause SERIOUS INJURY OR DEATH.  
REMAIN PROPERLY SEATED AND HOLD ON to avoid being ejected from the boat. Do not sit on seat backs, gunwales or outboard deck edges.  
WEAR U.S. COAST GUARD APPROVED LIFE JACKETS.  
DO NOT OVERLOAD THE BOAT. OCCUPANTS AND GEAR MUST BE PROPERLY AND EVENLY DISTRIBUTED fore and aft, and on both sides of the boat. Improper loading and/or overloading may result in poor handling, sudden loss of control, swaying and/or capsizing.  
REFER TO AND OBEY THE DESIGNATED OCCUPANT SEATING POSITIONS that are illustrated by the manufacturer for your specific model.  
OBEY THE OPERATOR at all times.  
DO NOT RESTRICT THE OPERATOR'S VISION.  
DO NOT DEPART THE VESSEL without informing the operator.

3 **WARNING**  
Leaking fuel is a fire and explosion hazard.

4 **DANGER**  
ROTATING PROPELLER CAN CAUSE SERIOUS INJURY OR DEATH. SHUT OFF MOTOR WHEN NEAR PERSONS IN WATER.

4 **DANGER**  
ROTATING PROPELLER CAN CAUSE SERIOUS INJURY OR DEATH. SHUT OFF MOTOR WHEN NEAR PERSONS IN WATER.

6 **NOTICE**  
SHUT OFF VALVE(S) LOCATED BEHIND ACCESS PANEL. CLOSE VALVE(S) WHEN NOT IN USE.

4 **NOTICE**  
SHUT OFF VALVE(S) LOCATED BEHIND ACCESS PANEL. CLOSE VALVE(S) WHEN NOT IN USE.

5 **NON POTABLE WATER**

5 **NON POTABLE WATER**

4 **NOTICE**  
THIS BOAT IS EQUIPPED WITH AN OPTIONAL DIRECT OVERBOARD DISCHARGE VALVE. DISCHARGING OF SEWAGE DIRECTLY OVERBOARD IS FOR USE WHERE APPROVED ONLY.

4 **NOTICE**  
THIS BOAT IS EQUIPPED WITH AN OPTIONAL DIRECT OVERBOARD DISCHARGE VALVE. DISCHARGING OF SEWAGE DIRECTLY OVERBOARD IS FOR USE WHERE APPROVED ONLY.

8 **WARNING**  
PINCH POINT  
Watch your hands and fingers when opening and closing cover.  
AVOID PERSONAL INJURY SECURE GATE/DOOR WHEN BOAT IS UNDERWAY, ENSURE LADDER IS SECURED TO DECK PRIOR TO USING IF EQUIPPED.

7 **WARNING**  
AVOID PERSONAL INJURY  
DO NOT BE OUTSIDE GATE/DOOR WHEN BOAT IS UNDERWAY.

1 **WARNING**  
AVOID PERSONAL INJURY  
LOCK LATCH WIND DAM DOOR IN THE OPEN & CLOSED POSITION WHEN BOAT IS UNDERWAY.

4 **NOTICE**  
FIRST AID KIT INSIDE

4 **NOTICE**  
FIRST AID KIT INSIDE

5 **DANGER**  
HOT GRILL SURFACE MAY CAUSE SEVERE BURNS.  
WHEN THE GRILL IS POWERED ON, THE SURFACE WILL BE HOT.  
TURN THE POWER OFF AND ALLOW THE GRILL SURFACE TO COOL BEFORE TOUCHING OR CLEANING.  
COVERING A HOT GRILL SURFACE AND NOT PROPERLY CLEANING THE DRIP TRAY COULD CAUSE A FIRE HAZARD.  
GRILL COUNTERTOP COVER MAY MELT OR CATCH FIRE IF EXPOSED TO HIGH HEAT FROM THE GRILL.  
TURN OFF THE GRILL, AND ALLOW THE SURFACE TO COOL BEFORE COVERING AND/OR OPERATING THIS VESSEL.  
CLEAN DRIP TRAY AFTER EACH USE.

1 **WARNING**  
Moving parts can crush and cut. Keep hands clear while operating track.

1 **WARNING**  
Moving parts can crush and cut. Keep hands clear while operating track.

4 **WARNING**  
Moving parts can crush and cut. Keep hands clear while operating track.

4 **WARNING**  
Moving parts can crush and cut. Keep hands clear while operating track.

Manufactured by **SEA FOX**

268/288 Traveler Decal Kit

- 1= COCKPIT FRONT
- 2=CONSOLE
- 3= FUEL FILL
- 3= HEAD COMPARTMENT
- 4= COCKPIT MID SHIP PORT
- 5= GALLEY STBD
- 6= COCKPIT AFT
- 7= TRANSOM GATE
- 8= DIVE DOOR
- 9=TRANSOM

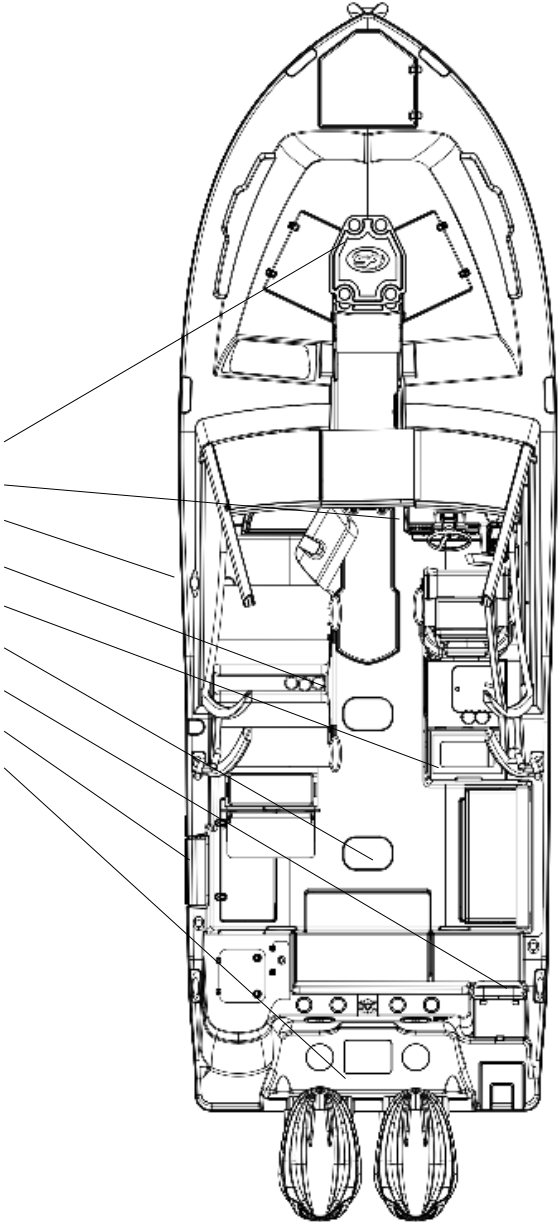



## PLUMBING SCHEMATICS

### BILGE PUMPS

Note: Drawings for general reference only.  
Not to scale. Subject to change.

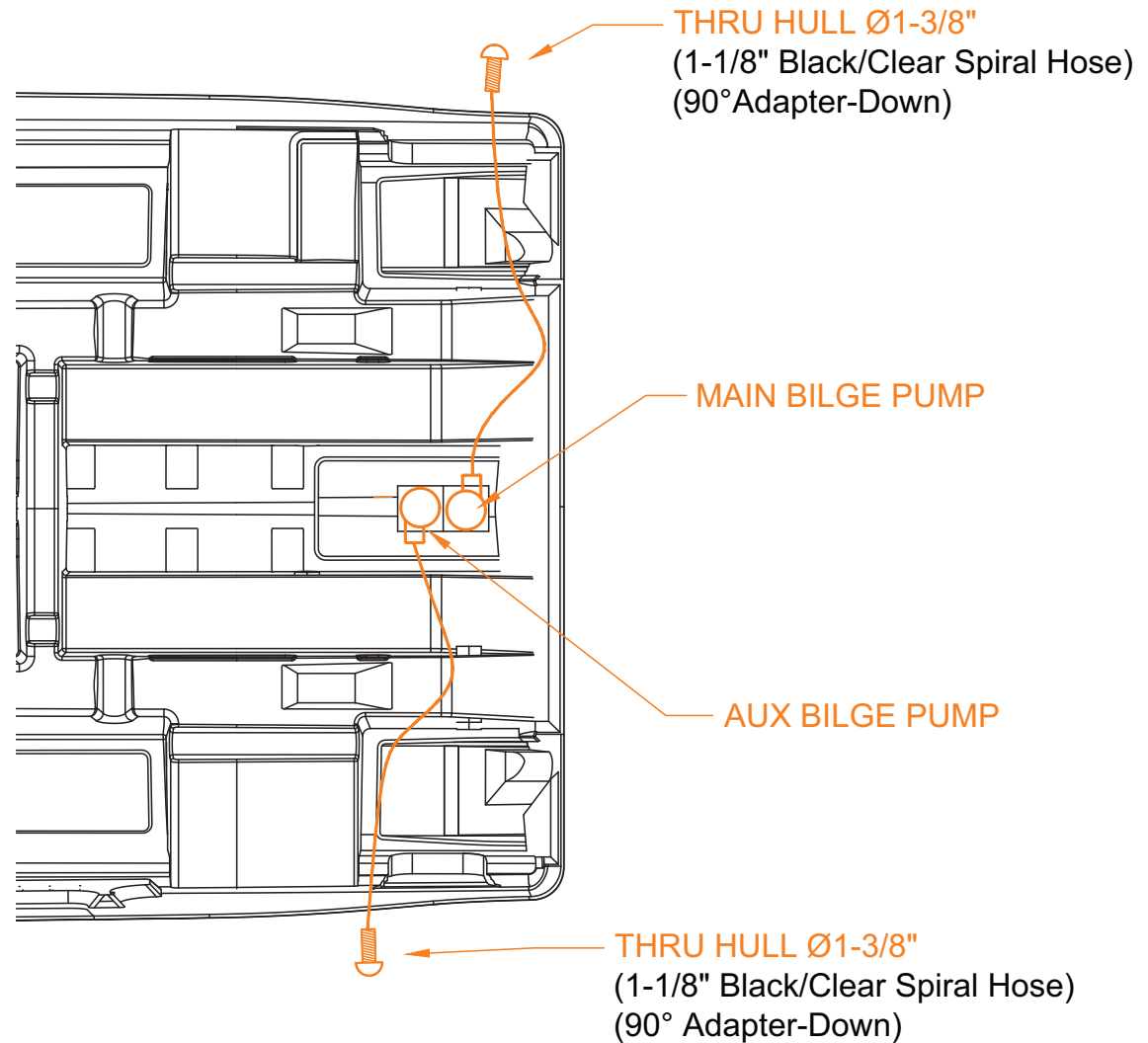

## DECK DRAINS

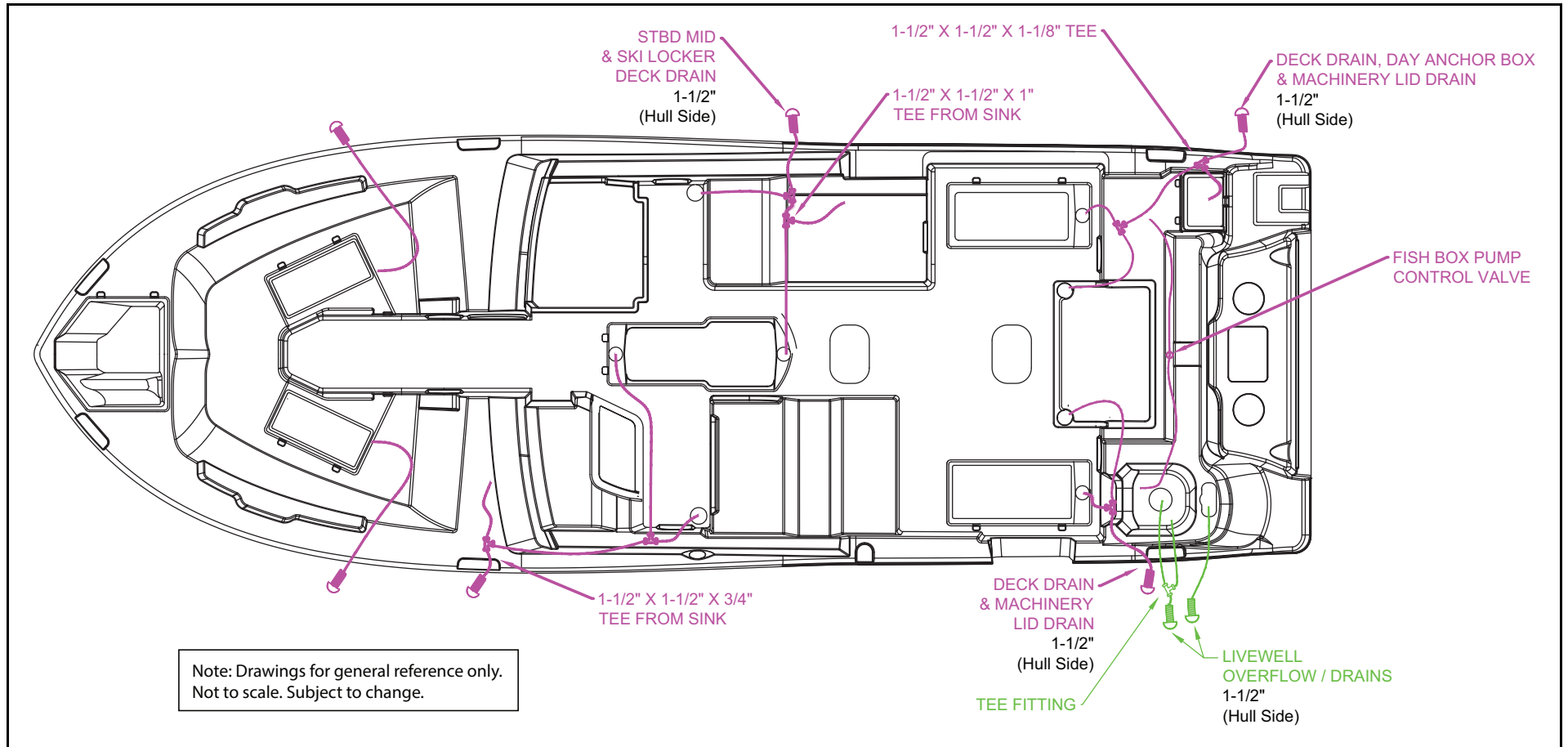

## HULL THRU HULL DRAINS

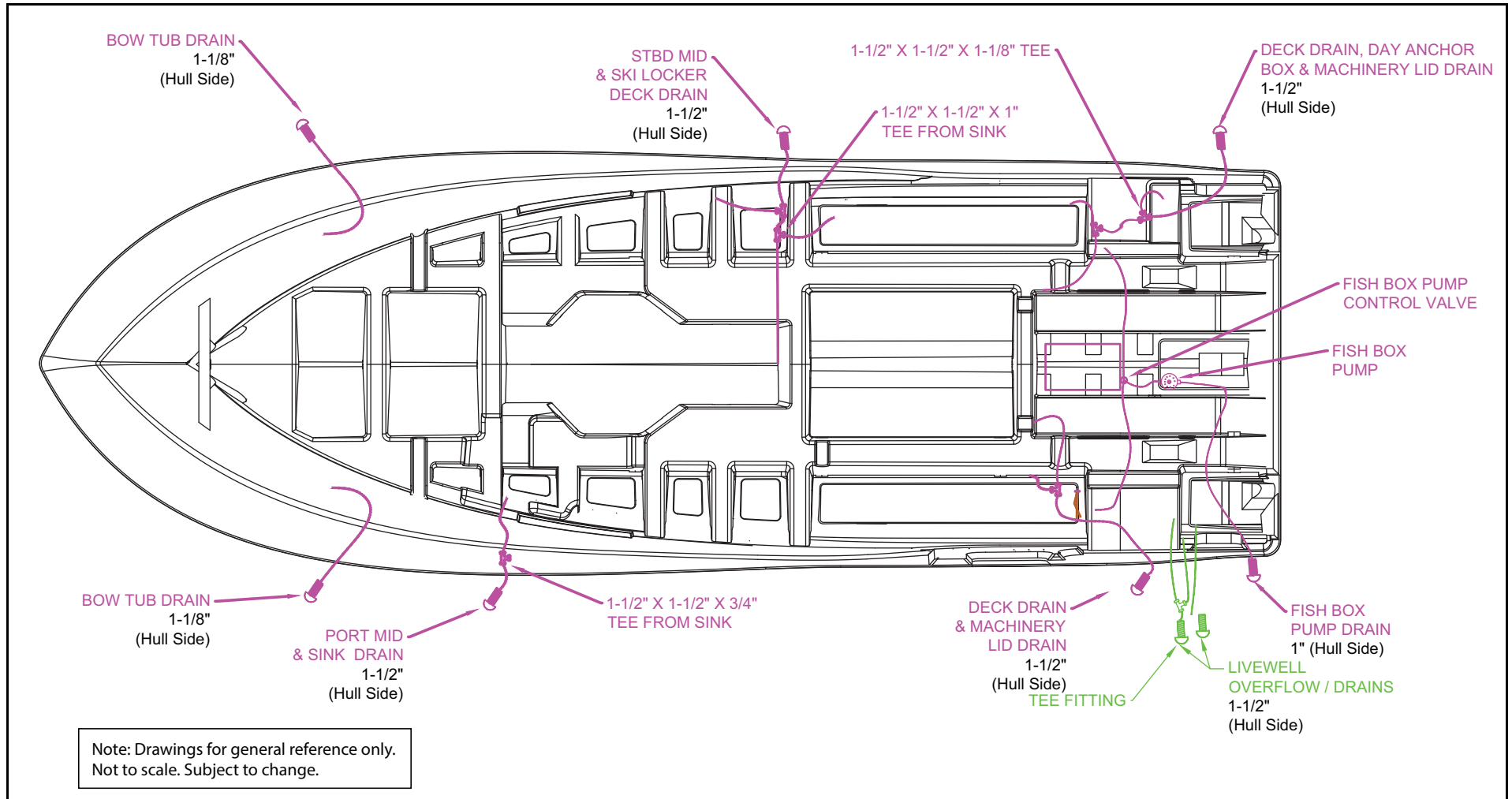

## WASTE SYSTEM WITH OVERBOARD DISCHARGE

### Hull Plumbing

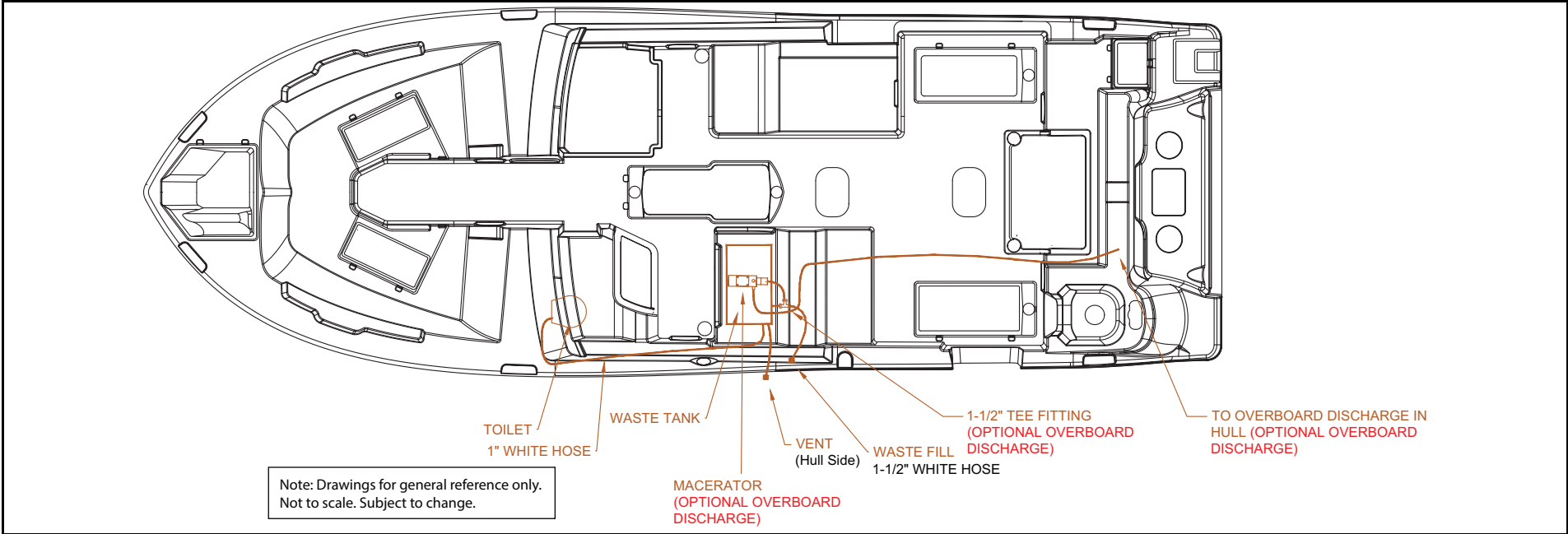

## Deck Plumbing

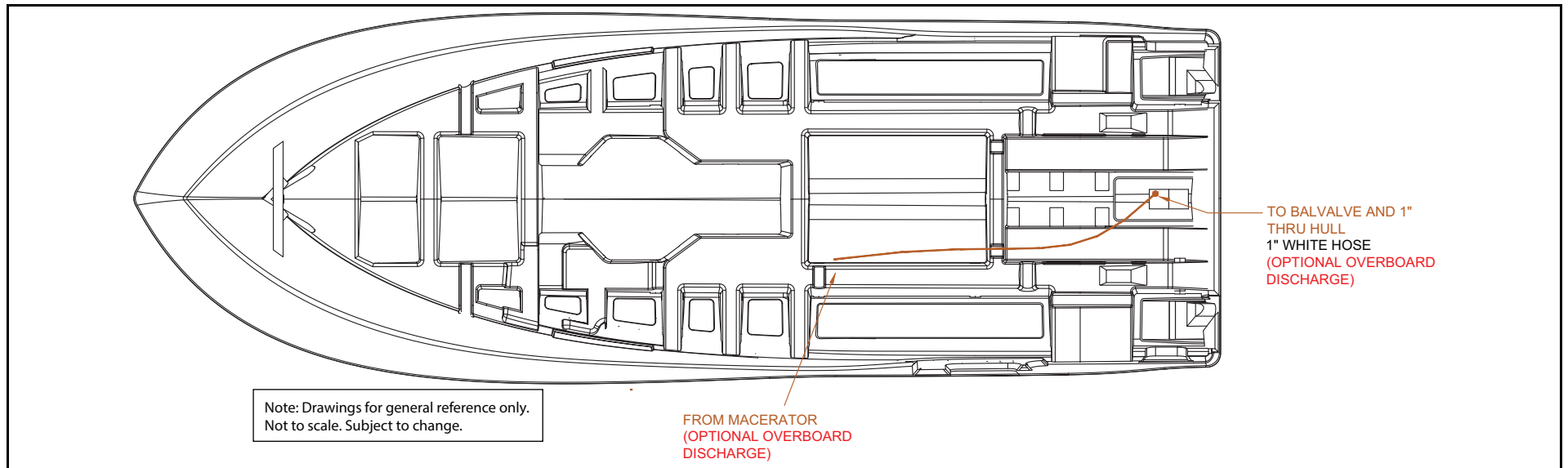

## FRESH WATER DECK

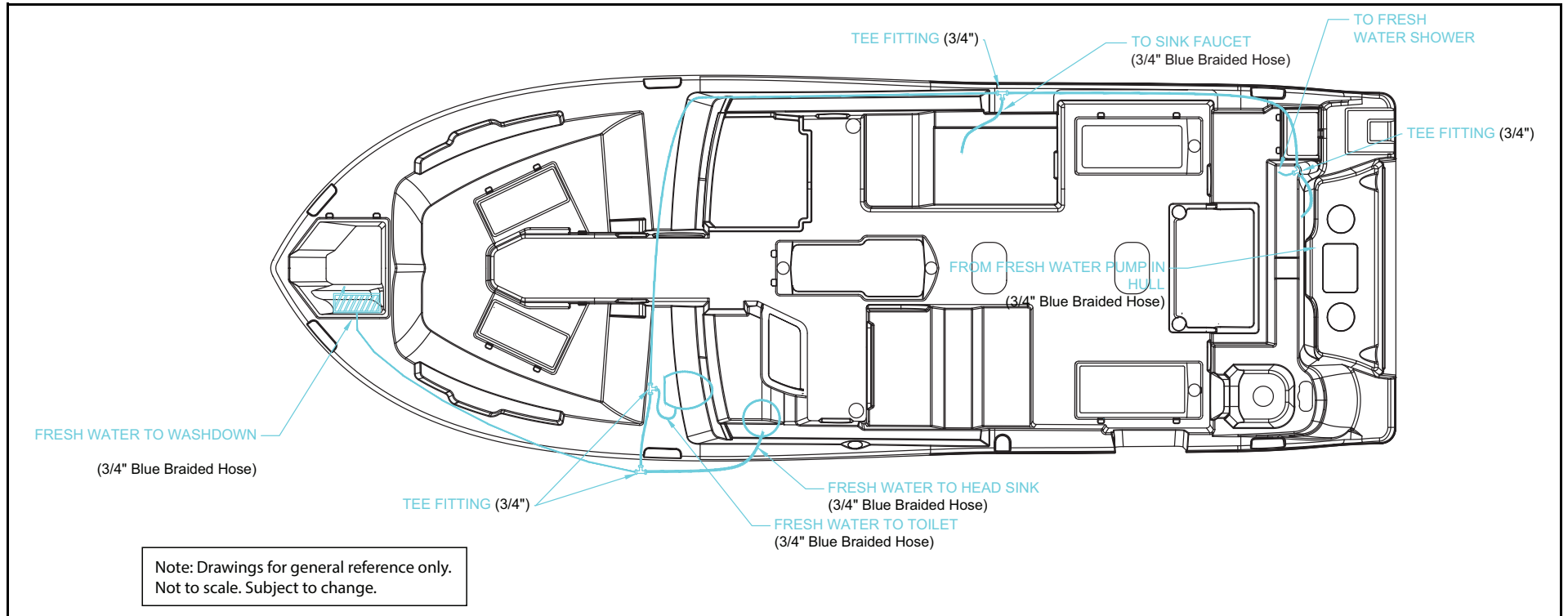

## FRESH WATER HULL

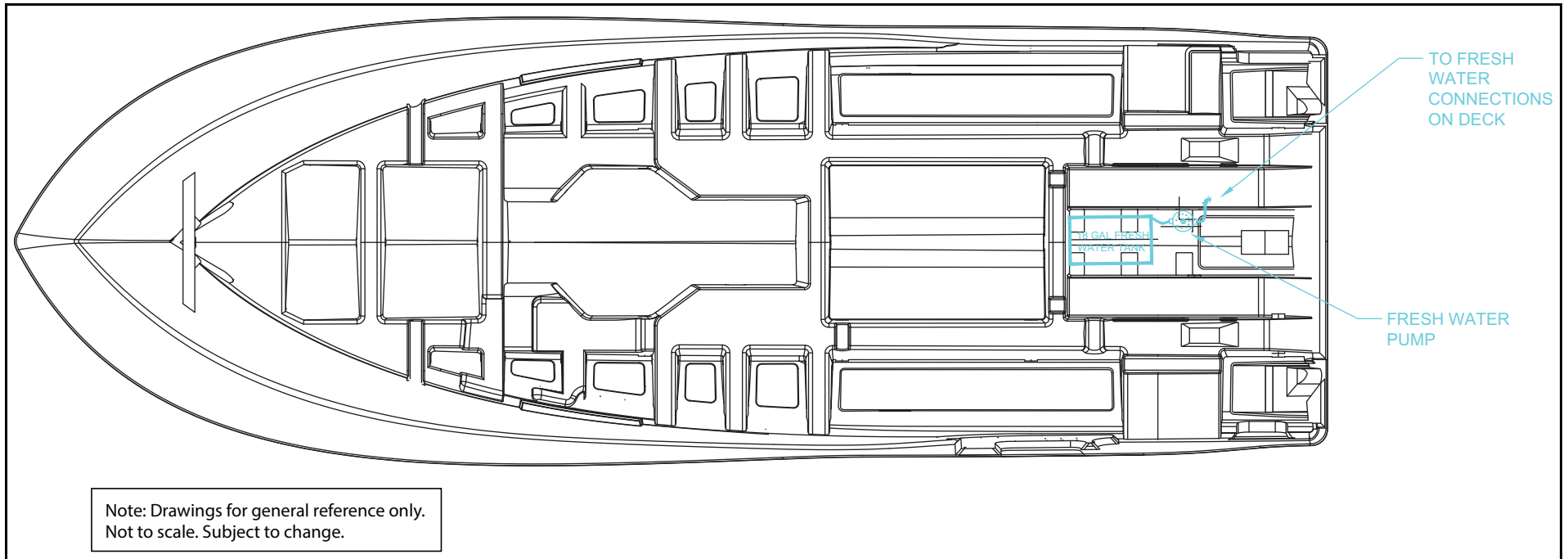

## RAW WATER HULL

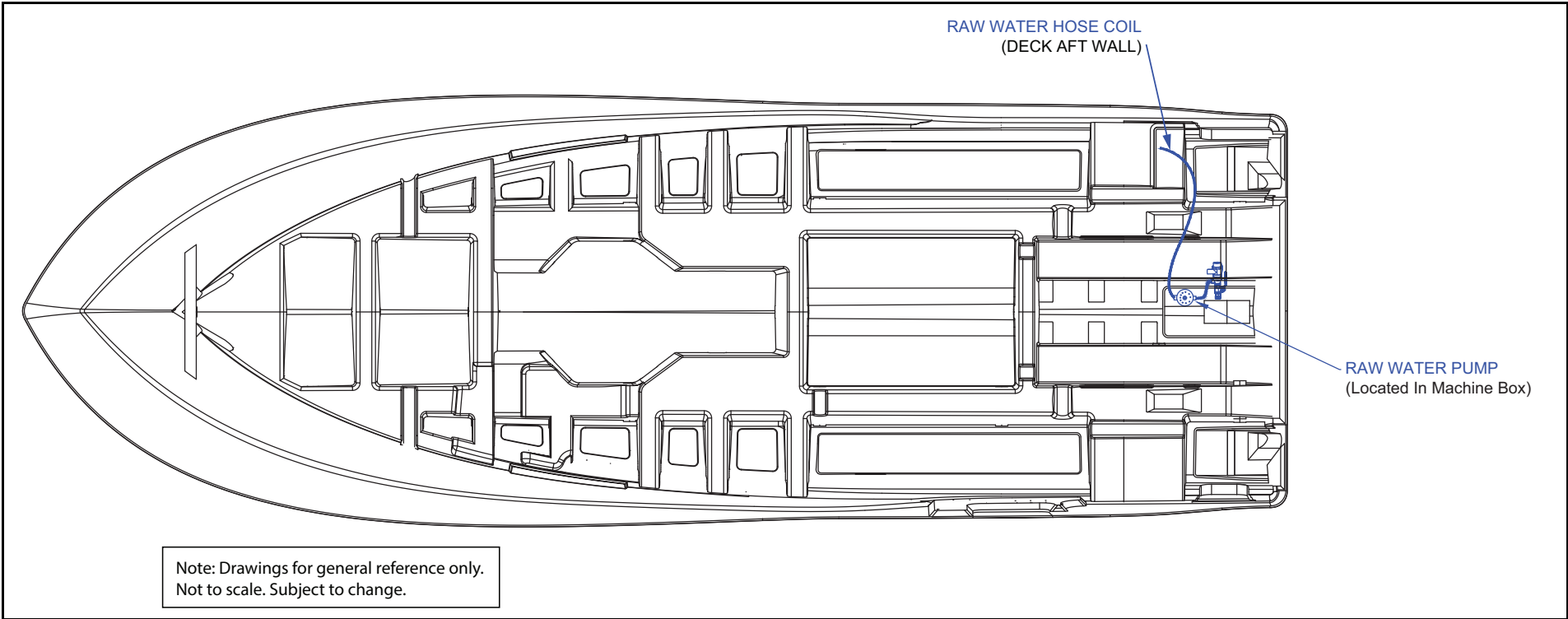



## FUEL SYSTEM

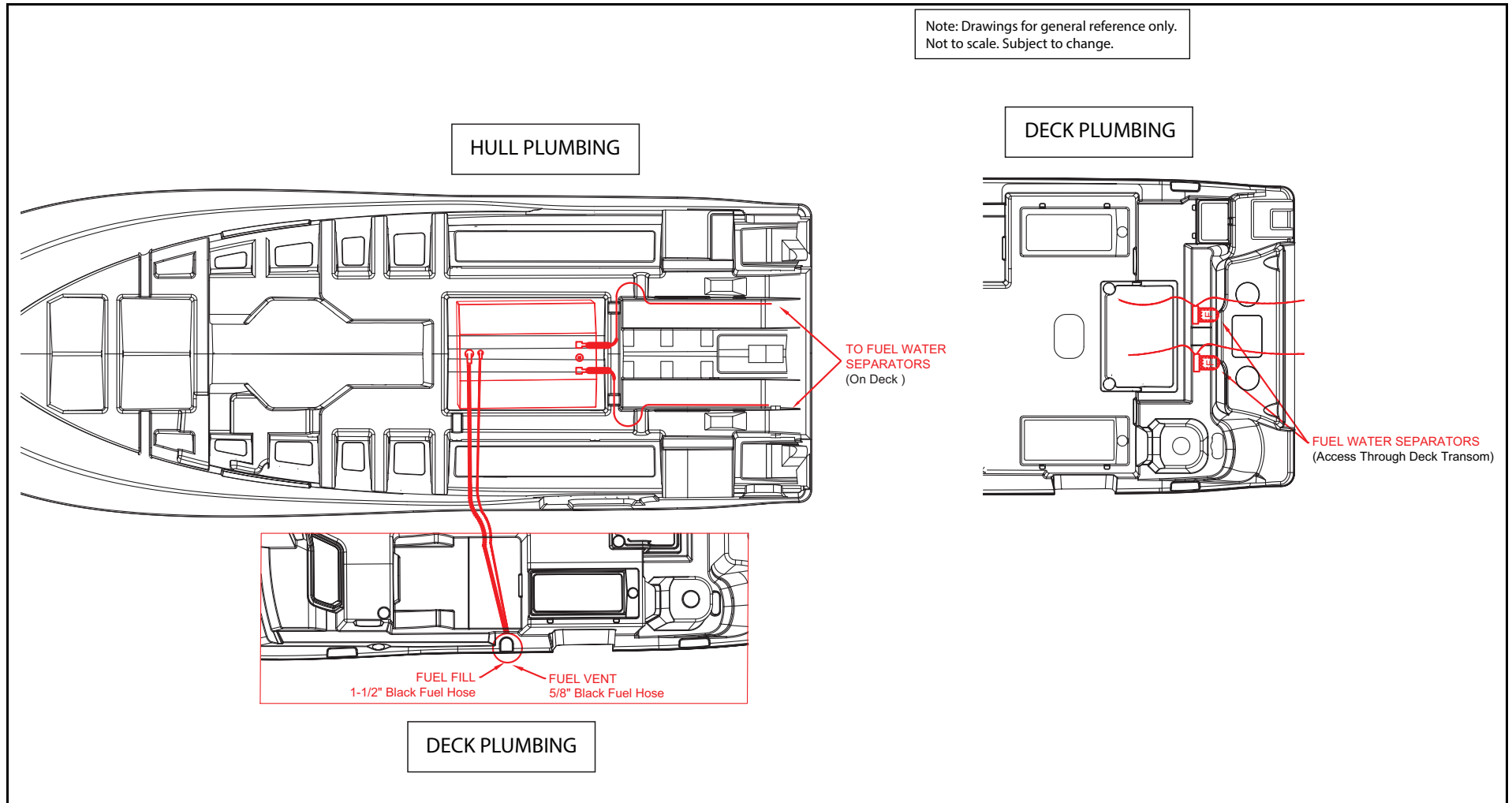

## ELECTRICAL SCHEMATICS

### MAIN SWITCH PANEL HELM

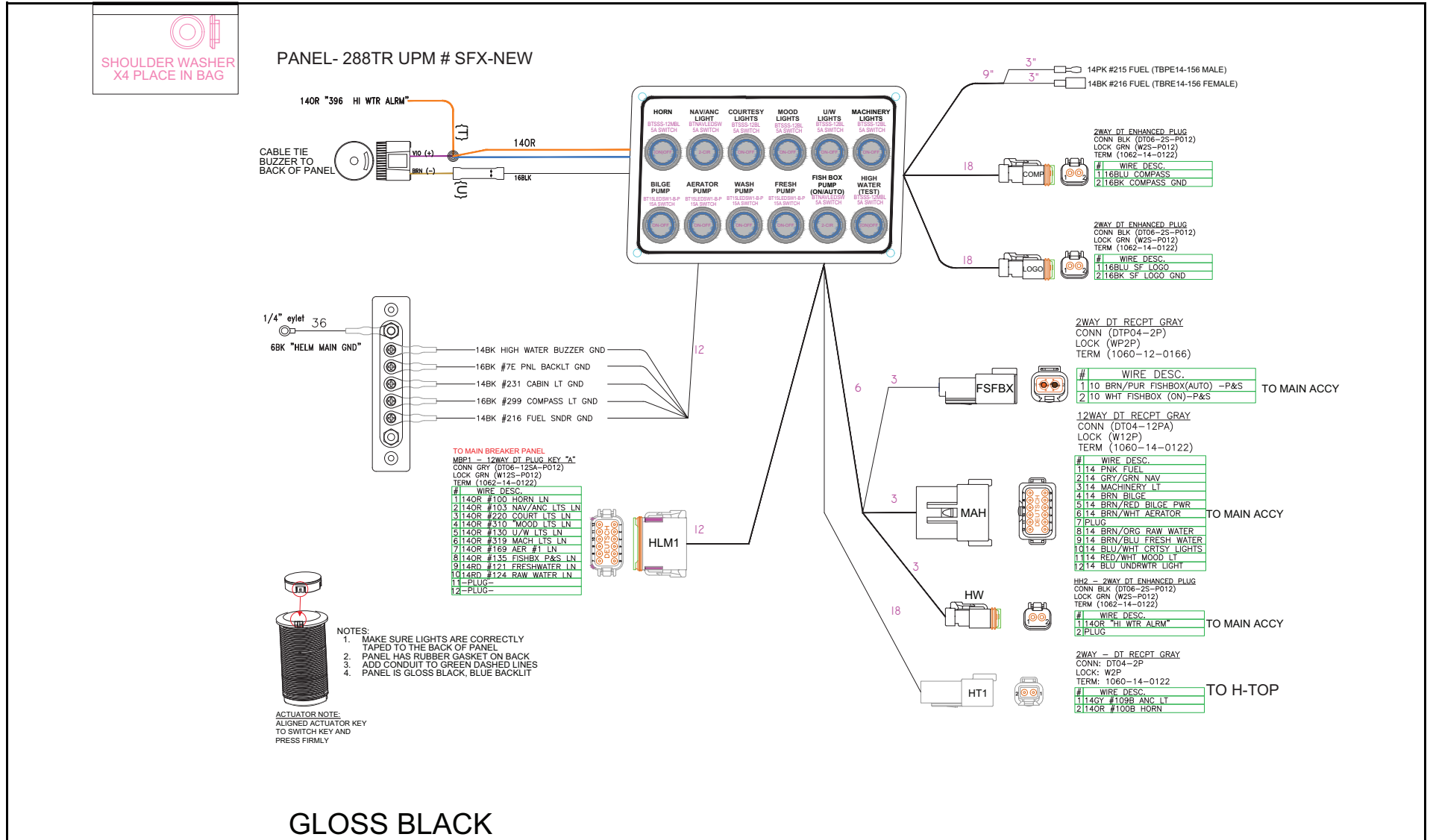

## BATTERY SWITCH PANEL



**ALL WIRES DROP OFF AT THE BOTTOM OF THE PANEL**  
**ALL WIRE 14G UNLESS SPECIFIED**

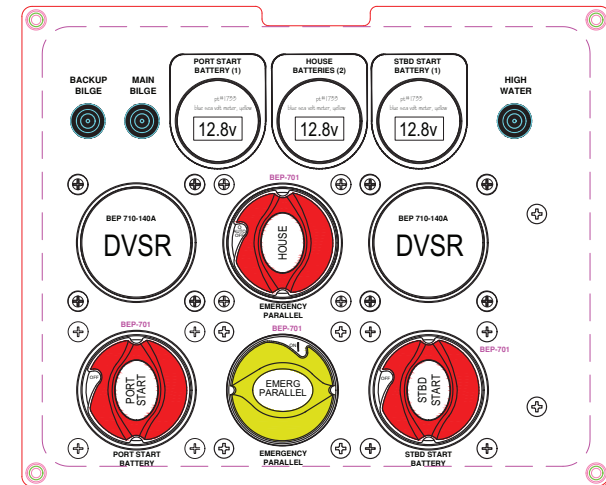
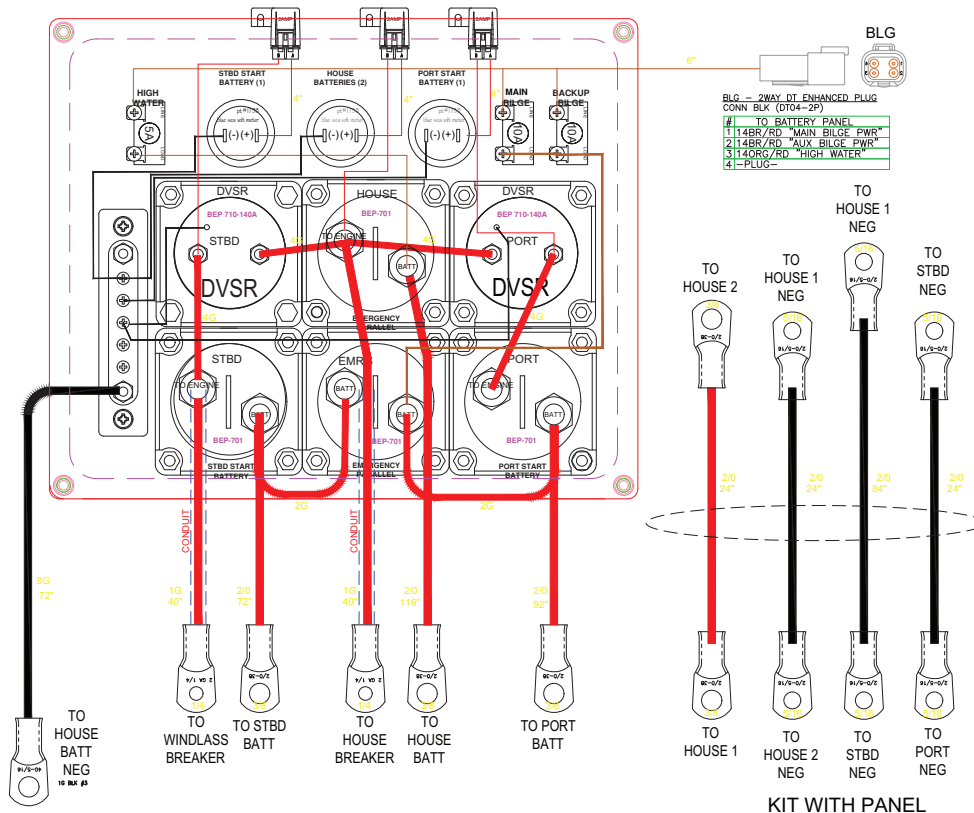
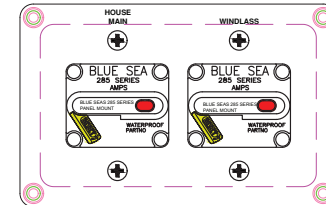
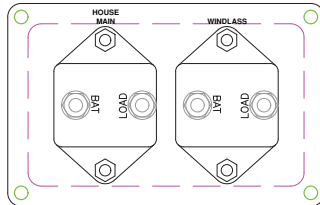

**LOCTITE ON ALL SCREWS**  
**DIELECTRIC GREASE ON PUSH-ON CONNECTORS**  
**ALL WIRE LENGTH FROM BOTTOM OF PANEL**



**ALL NON DEUTSCH CONNECTORS- HEAT SHRINK STYLE**

**KIT WITH PANEL**

## MAIN BREAKER PANEL

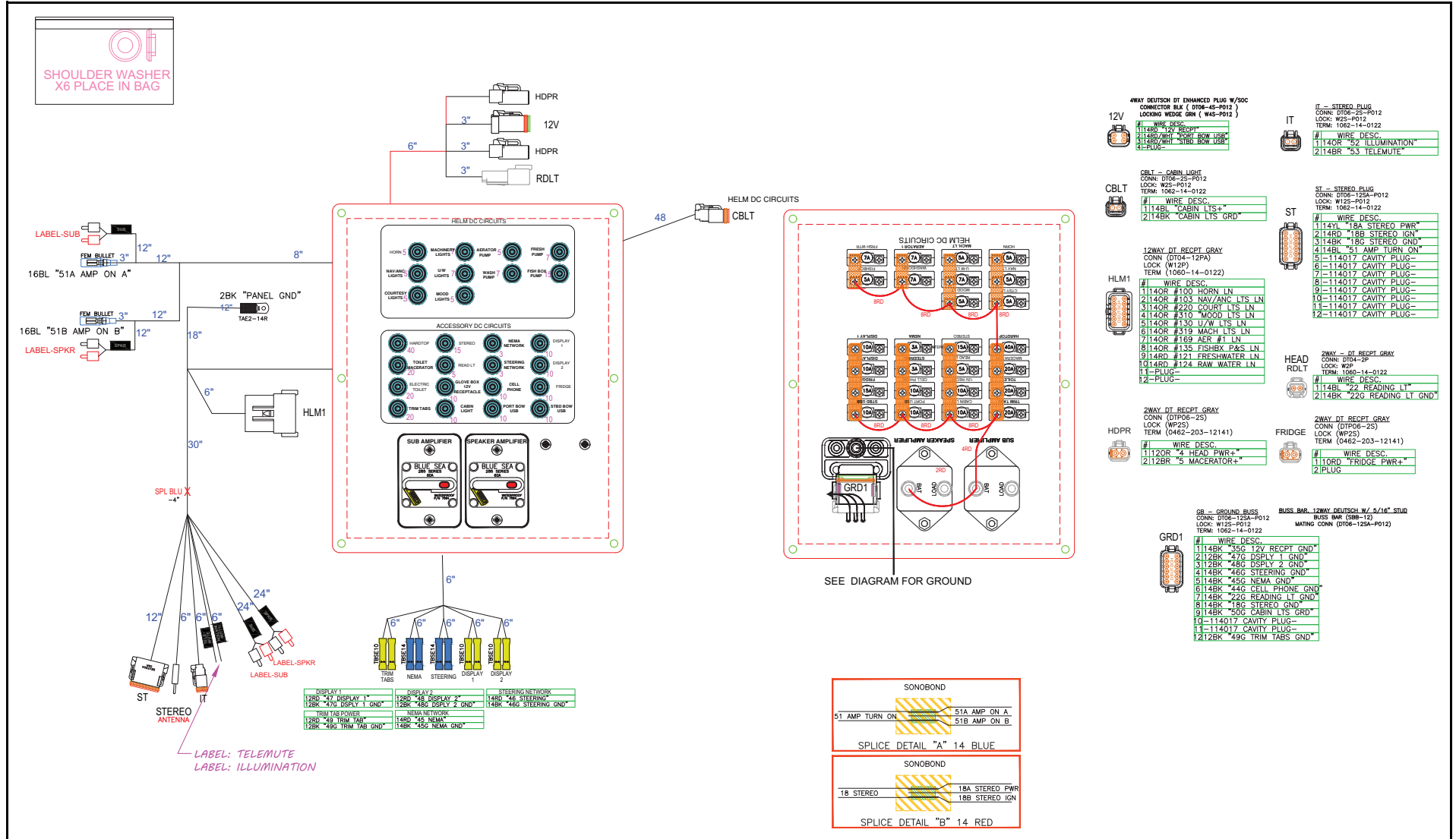

## ELECTRIC FLUSH PANEL

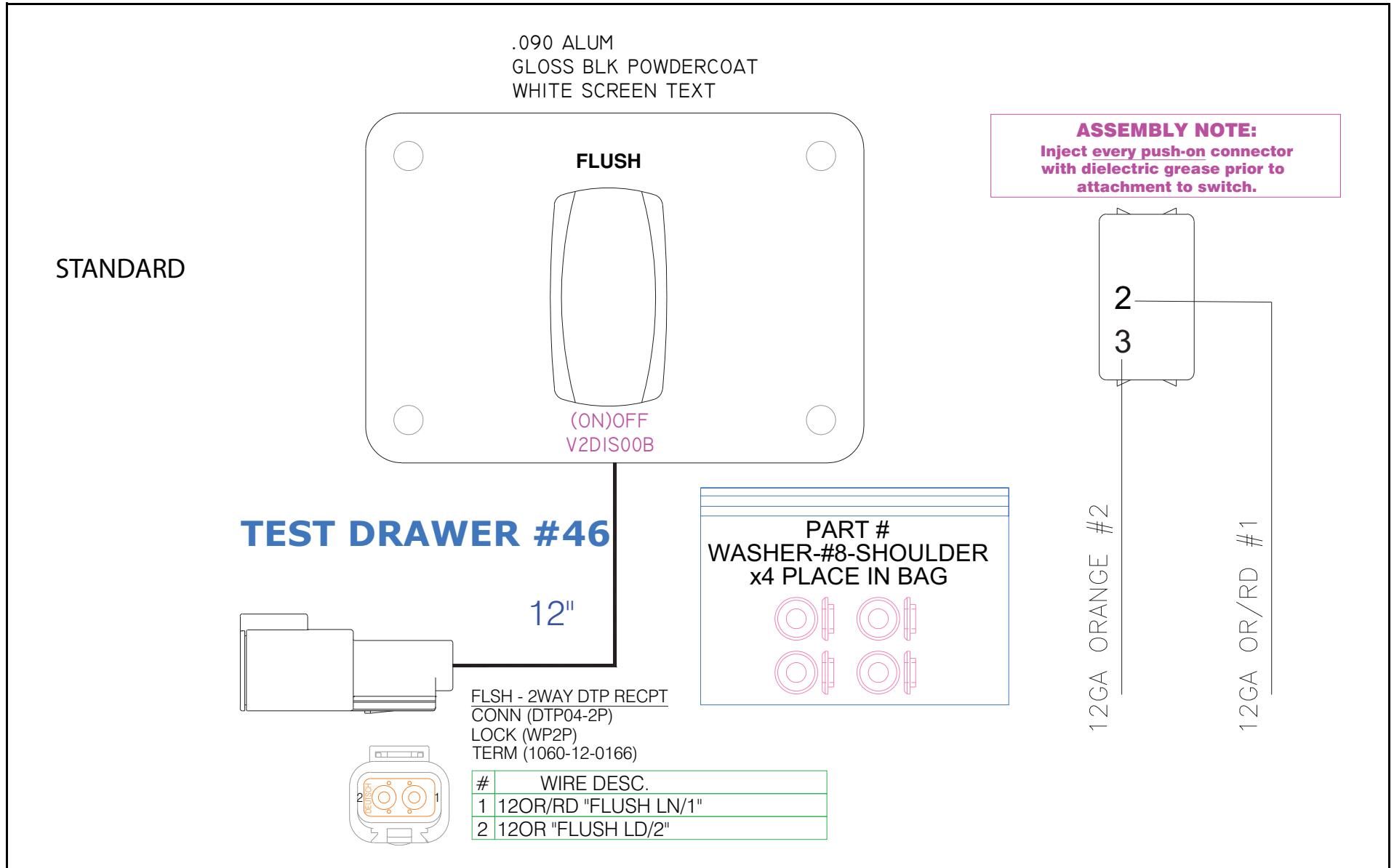

## OVERBOARD DISCHARGE PANEL

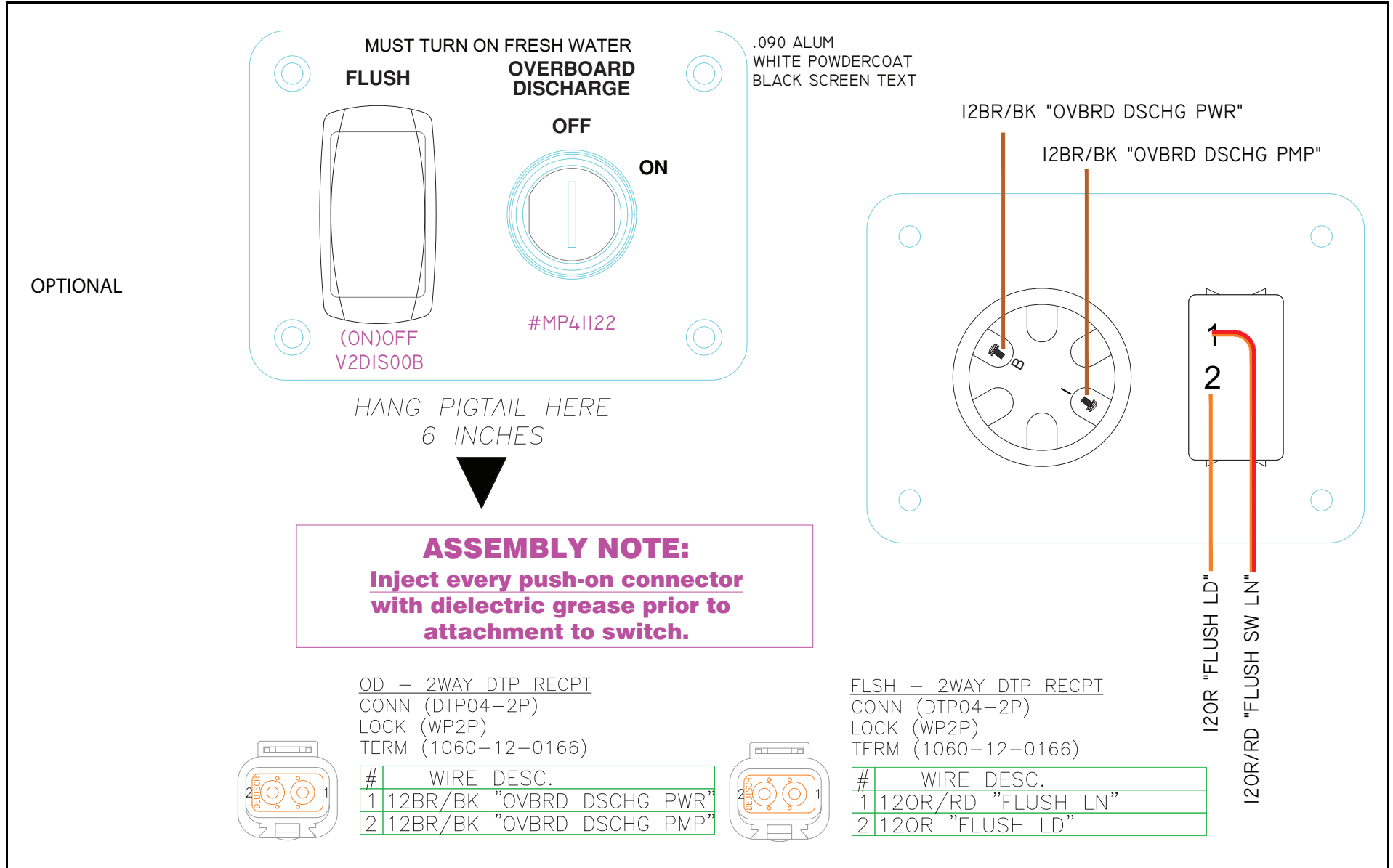

## AWNING IN/OUT PANEL

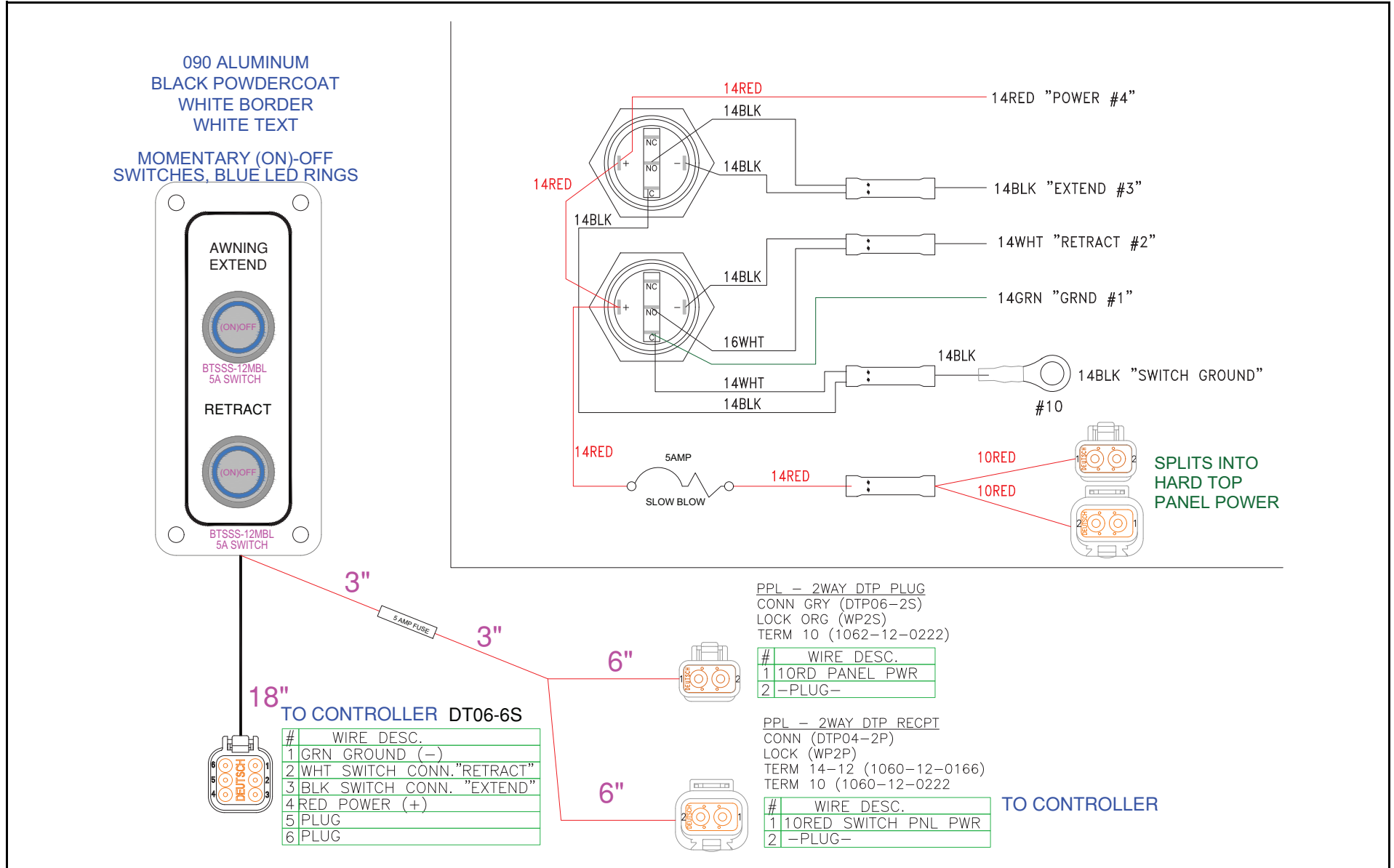





## MAIN ACC HARNESS - DECK (CON'T)

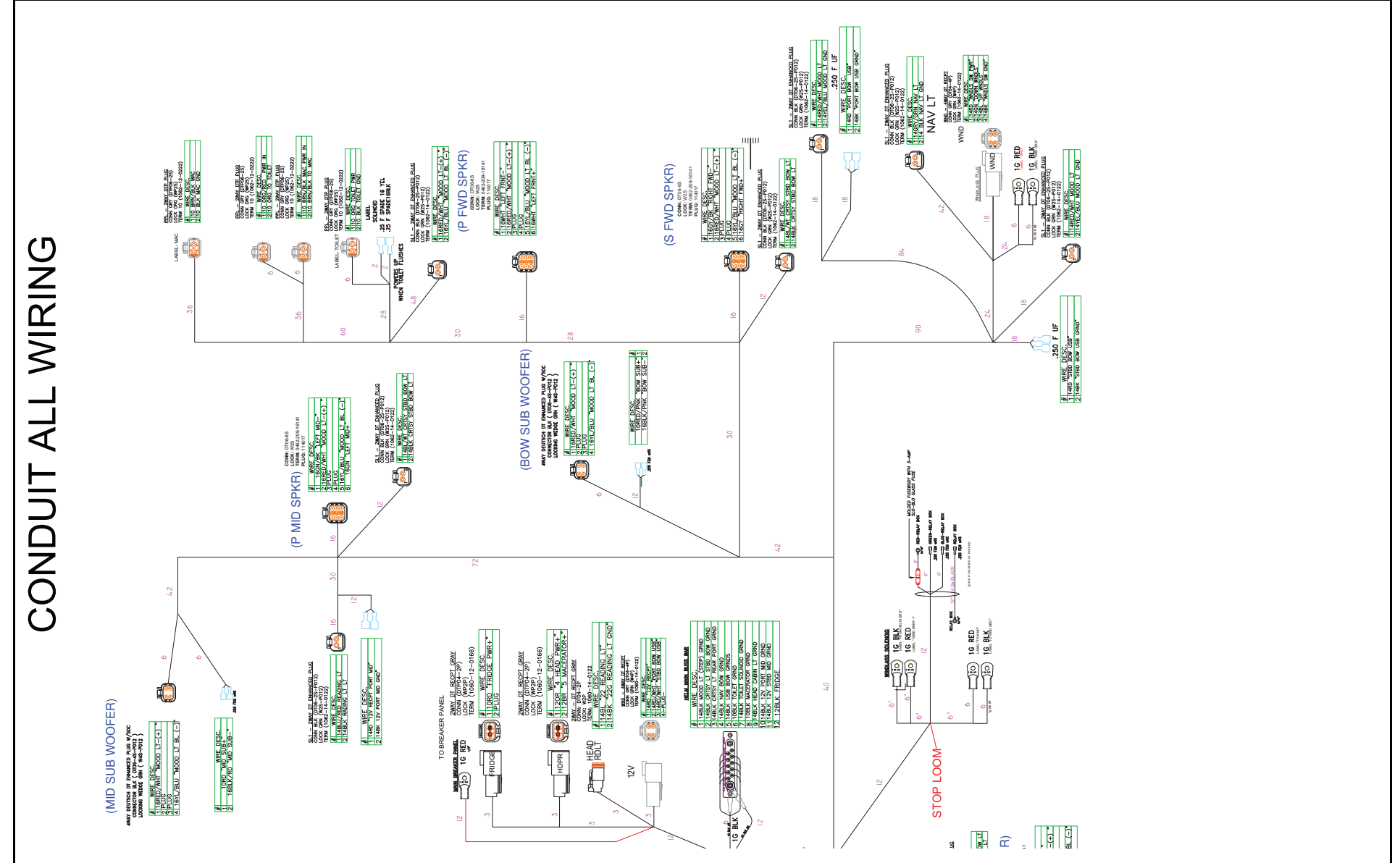





## AMPLIFIER ADAPTER KIT

ALL NON DEUTSCH CONNECTERS- HEAT SHRINK STYLE

### SUB WOOFER AMP- 600-1

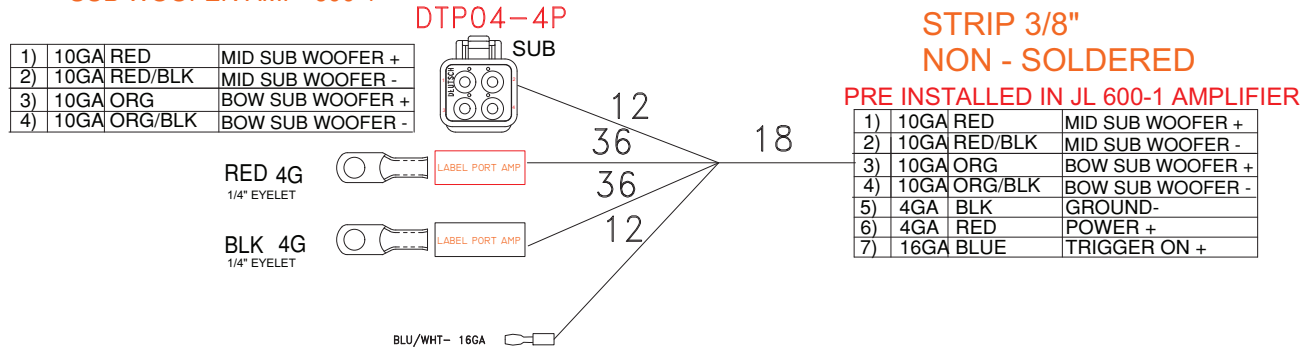

### SPEAKER AMP- 600-6

#### DECK PLUG (P) DT06-6S

1)	16GA WHITE	PT BOW SPK+
2)	16GA WHT/BLK	PT BOW SPK-
3)	16GA PINK	PT MID SPK+
4)	16GA PINK/BLK	PT MID SPK--
5)	16GA GREEN	PT AFT SPK+
6)	16GA GRN/BLK	PT AFT SPK--

#### DECK PLUG (SS) DT04-6P

1)	16GA GRAY	STBD BOW SPK+
2)	16GA GRY/BLK	STBD BOW SPK-
3)	16GA YELLOW	STBD MID SPK+
4)	16GA YEL/BLK	STBD MID SPK--
5)	16GA PURPLE	STBD AFT SPK+
6)	16GA PUR/BLK	STBD AFT SPK--

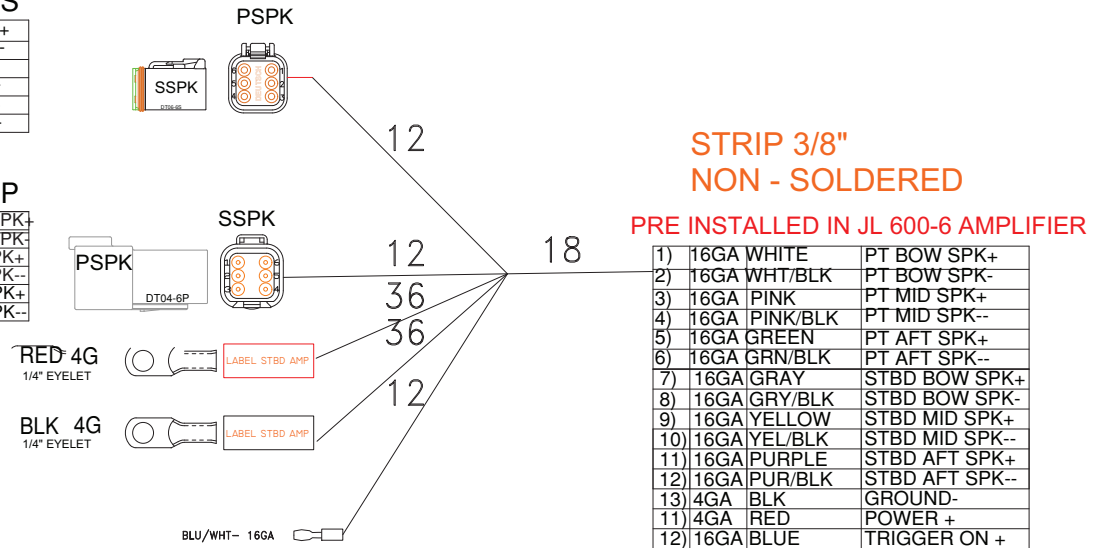

## STOVE - 120V AC PANEL

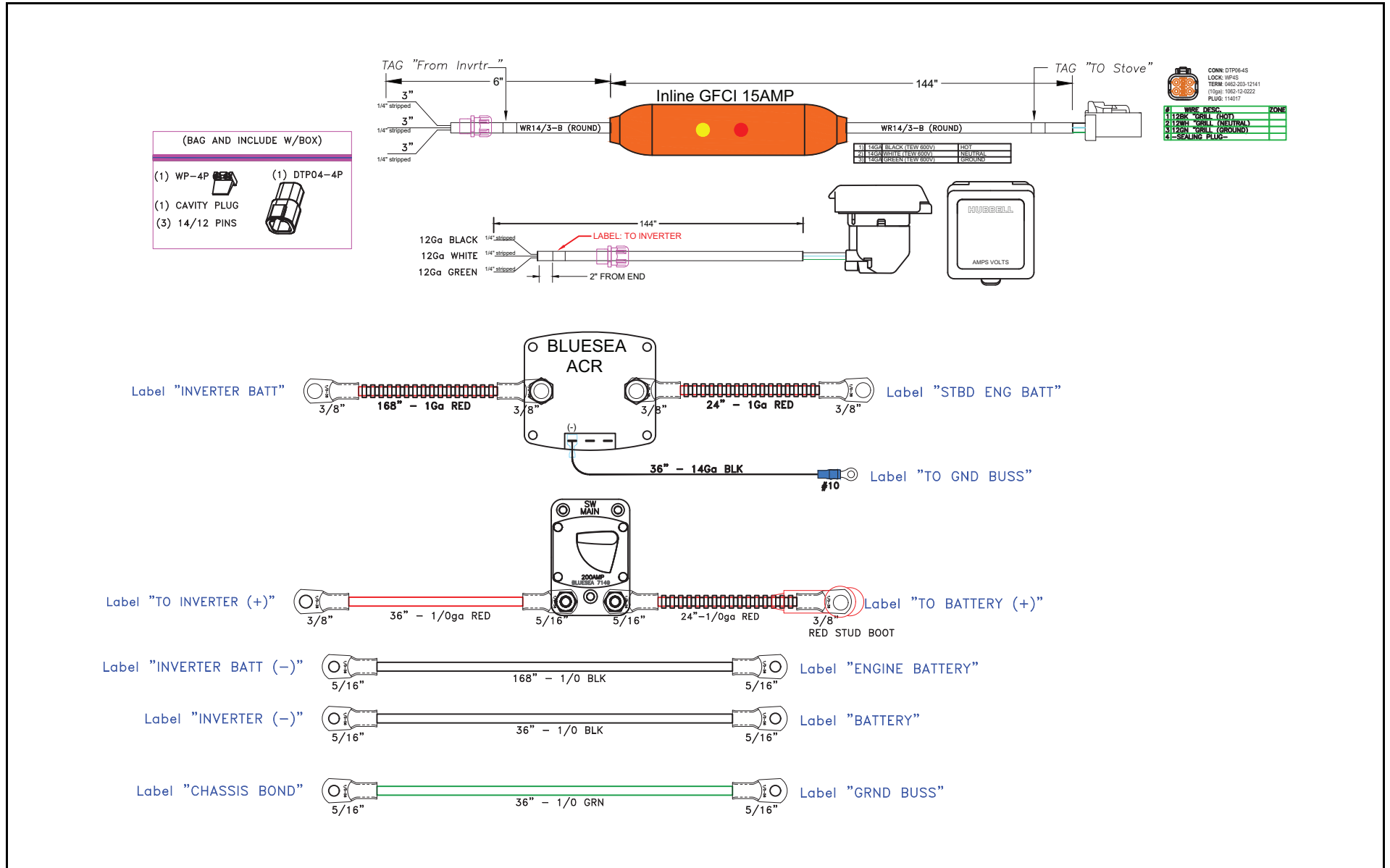

This Page Intentionally Left Blank



# SEA FOX

BOAT WORKS

**Sea Fox Boat Company, Inc.**  
2550 Highway 52  
Moncks Corner, SC 29461-5024

Telephone: 843-761-6090  
[www.seafoxboats.com](http://www.seafoxboats.com)

Ken Cook Co.  
Printed in U.S.A.  
Rev 1223