

268T



Owner's Manual Supplement

www.seafoxboats.com

SEA FOX BOAT'S DISCLAIMER

The following Owner's Manual is provided for information and educational purposes only and is not intended to offer or provide legal advice or create a contractual relationship between Sea Fox Boat Company and the owner of any Sea Fox brand vessel. Please beware that as a vessel owner you have non-delegable responsibilities regarding the safety, maintenance, fitness, and operation of your vessel and the extent of such responsibilities is ultimately determined by Federal law and regulations, the general maritime law of the United States, the laws and regulations of the states and territories of the United States, or the laws and regulations of the country where you operate your vessel. To fully understand your responsibilities as a vessel owner, and before operating or letting any third-party operate your vessel, we recommend that you consult the services of a qualified lawyer in admiralty and maritime law.

TABLE OF CONTENTS

Introduction	3	Electrical Schematics	15
Specifications	3	Main ACC Harness	15
Designated Occupant Seating	4	Main ACC Harness (Cont.)	16
Safety Decals.	5	Hardtop Harness.	17
Plumbing Schematics	7	Starboard Leg Harness.	18
Traveler Bilge Pumps.	7	Hardtop Panel.	19
Traveler Drains.	8	Mood/Underwater Light Harness	20
Traveler Waste System	9	Yamaha Twin Engine 12V Battery	21
Traveler Fresh Water System	10	Main Breaker Panel.	22
Traveler Raw Water System	11	Cooktop/Inverter System – AC Power Distribution	23
Traveler Livewell System	12	Cooktop/Inverter System – DC Power to Inverter	24
Traveler Fuel System	13	Helm Switch Panel	25
Traveler Power Steering System	14	Waste Discharge.	26
		Retractable Awning System	27

This Page Intentionally Left Blank

INTRODUCTION

Congratulations and Welcome Aboard! With so many boat brands to choose from, we want to congratulate you on your decision to choose Sea Fox Boats. For more than 24 years, Sea Fox offers the finest hand-crafted saltwater boats carefully balanced with the build-quality, features, styling and performance for the fairest price. Our passion for boating is evident in every model we make and we appreciate that you've noticed the Sea Fox difference.

We share your love for the moments spent on the water with friends and family, which is why every Sea Fox boat offers a unique blend of fishing/family options, technologies and innovative features. Your choice of a Sea Fox affirms that you have performed your research and compared the value of your model with the competition.

Whether you are new to the boating lifestyle or an old salt, we ask that **you and all other operators** read the owner's manual, this supplement, and all other literature provided with the boat **before** operating the boat or any equipment. We also recommend that all operators enroll in a boating safety course available online - see References and Contact Information in this section for education resources online.

This supplement contains model-specific information not included with the owner's manual. This manual is not intended to be a replacement for specific product literature provided by engine, accessory or other major equipment manufacturers, but rather to supplement that information.

Because of our philosophy of continuous product improvement, this manual serves as a general guide only, so the specifications and illustrations used may not match the equipment on your boat and are intended only as general reference views.

We welcome you to the Sea Fox family and wish you many years of boating enjoyment!

SPECIFICATIONS

Max. Weight Capacity	Yacht Certification
Persons	Yacht Certification
Persons Weight	Yacht Certification
Max. HP	425 hp (317 kw)
L.O.A.	26' (7.9 m)
Beam	9' 3" (2.8 m)
Draft	16 in. (0.41 m)
Height, Keel to Top (Light Folded)	117 in. (2.97 m)
Bridge Clearance Hard Top	101 in. (2.57 m)
Max. Weight Boat (w/ Options, Fluids, Largest HP)	8350 lbs (3787 kg)
Fuel Tank Capacity	140 gal (530 L)
Freshwater Tank Capacity	12 gal (45 L)
Holding Tank Capacity	6 gal (23 L)

DESIGNATED OCCUPANT SEATING

Be sure all passengers are properly seated in designated seating positions and not riding on the bow, bow pulpit, deck, gunwale or rear sun deck while underway. Passengers must use hand-holds and use caution when riding in the bow. Move to the aft passenger seats during rough water operation or if visibility is restricted.

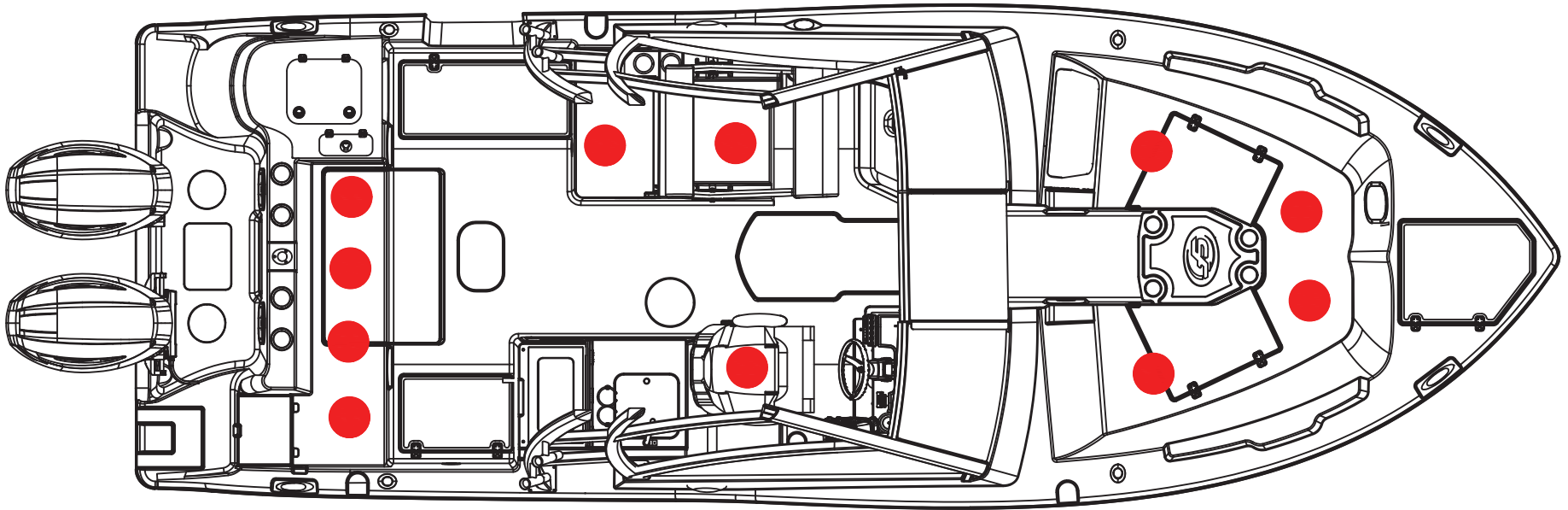

● = Seat position

SFOX-0085

SAFETY DECALS

5 FRESH WATER

9 FRESH WATER

9 RAW WATER

Manufactured by
SEA FOX
BOAT WORKS

WARNING
Moving parts can crush and cut. Keep hands clear while operating bracket. U36076-01

WARNING
Moving parts can crush and cut. Keep hands clear while operating bracket. U36076-01

WARNING
Moving parts can crush and cut. Keep hands clear while operating bracket. U36076-01

PROTECTED DESIGN
SEA FOX
BOAT WORKS
U.S. LIBRARY OF CONGRESS

AMERICAN BOAT & YACHT COUNCIL
ABYC
Boating Safety... Built In
www.abyc.org
MEMBER

WARNING
Failure to follow these warnings could cause severe injury or death.
• WEAR SAFETY LANYARD at all times while operating boat to prevent unattended boat operation.
• NEVER OPERATE WHILE UNDER THE INFLUENCE of drugs or alcohol.
• DO NOT OVERLOAD THE BOAT. ENSURE THAT WEIGHT IS PROPERLY AND EVENLY DISTRIBUTED fore and aft and on both sides of the boat to avoid poor handling sudden loss of control, swamping and/or capsizing.
• PASSENGERS SHOULD WEAR U.S. COAST GUARD APPROVED LIFE JACKETS.
• MAKE SURE THAT ALL PASSENGERS ARE PROPERLY SEATED WHILE UNDERWAY. To avoid passengers falling overboard or being ejected from the boat, do not allow passengers to sit on seat backs, gunwales or outermost deck edges while boat is moving.
• REDUCE SPEED BEFORE ATTEMPTING SUDDEN OR SHARP TURNS.
• AND MAINTAIN SAFE SPEEDS for water conditions and environment at all times. Maneuverability at high speeds is limited, and sudden turns may cause loss of boat control.
• KEEP PROPER LOOKOUT AND SAFE DISTANCE for the conditions at all times to avoid collisions.
• OBEY APPLICABLE NAVIGATION RULES AND BOATING LAWS.
• USE CAUTION AND PROPER LIGHTING during nighttime boating and boating in adverse weather.
• READ THE OWNER'S MANUAL AND COMPLETE THE BOATER'S PRE-OPERATION CHECKLIST prior to boat operation. U40620-01

DANGER
Operating, servicing and maintaining a recreational marine vessel can expose you to chemicals including engine exhaust, carbon monoxide, phthalates, and lead, which are known to the State of California to cause cancer and birth defects or other reproductive harm. To minimize exposure, avoid breathing exhaust, service your vessel in a well-ventilated area and wear gloves or wash your hands frequently when servicing this vessel. For more information go to www.P65warnings.ca.gov/marine. U36438-01

DANGER
Carbon monoxide (CO) can cause brain damage or death.
Engine and generator exhaust contains odorless and colorless carbon monoxide gas.
Carbon monoxide will be around the back of the boat when engines or generators are running.
Move to fresh air, if you feel nausea, headache, dizziness, or drowsiness. U36088-01

DANGER
HOT GRILL SURFACE MAY CAUSE SEVERE BURNS.
WHEN THE GRILL IS POWERED ON, THE SURFACE WILL BE HOT.
TURN THE POWER OFF AND ALLOW THE GRILL SURFACE TO COOL BEFORE TOUCHING OR CLEANING.
WARNING
COVERING A HOT GRILL SURFACE AND NOT PROPERLY CLEANING THE DRIP TRAY COULD CAUSE A FIRE HAZARD.
GRILL COUNTERTOP COVER MAY MELT OR CATCH FIRE IF EXPOSED TO HIGH HEAT FROM THE GRILL.
TURN OFF THE GRILL AND ALLOW THE SURFACE TO COOL BEFORE COVERING AND/OR OPERATING THIS VESSEL.
CLEAN DRIP TRAY AFTER EACH USE. U36030-01

WARNING
CONTENTS CAN BE UNDER PRESSURE. AVOID SERIOUS INJURY OR DEATH FROM FIRE OR EXPLOSION. OPEN SLOWLY IN WELL VENTILATED AREA. NO SMOKING OR OPEN FLAMES. U36088-01

WARNING
YACHT CERTIFICATION
THIS BOAT COMPLIES WITH THE U.S. COAST GUARD SAFETY STANDARDS IN EFFECT ON THE DATE OF CERTIFICATION
SEA FOX BOAT COMPANY
MONCKS CORNER, S.C.

WARNING
Do not stand on or jump off of lounge footrest.
Watch your hands and fingers when opening and closing cover.
Maximum seated weight capacity 250 lbs. U40627-01

WARNING
PINCH POINT
Watch your hands and fingers when opening and closing cover.
AVOID PERSONAL INJURY SECURE GATE/DOOR WHEN BOAT IS UNDERWAY. ENSURE LADDER IS SECURED TO DECK PRIOR TO USING IF EQUIPPED. U36072-01

WARNING
Failure to follow these warnings could cause SERIOUS INJURY or DEATH.
• REMAIN PROPERLY SEATED AND HOLD ON to available handrails while boat is moving to avoid falling overboard or being ejected from the boat. Do not sit on seat backs, gunwales or outermost deck edges.
• WEAR U.S. COAST GUARD APPROVED LIFE JACKETS.
• DO NOT OVERLOAD THE BOAT. OCCUPANTS AND GEAR MUST BE PROPERLY AND EVENLY DISTRIBUTED fore and aft, and on both sides of the boat. Improper loading and/or overloading may result in poor handling, sudden loss of control, swamping and/or capsizing.
• REFER TO AND OBEY THE DESIGNATED OCCUPANT SEATING POSITIONS that are indicated by the manufacturer for your specific model.
• OBEY THE OPERATOR at all times.
• DO NOT RESTRICT THE OPERATOR'S VISION.
• DO NOT DEPART THE VESSEL without informing the operator.

BATTERY CHARGER U36042-01

INVERTER CHARGER -STOVE U40625-01

NOTICE
SHUT OFF VALVE(S) LOCATED BEHIND ACCESS PANEL. CLOSE VALVE(S) WHEN NOT IN USE. U36042-01

NOTICE
SHUT OFF VALVE(S) LOCATED BEHIND ACCESS PANEL. CLOSE VALVE(S) WHEN NOT IN USE. U36042-01

NOTICE
SHUT OFF VALVE(S) LOCATED BEHIND ACCESS PANEL. CLOSE VALVE(S) WHEN NOT IN USE. U36042-01

NOTICE
THIS BOAT IS EQUIPPED WITH AN OPTIONAL DIRECT OVERBOARD DISCHARGE VALVE. DISCHARGING OF SEWAGE DIRECTLY OVERBOARD IS FOR USE WHERE APPROVED ONLY. U36042-01

NON POTABLE WATER U36077-01

NON POTABLE WATER U36077-01

FIRST AID KIT INSIDE U36042-01

NO WOOD! NO ROT! U36042-01

WARNING
Leaking fuel is a fire and explosion hazard.
Avoid serious injury or death from fire or explosion from leaking fuel. Inspect system for leaks at least once a year. U36042-01

WARNING
It is illegal for any vessel to dump plastic ANYWHERE in the ocean or navigable waters of the United States. Annex V of MARPOL TREATY is an International Law for a cleaner, safer marine environment. Violation of these requirements is a Class D Felony and may result in a civil penalty, up to \$25,000 fine and imprisonment.

U.S. lakes, rivers, bays or sounds and 3 miles from shore	3 to 12 miles	12 to 25 miles	Outside 25 miles
ILLEGAL TO DUMP: Plastic and Garbage	ILLEGAL TO DUMP: Plastic	ILLEGAL TO DUMP: Plastic	ILLEGAL TO DUMP: Plastic
Paper Rags Glass Food	Dunnage, lining and packing materials that float; also if not ground to less than one inch Paper Rags Metal Glass	Dunnage, lining and packing materials that float. Paper Crocery Rags Metal Food	

Regional state and local regulations may further restrict the disposal of garbage. The discharge of all garbage into the Great Lakes or their connecting or tributary waters is prohibited. U36042-01

WARNING
Rotating propeller may cause serious injury or death. Shut off engine when near persons in the water.
Carbon monoxide (CO) can cause brain damage or death. Engine and generator exhaust contains odorless and colorless carbon monoxide gas. Signs of carbon monoxide poisoning include nausea, headache, dizziness, drowsiness, and lack of consciousness. Get fresh air if anyone shows signs of carbon monoxide poisoning. See Owner's Manual for information regarding carbon monoxide poisoning.
Leaking fuel is a fire and explosion hazard. Avoid serious injury or death from fire or explosion from leaking fuel. Inspect system for leaks at least once a year. U36042-01

WARNING
CARBON MONOXIDE (CO) CAN CAUSE BRAIN DAMAGE OR DEATH.
-Carbon monoxide can be present in the cabin.
-Signs of carbon monoxide poisoning include nausea, headache, dizziness, drowsiness, and lack of consciousness.
MOVE TO FRESH AIR if anyone shows signs of carbon monoxide poisoning.
USE AVAILABLE HANDRAILS AND HANDHOLDS while moving about the cabin and while the boat is in motion to avoid falling. U40619-01

DANGER
ROTATING PROPELLER CAN CAUSE SERIOUS INJURY OR DEATH. SHUT OFF MOTOR WHEN NEAR PERSONS IN WATER. U36088-01

DANGER
ROTATING PROPELLER CAN CAUSE SERIOUS INJURY OR DEATH. SHUT OFF MOTOR WHEN NEAR PERSONS IN WATER. U36088-01

WARNING
AVOID PERSONAL INJURY SECURE GATE/DOOR & DO NOT BE OUTSIDE GATE/DOOR WHEN BOAT IS UNDERWAY. U36076-01

WARNING
AVOID PERSONAL INJURY LOCK/LATCH WIND DAM DOOR IN THE OPEN & CLOSED POSITION WHEN BOAT IS UNDERWAY. U40627-01

- 1= COCKPIT FRONT
- 2=CONSOLE
- 3= FUEL FILL
- 3= HEAD COMPARTMENT
- 4= COCKPIT MID SHIP PORT
- 5= GALLEY STBD
- 6= COCKPIT AFT
- 7= TRANSOM GATE
- 8= DIVE DOOR
- 9=TRASOM

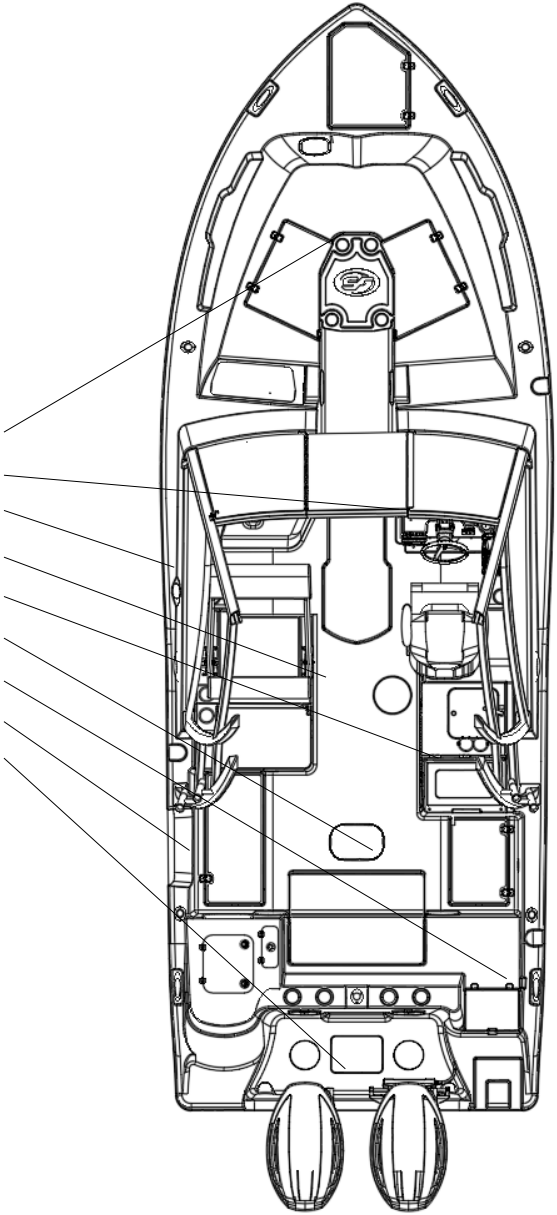

PLUMBING SCHEMATICS

TRAVELER BILGE PUMPS

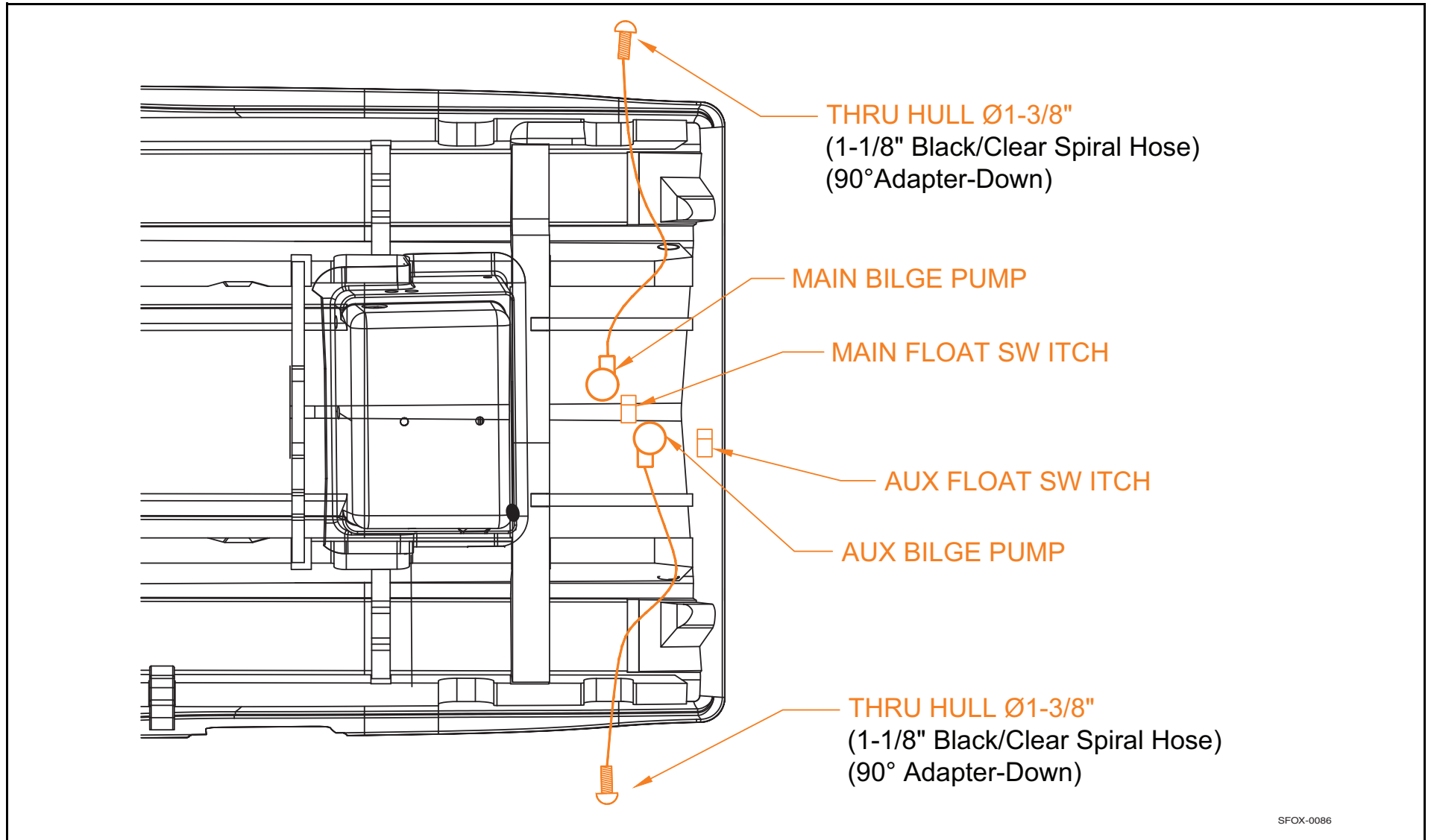

TRAVELER DRAINS

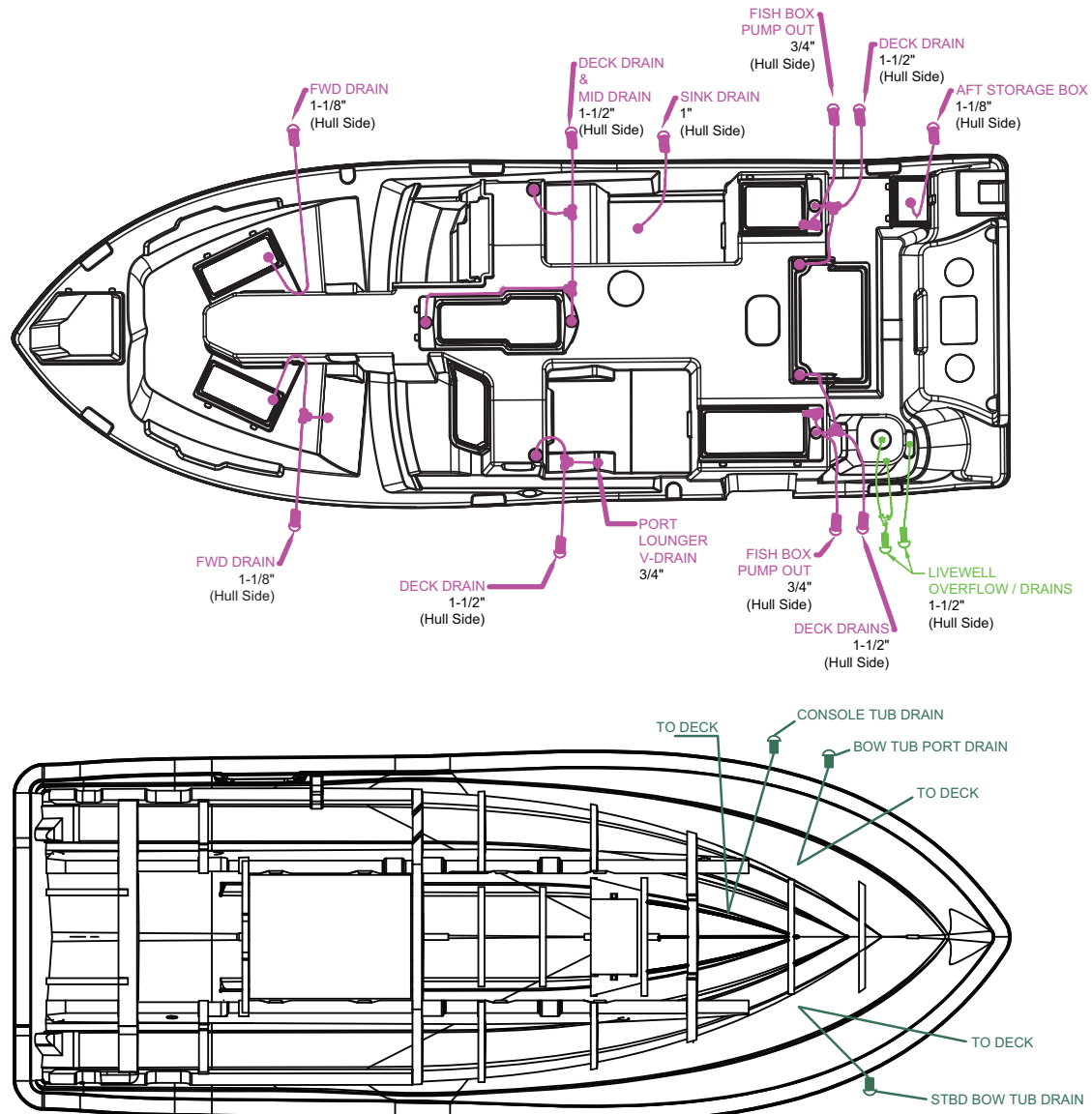

SFOX-0087

TRAVELER WASTE SYSTEM

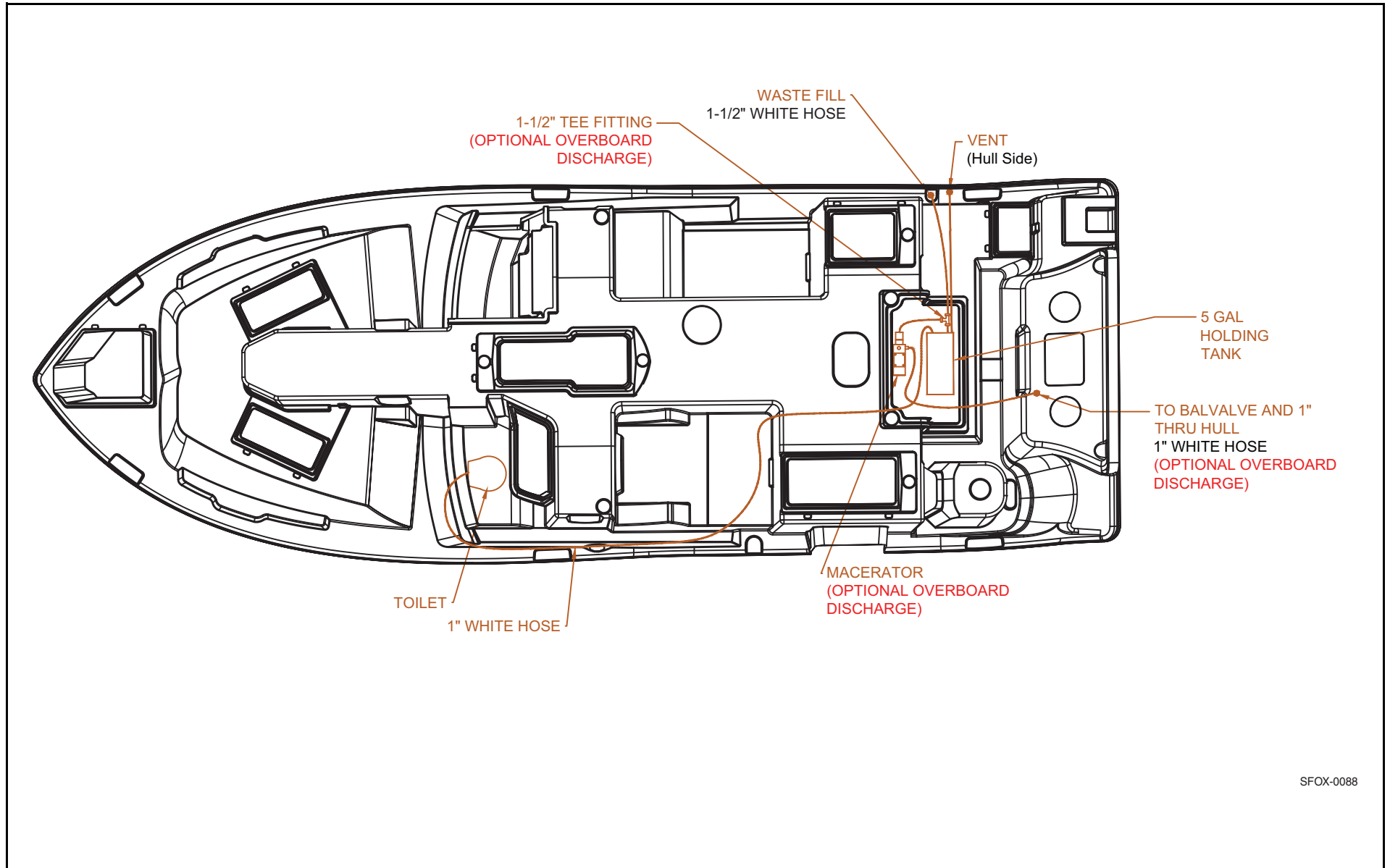

SFOX-0088

TRAVELER FRESH WATER SYSTEM

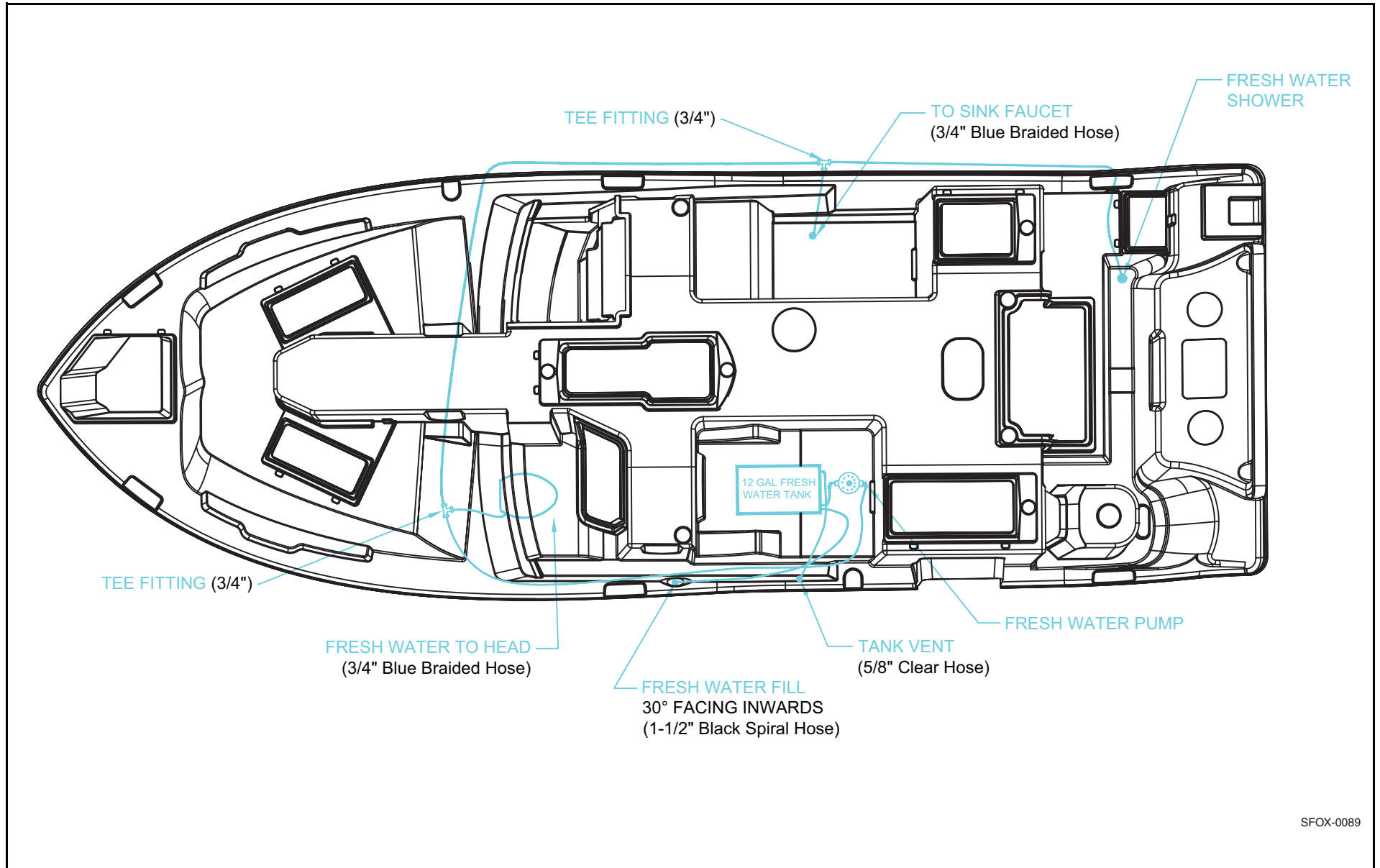

SFOX-0089

TRAVELER RAW WATER SYSTEM

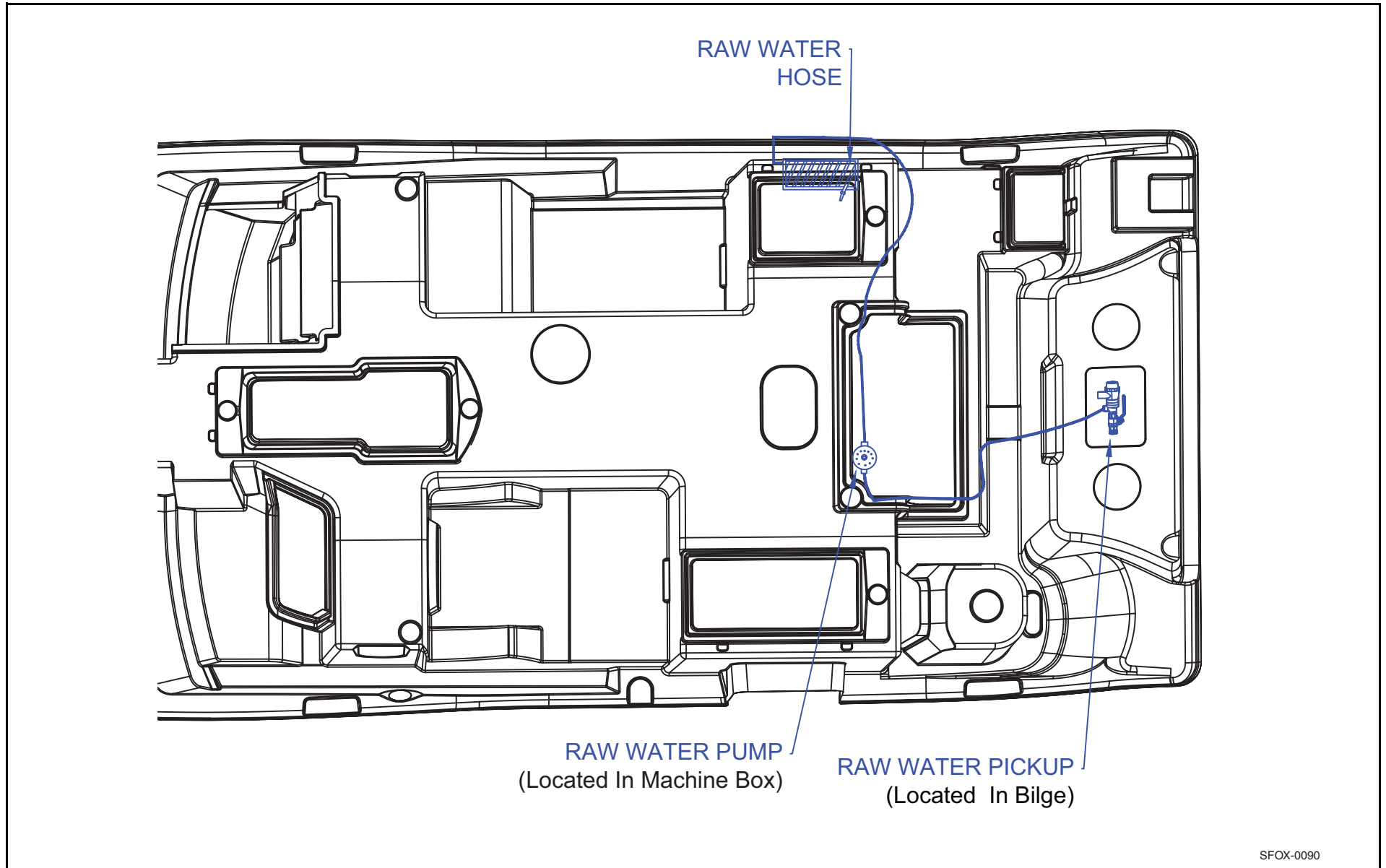

TRAVELER LIVEWELL SYSTEM

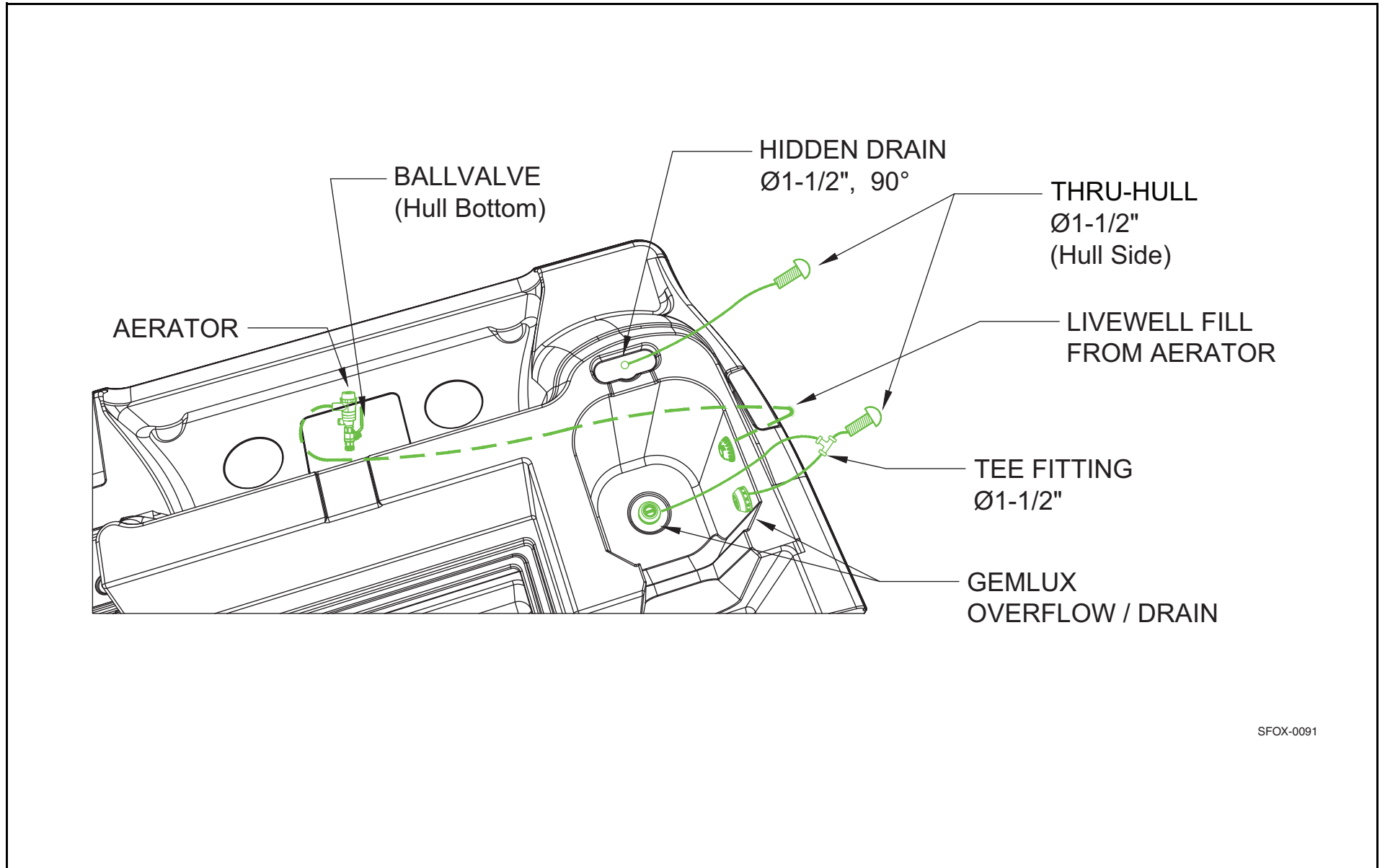

SFOX-0091

TRAVELER FUEL SYSTEM

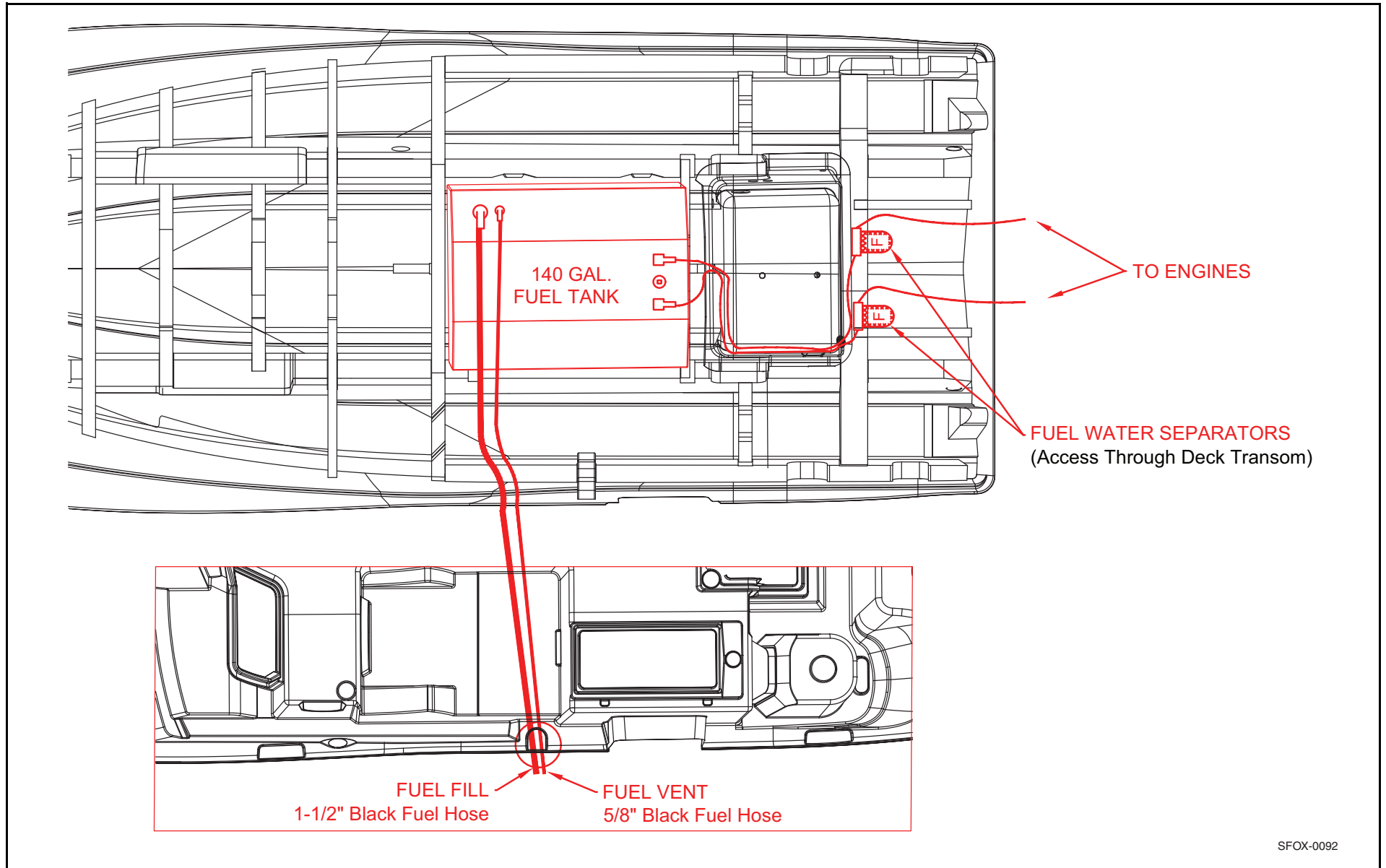

SFOX-0092

TRAVELER POWER STEERING SYSTEM

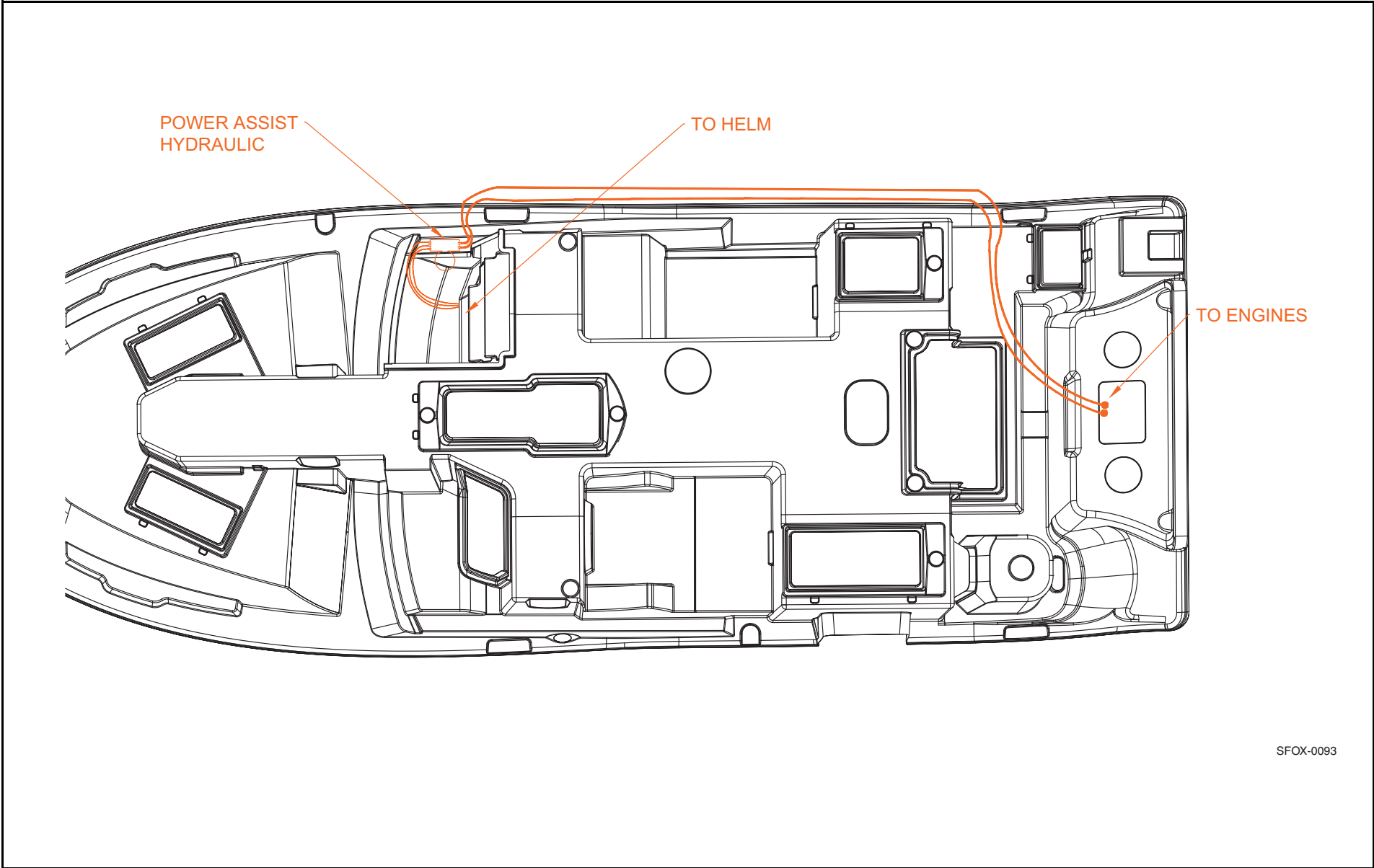

SFOX-0093

ELECTRICAL SCHEMATICS

MAIN ACC HARNESS

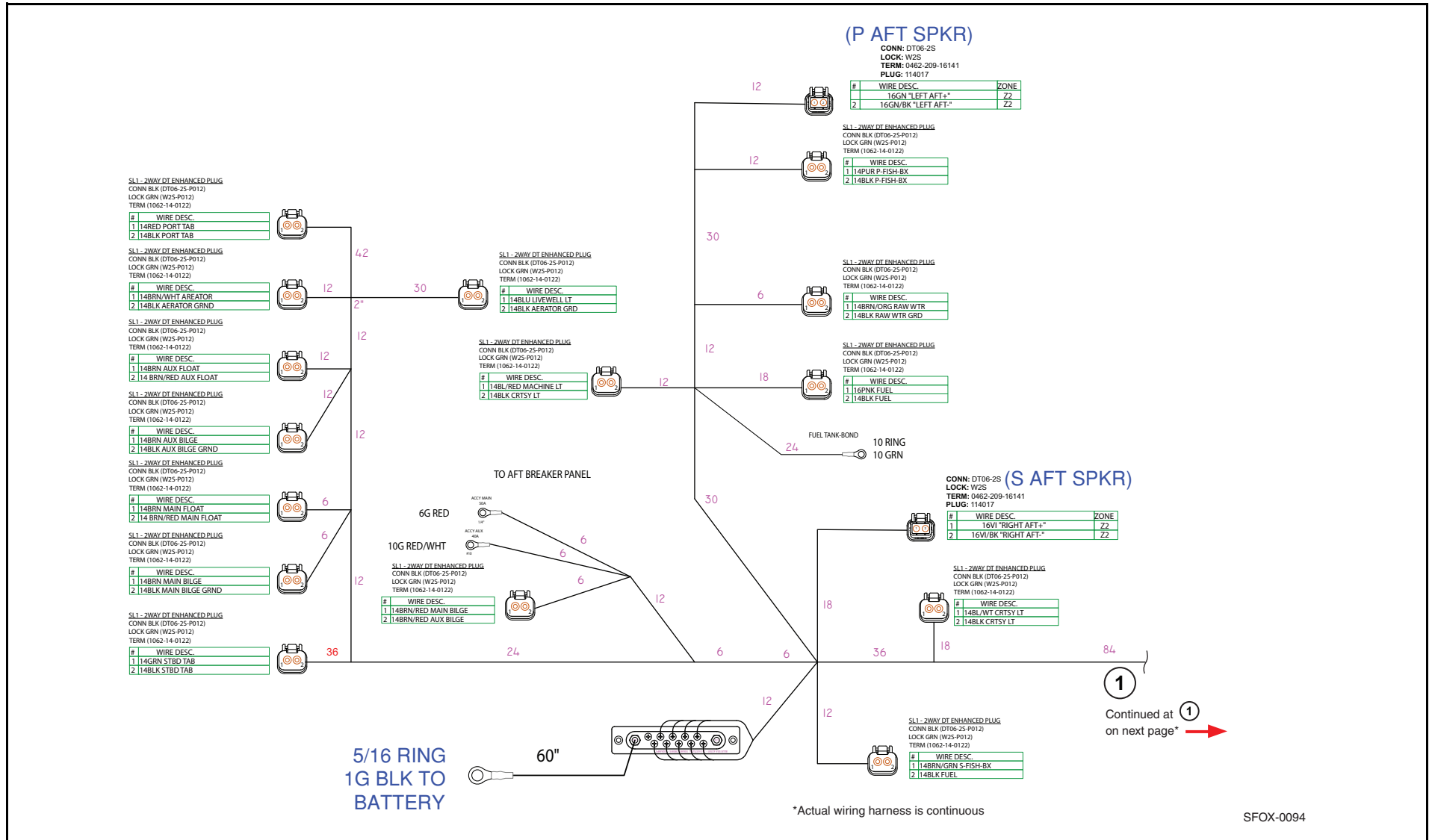

STARBOARD LEG HARNESS

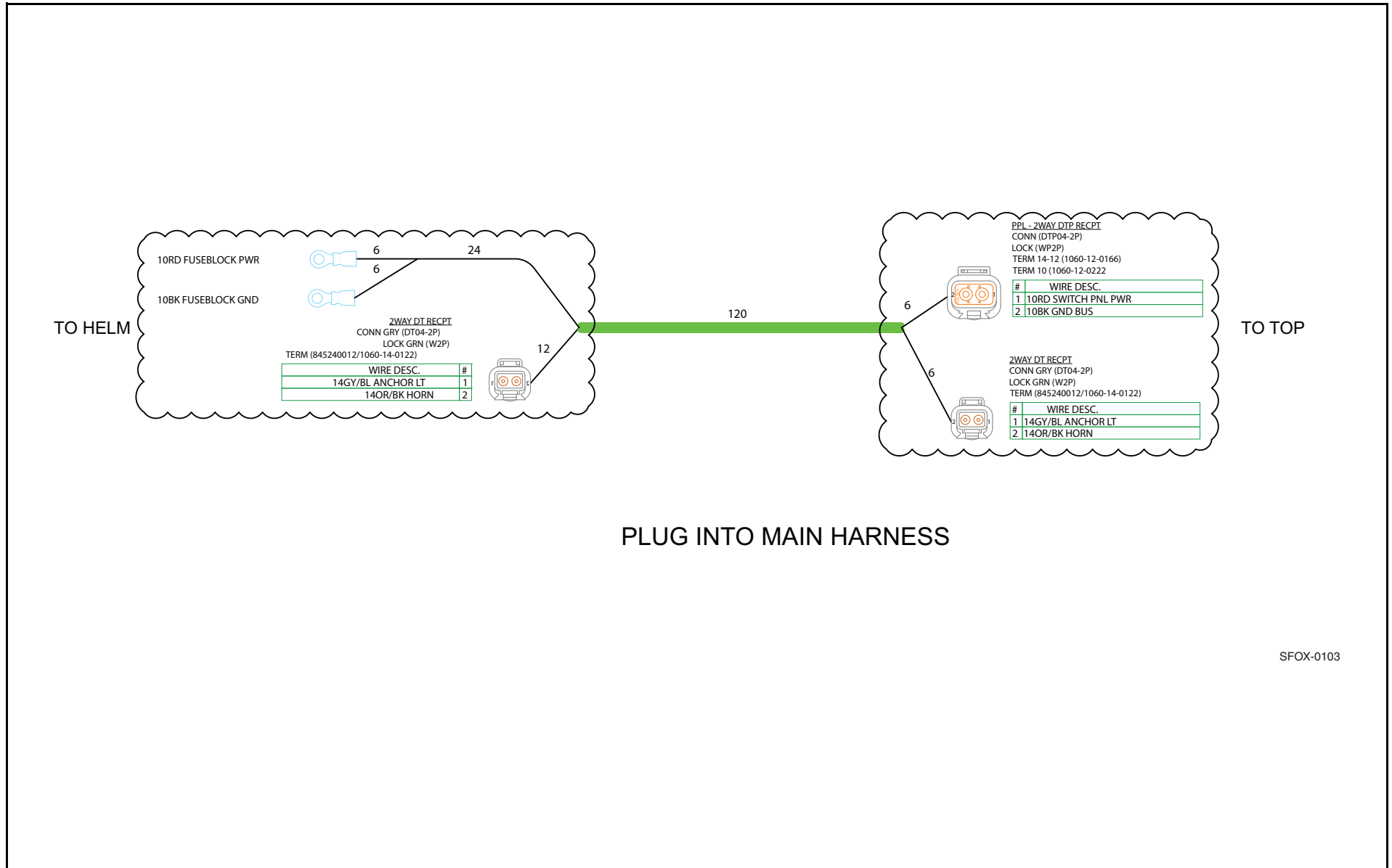

SFOX-0103

HARDTOP PANEL

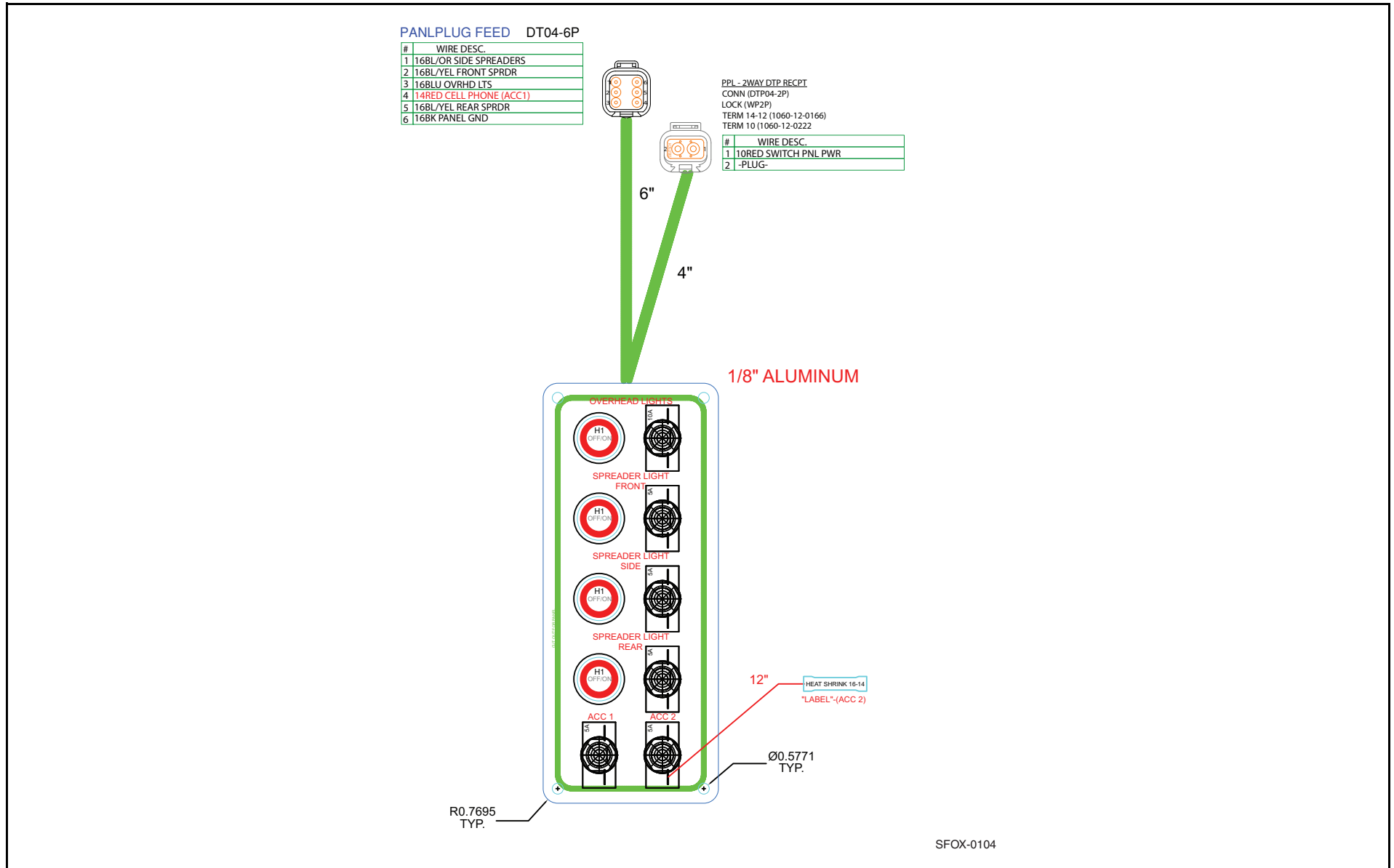

MOOD/UNDERWATER LIGHT HARNESS

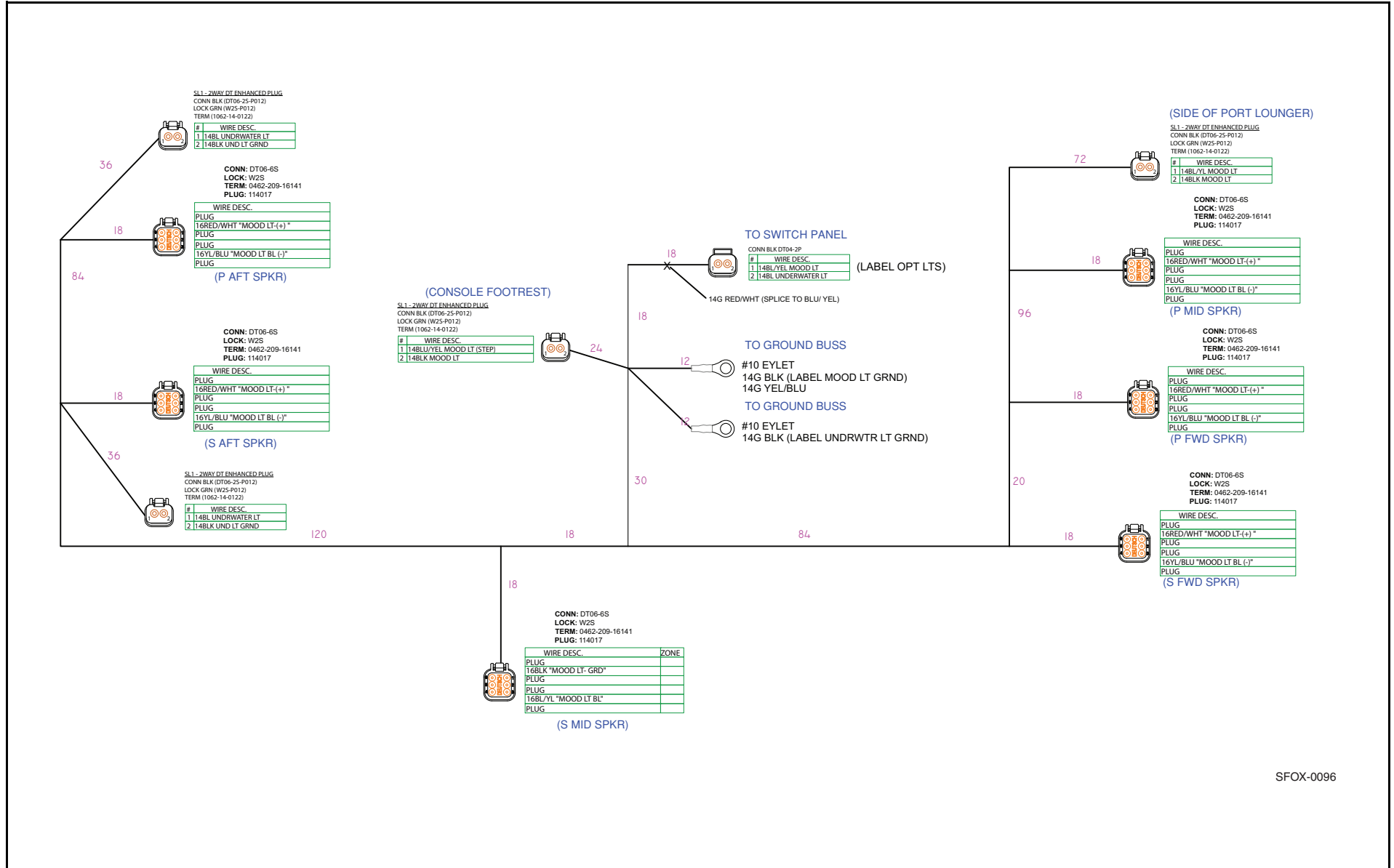

SFOX-0096

YAMAHA TWIN ENGINE 12V BATTERY

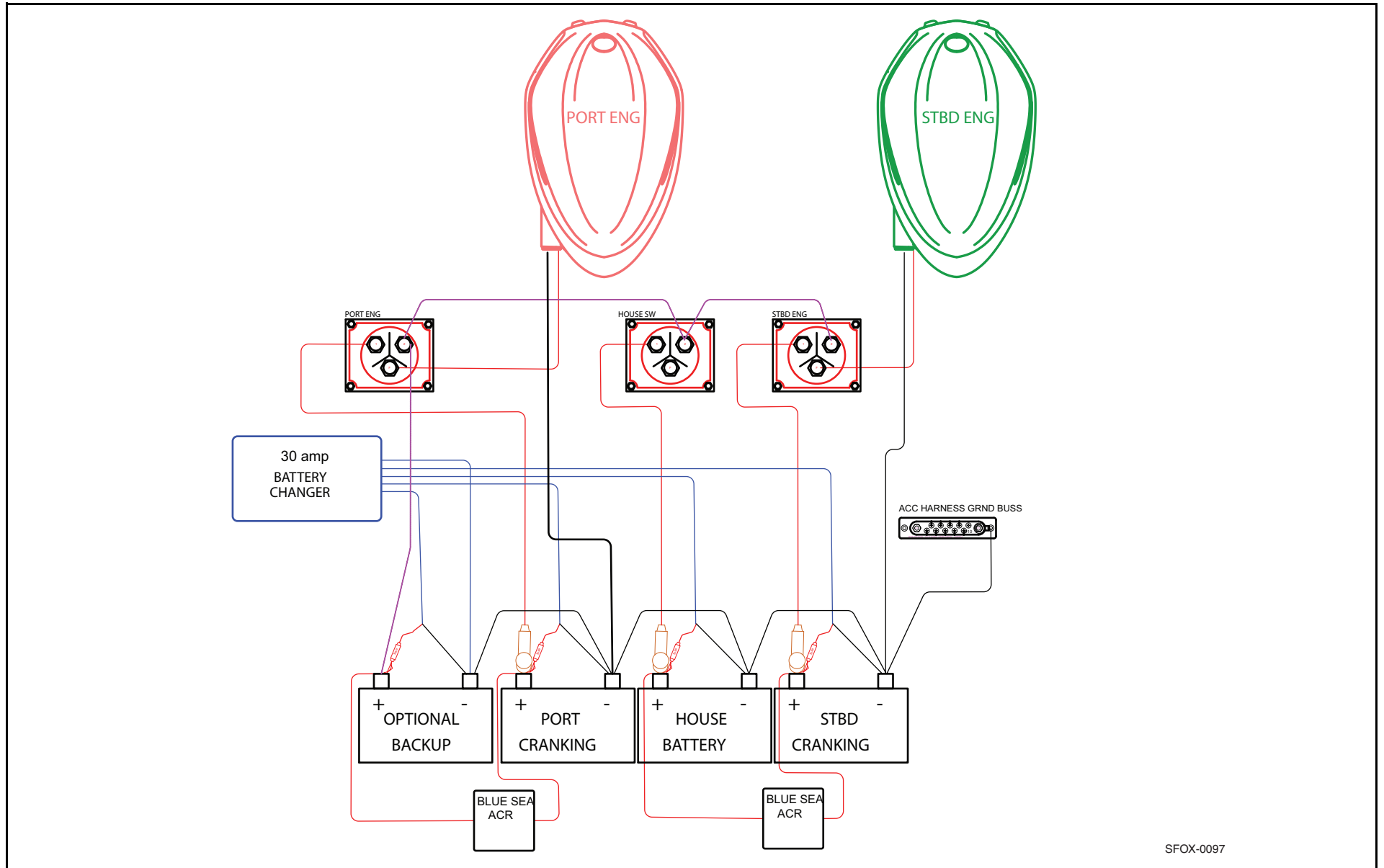

SFOX-0097

MAIN BREAKER PANEL

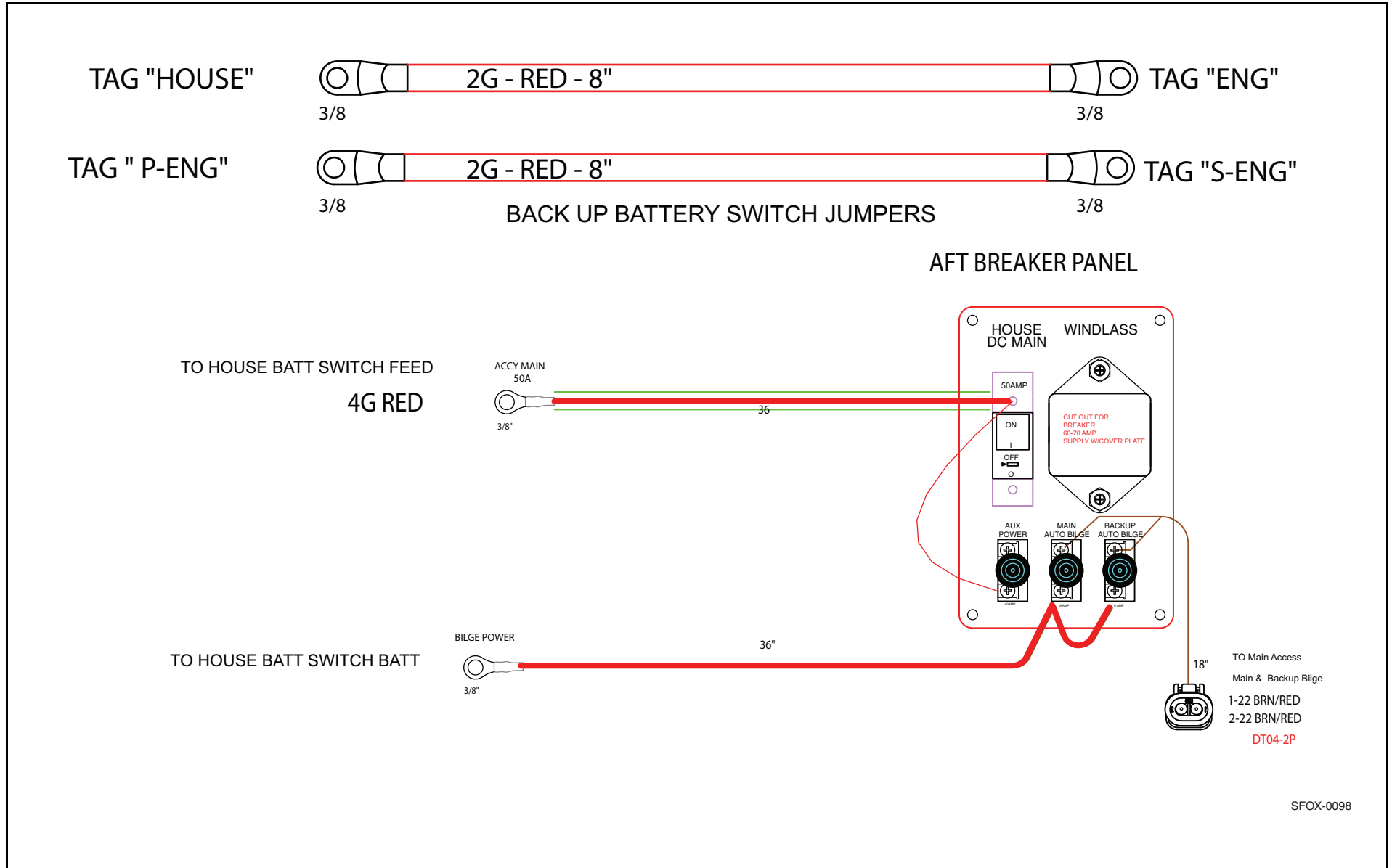

SFOX-0098

COOKTOP/INVERTER SYSTEM – AC POWER DISTRIBUTION

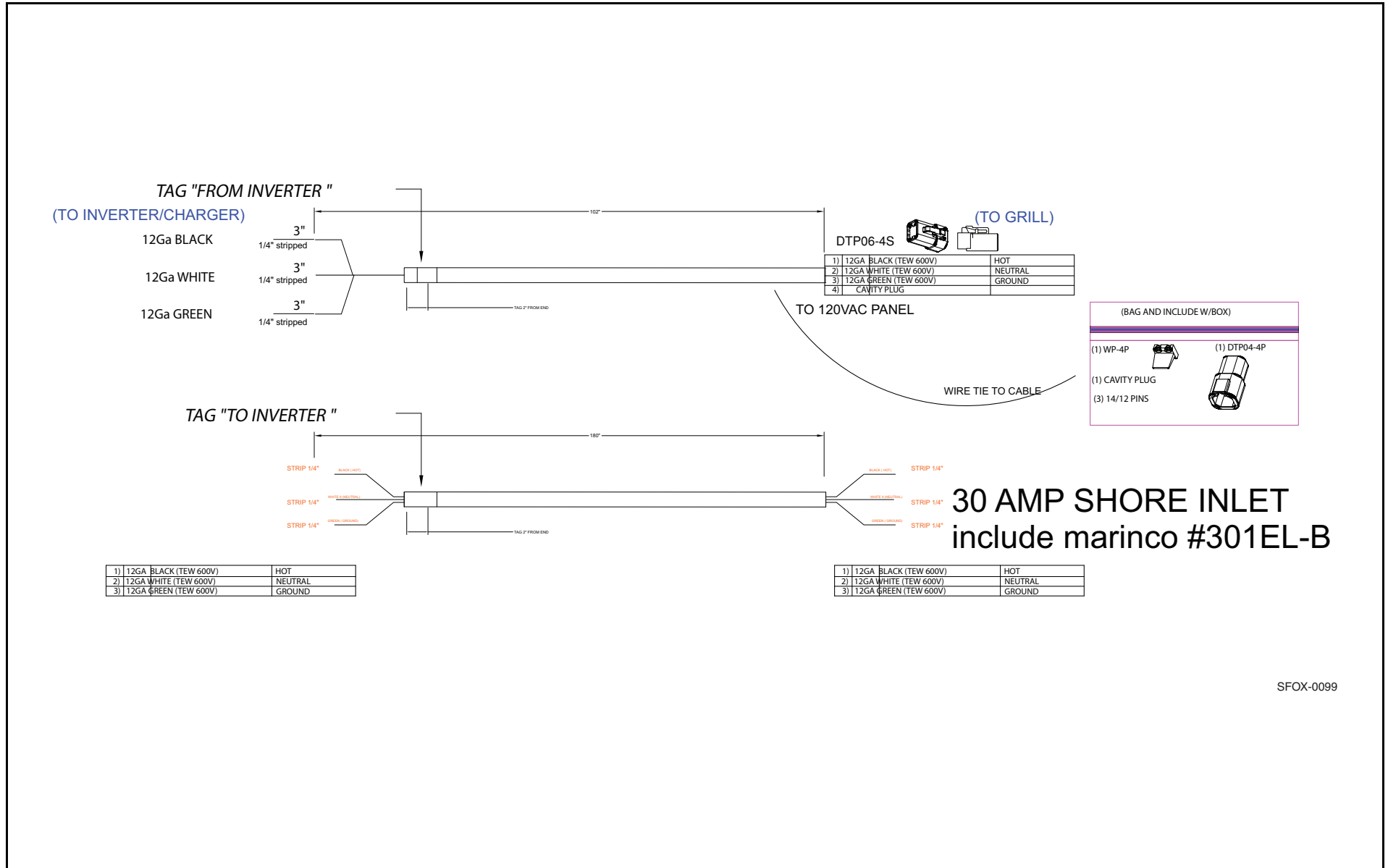

SFOX-0099

COOKTOP/INVERTER SYSTEM – DC POWER TO INVERTER

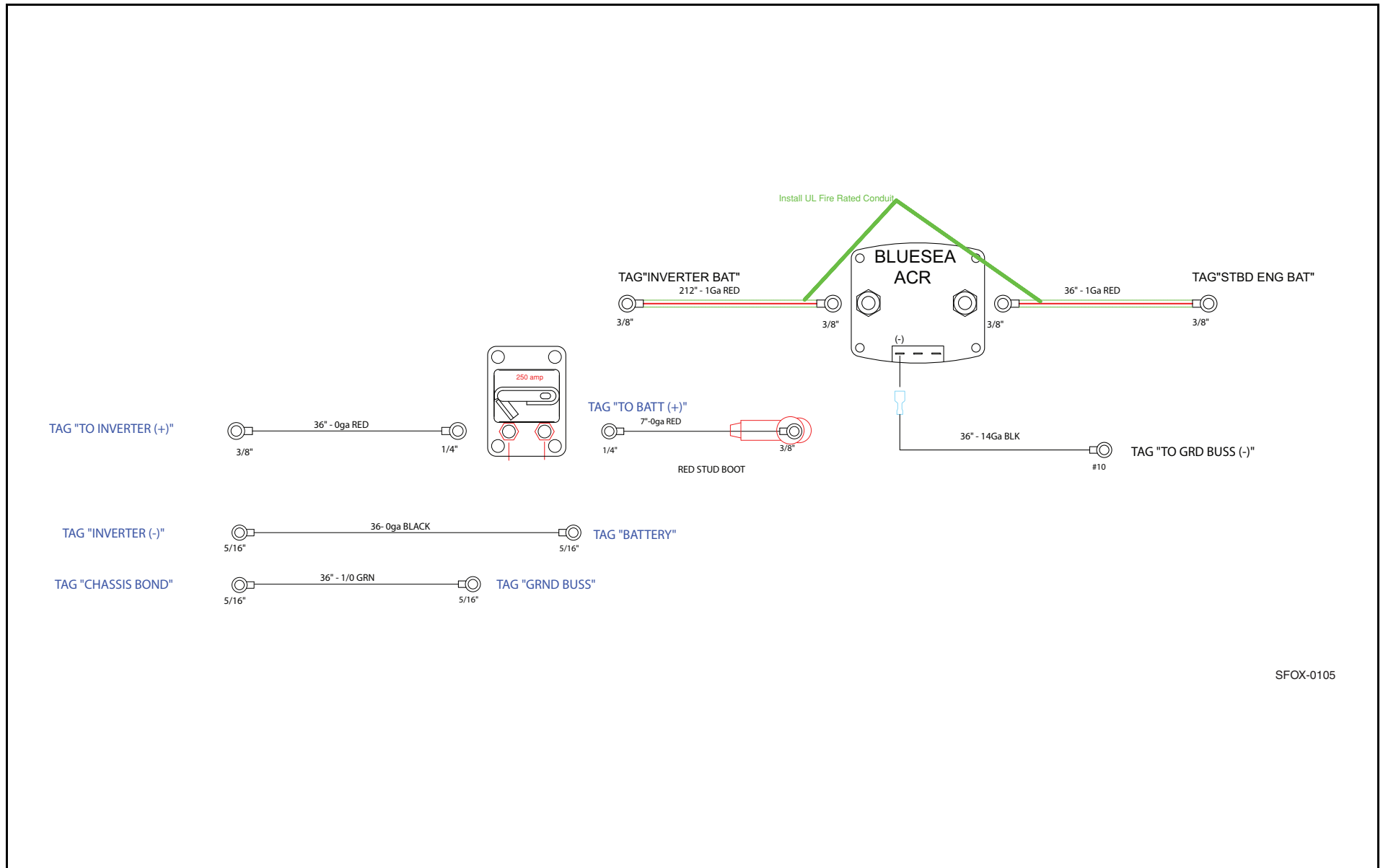

SFOX-0105

WASTE DISCHARGE

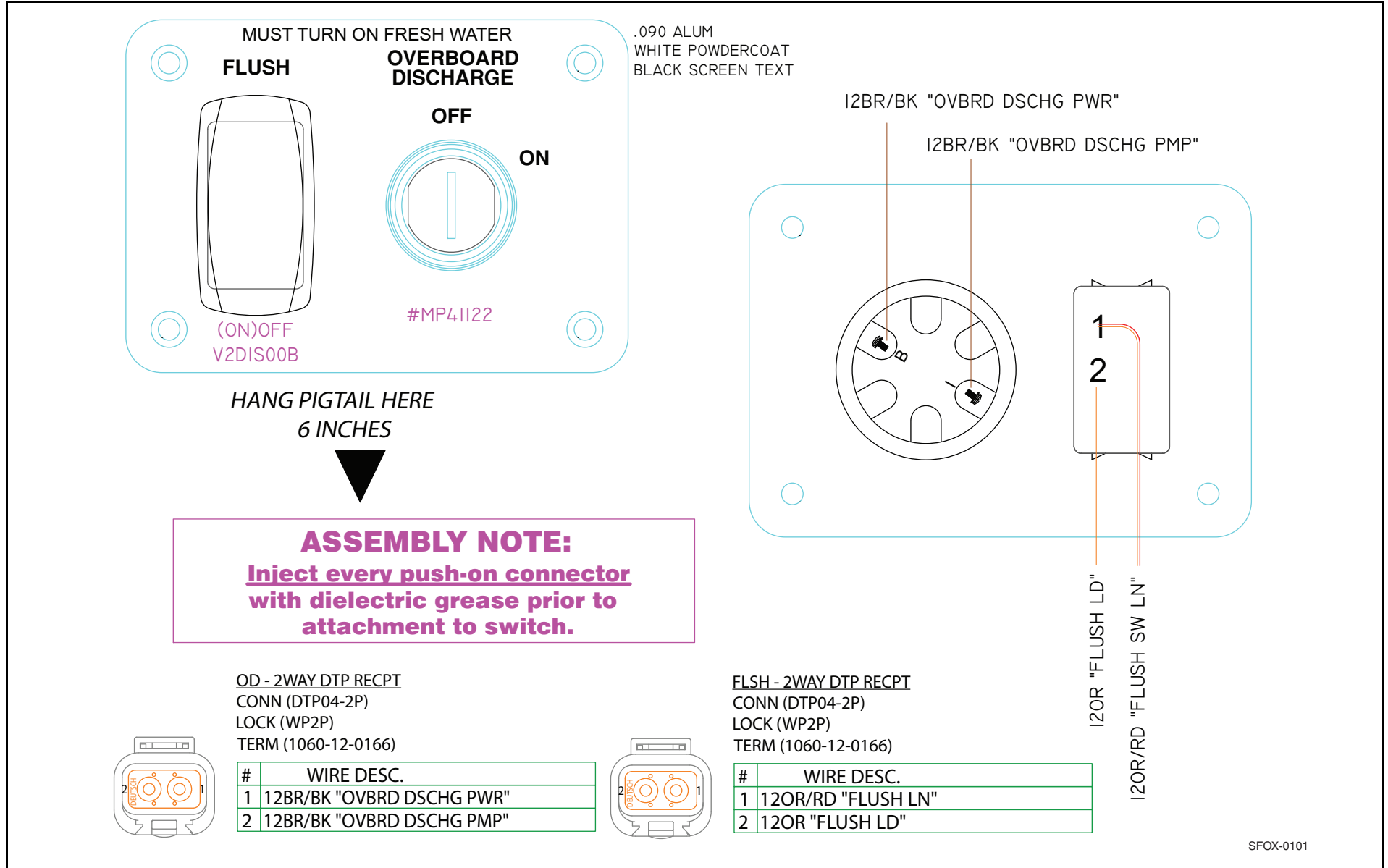

RETRACTABLE AWNING SYSTEM

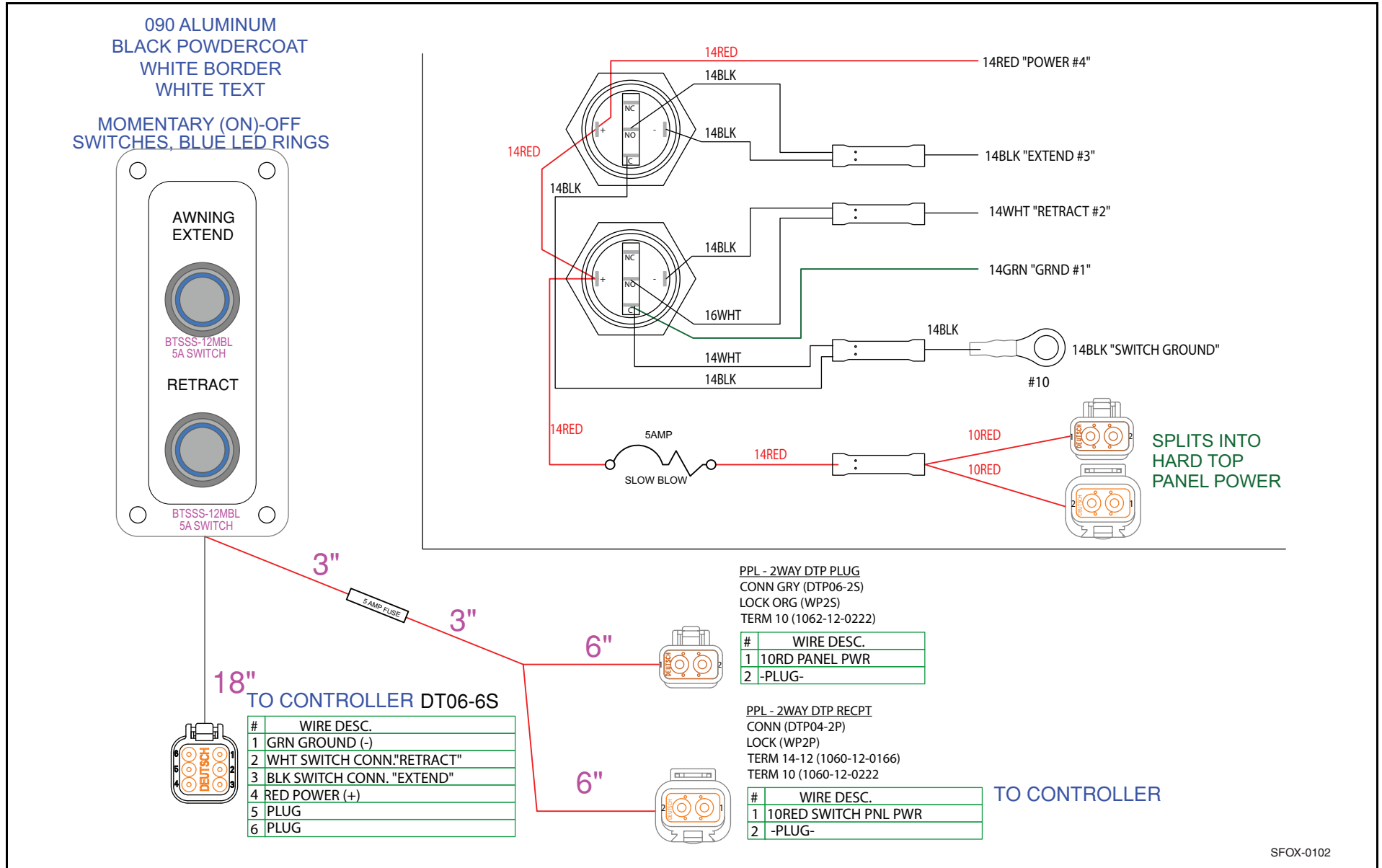

This Page Intentionally Left Blank

SEA  FOX
BOAT WORKS

Sea Fox Boat Company, Inc.
2550 Highway 52
Moncks Corner, SC 29461-5024

Telephone: 843-761-6090
www.seafoxboats.com

Ken Cook Co.
Printed in U.S.A.
Rev 0124