

368C



Owner's Manual Supplement

www.seafoxboats.com

SEA FOX BOAT'S DISCLAIMER

The following Owner's Manual is provided for information and educational purposes only and is not intended to offer or provide legal advice or create a contractual relationship between Sea Fox Boat Company and the owner of any Sea Fox brand vessel. Please beware that as a vessel owner you have non-delegable responsibilities regarding the safety, maintenance, fitness, and operation of your vessel and the extent of such responsibilities is ultimately determined by Federal law and regulations, the general maritime law of the United States, the laws and regulations of the states and territories of the United States, or the laws and regulations of the country where you operate your vessel. To fully understand your responsibilities as a vessel owner, and before operating or letting any third-party operate your vessel, we recommend that you consult the services of a qualified lawyer in admiralty and maritime law.

TABLE OF CONTENTS

Introduction	3	Harness, Hard Top Panel Kit 5 of 5	26
Specifications	3	Kit, Hard Top 1 of 3	27
Designated Occupant Seating	4	Kit, Hard Top 2 of 3	27
Safety Decals.	5	Kit, Hard Top 3 of 3	28
Plumbing Schematics	7	Panel, Main DC Distribution 1 of 2	29
Plumbing, Deck 1 of 2	7	Panel, Main DC Distribution 2 of 2	30
Plumbing, Deck 2 of 2	8	Cable Set, Triple Engine	31
Drains, Forward	9	Cable Set, Triple Engine	32
Drains, Aft	10	Cable Set, Twin Engine.	33
Drains, Bilge.	11	Panel, Generator, A/C, Charging Systems	34
Freshwater System, Hull	12	Panel, Generator, Shore Power, A/C, Charging Systems 1 of 2	35
Freshwater System, Deck	13	Panel, Generator, Shore Power, A/C, Charging Systems 2 of 2	36
Raw Water System	14	Panel, Shore Power, A/C, Charging Systems 1 of 3	37
Waste Water System	15	Panel, Shore Power, A/C, Charging Systems 2 of 3	38
Fuel System, Gasoline.	16	Panel, Shore Power, A/C, Charging Systems 3 of 3	39
Fuel System, Diesel	17	Panel Kit, Seakeeper 3	40
Electrical Schematics	18	Panel, Helm Switch 1 of 2.	41
Harness, Hull	18	Panel, Helm Switch 2 of 2.	42
Harness, Console	19	Panel, Battery, Triple 1 of 2	43
Harness, Deck, Port.	20	Panel, Battery, Triple 2 of 2	44
Harness, Deck, STBD	21	Panel, Battery, Twin 1 of 2	45
Harness, Hard Top	22	Panel, Battery, Twin 2 of 2	46
Harness, Hard Top Panel Kit 1 of 5.	23	Pig Tail, Amplifier Kit.	47
Harness, Hard Top Panel Kit 2 of 5.	24	Kit, Awning	48
Harness, Hard Top Panel Kit 3 of 5.	24		
Harness, Hard Top Panel Kit 4 of 5.	25		

This Page Intentionally Left Blank

INTRODUCTION

Congratulations and Welcome Aboard! With so many boat brands to choose from, we want to congratulate you on your decision to choose Sea Fox Boats. For more than 24 years, Sea Fox offers the finest hand-crafted saltwater boats carefully balanced with the build-quality, features, styling and performance for the fairest price. Our passion for boating is evident in every model we make and we appreciate that you've noticed the Sea Fox difference.

We share your love for the moments spent on the water with friends and family, which is why every Sea Fox boat offers a unique blend of fishing/family options, technologies and innovative features. Your choice of a Sea Fox affirms that you have performed your research and compared the value of your model with the competition.

Whether you are new to the boating lifestyle or an old salt, we ask that **you and all other operators** read the owner's manual, this supplement, and all other literature provided with the boat **before** operating the boat or any equipment. We also recommend that all operators enroll in a boating safety course available online - see References and Contact Information in this section for education resources online.

This supplement contains model-specific information not included with the owner's manual. This manual is not intended to be a replacement for specific product literature provided by engine, accessory or other major equipment manufacturers, but rather to supplement that information.

Because of our philosophy of continuous product improvement, this manual serves as a general guide only, so the specifications and illustrations used may not match the equipment on your boat and are intended only as general reference views.

We welcome you to the Sea Fox family and wish you many years of boating enjoyment!

SPECIFICATIONS

Max. Weight Capacity	Yacht Certification
Persons	Yacht Certification
Persons Weight	Yacht Certification
Max. HP	1200 hp (895 kW)
L.O.A.	36' (10.97 m)
Beam	11' (3.35 m)
Draft	27.5" (0.70 m)
Height, Keel to Top (Light Folded)	**
Bridge Clearance Hard Top	127.5" (3.24 m)
Max. Weight Boat (w/ Fluids, Largest HP, Batteries & Gear)	20,173 lbs (9150.32 kg)
Fuel Tank Capacity (Gasoline)	382 gal (1446 L)
Fuel Tank Capacity (Diesel)	12 gal (45 L)
Freshwater Tank Capacity	30 gal (114 L)
Holding Tank Capacity	12 gal (45 L)

* Keel to Top - 136" (3.45 m), W/outriggers 142" (3.61 m), W/open array radar 155" (3.94 m)

DESIGNATED OCCUPANT SEATING

Be sure all passengers are properly seated in designated seating positions and not riding on the bow, bow pulpit, deck, gunwale or rear sun deck while underway. Passengers must use hand-holds and use caution when riding in the bow. Move to the aft passenger seats during rough water operation or if visibility is restricted.

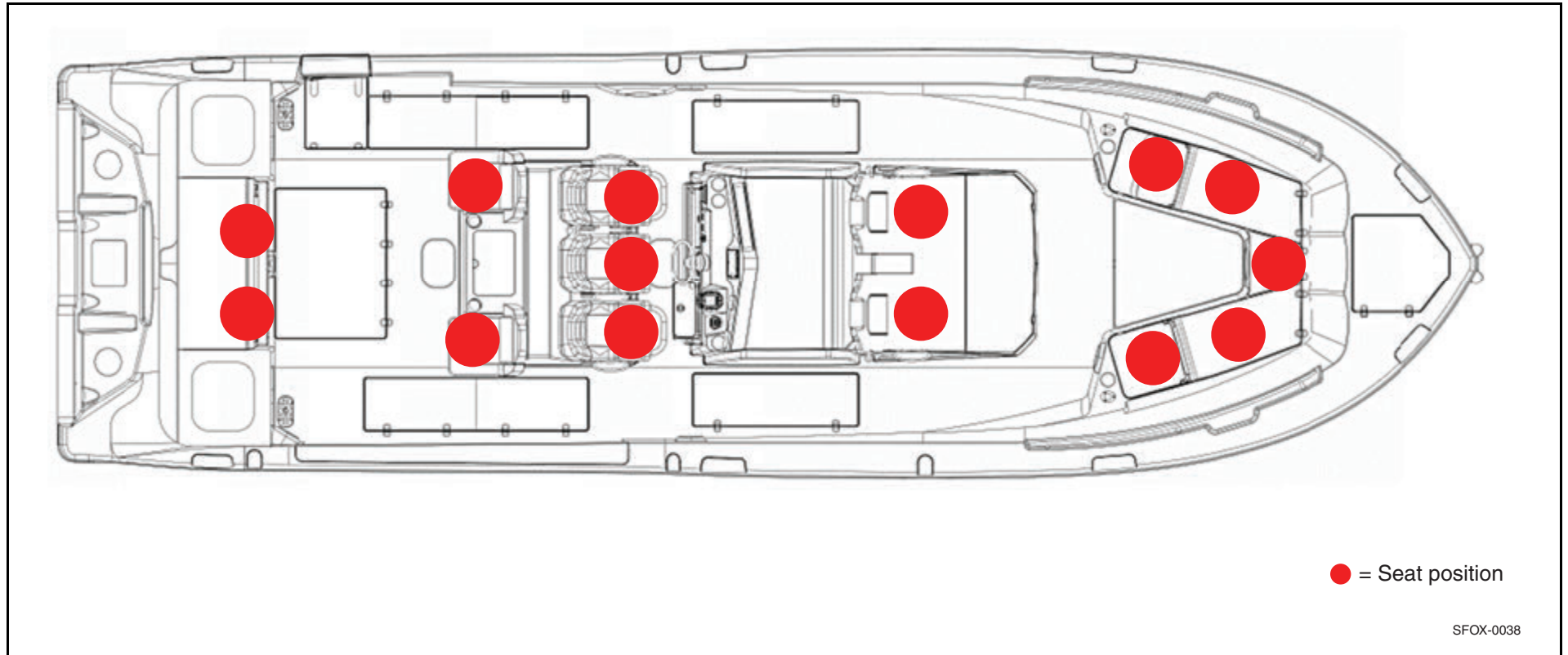

SAFETY DECALS

6 **WARNING**

CARBON MONOXIDE (CO) CAN CAUSE BRAIN DAMAGE OR DEATH.

- Carbon monoxide can be present in the cabin.
- Signs of carbon monoxide poisoning include nausea, headache, dizziness, drowsiness, and lack of consciousness.

MOVE TO FRESH AIR if anyone shows signs of carbon monoxide poisoning.

USE AVAILABLE HANDRAILS AND HANDHOLDS while moving about the cabin and while the boat is in motion to avoid falling.

US0419-01



8 **NO WOOD! NO ROT!**

US0601-01

4 **WARNING** **GAS / PETROL ONLY**

CONTENTS CAN BE UNDER PRESSURE. AVOID SERIOUS INJURY OR DEATH FROM FIRE OR EXPLOSION. OPEN SLOWLY IN WELL VENTILATED AREA. NO SMOKING OR OPEN FLAMES.

E-15

US0608-01

3 **WARNING**

Leaking fuel is a fire and explosion hazard.

Avoid serious injury or death from fire or explosion from leaking fuel. Inspect system for leaks at least once a year.

1 **WARNING**

Failure to follow these warnings could cause **SERIOUS INJURY** or **DEATH**.

- REMAIN PROPERLY SEATED AND HOLD ON to available handrails while boat is moving to avoid falling overboard or being ejected from the boat. Do not sit on seat backs, gunwales or outmost deck edges.
- WEAR U.S. COAST GUARD APPROVED LIFE JACKETS.
- DO NOT OVERLOAD THE BOAT. OCCUPANTS AND GEAR MUST BE PROPERLY AND EVENLY DISTRIBUTED fore and aft, and on both sides of the boat. Improper loading and/or overloading may result in poor handling, sudden loss of control, swamping and/or capsizing.
- REFER TO AND OBEY THE DESIGNATED OCCUPANT SEATING POSITIONS that are indicated by the manufacturer for your specific model.
- OBEY THE OPERATOR at all times.
- DO NOT RESTRICT THE OPERATOR'S VISION.
- DO NOT DEPART THE VESSEL without informing the operator.

US0419-01

2 **NOTICE**

THIS BOAT IS EQUIPPED WITH AN OPTIONAL DIRECT OVERBOARD DISCHARGE VALVE. DISCHARGING OF SEWAGE DIRECTLY OVERBOARD IS FOR USE WHERE APPROVED ONLY.

US0419-01

2 **NOTICE**

SHUT OFF VALVE(S) LOCATED BEHIND ACCESS PANEL. CLOSE VALVE(S) WHEN NOT IN USE.

US0708-02

3 **WARNING**

Failure to follow these warnings could cause severe injury or death

- WEAR SAFETY LANYARD at all times while operating boat to prevent unmanned boat operation.
- NEVER OPERATE WHILE UNDER THE INFLUENCE of drugs or alcohol.
- DO NOT OVERLOAD THE BOAT. ENSURE THAT WEIGHT IS PROPERLY AND EVENLY DISTRIBUTED fore and aft and on both sides of the boat to avoid poor handling sudden loss of control, swamping and/or capsizing.
- PASSENGERS SHOULD WEAR U.S. COAST GUARD APPROVED LIFE JACKETS.
- MAKE SURE THAT ALL PASSENGERS ARE PROPERLY SEATED WHILE UNDERWAY. To avoid passengers falling overboard or being ejected from the boat, do not allow passengers to sit on seat backs, gunwales or outmost deck edges while boat is moving.
- REDUCE SPEED BEFORE ATTEMPTING SUDDEN OR SHARP TURNS.
- AND MAINTAIN SAFE SPEEDS for water conditions and environment at all times. Maneuverability at high speeds is limited, and sudden turns may cause loss of boat control.
- KEEP PROPER LOOKOUT AND SAFE DISTANCE for the conditions at all times to avoid collisions.
- OBEY APPLICABLE NAVIGATION RULES AND BOATING LAWS.
- USE CAUTION AND PROPER LIGHTING during nighttime boating and boating in adverse weather.
- READ THE OWNER'S MANUAL AND COMPLETE THE BOATER'S PRE-OPERATION CHECKLIST prior to boat operation.

US0419-01

8 **ANGER**

ROTATING PROPELLER CAN CAUSE SERIOUS INJURY OR DEATH. SHUT OFF MOTOR WHEN NEAR PERSONS IN WATER.

US0109-02

8 **ANGER**

ROTATING PROPELLER CAN CAUSE SERIOUS INJURY OR DEATH. SHUT OFF MOTOR WHEN NEAR PERSONS IN WATER.

US0109-02

6 **WARNING**

Failure to follow these warnings could cause **SERIOUS INJURY** or **DEATH**.

- REMAIN PROPERLY SEATED AND HOLD ON to available handrails while boat is moving to avoid falling overboard or being ejected from the boat. Do not sit on seat backs, gunwales or outmost deck edges.
- WEAR U.S. COAST GUARD APPROVED LIFE JACKETS.
- DO NOT OVERLOAD THE BOAT. OCCUPANTS AND GEAR MUST BE PROPERLY AND EVENLY DISTRIBUTED fore and aft, and on both sides of the boat. Improper loading and/or overloading may result in poor handling, sudden loss of control, swamping and/or capsizing.
- REFER TO AND OBEY THE DESIGNATED OCCUPANT SEATING POSITIONS that are indicated by the manufacturer for your specific model.
- OBEY THE OPERATOR at all times.
- DO NOT RESTRICT THE OPERATOR'S VISION.
- DO NOT DEPART THE VESSEL without informing the operator.

US0419-01

4 **WARNING** **GAS / PETROL ONLY**

CONTENTS CAN BE UNDER PRESSURE. AVOID SERIOUS INJURY OR DEATH FROM FIRE OR EXPLOSION. OPEN SLOWLY IN WELL VENTILATED AREA. NO SMOKING OR OPEN FLAMES.

E-15

US0608-02

Manufactured by **SEA FOX BOAT WORKS**

2 **NON POTABLE WATER**

US0271-01

5 **NON POTABLE WATER**

US0271-01

6 **NOTICE**

SHUT OFF VALVE(S) LOCATED BEHIND ACCESS PANEL. CLOSE VALVE(S) WHEN NOT IN USE.

US0708-02

6 **RAW WATER**

US0271-01

5 **FRESH WATER**

US0271-01

3 **WARNING**

Operating, servicing and maintaining a recreational marine vessel can expose you to chemicals including engine exhaust, carbon monoxide, phthalates, and lead, which are known to the State of California to cause cancer and birth defects or other reproductive harm. To minimize exposure, avoid breathing exhaust, service your vessel in a well-ventilated area and wear gloves or wash your hands frequently when servicing this vessel. For more information go to www.P60warnings.ca.gov/marine.

US0419-01

3 **WARNING**

Rotating propeller may cause serious injury or death. Shut off engine when near persons in the water.

Carbon monoxide (CO) can cause brain damage or death. Engine and generator exhaust contains odorless and colorless carbon monoxide gas. Signs of carbon monoxide poisoning include nausea, headache, dizziness, drowsiness, and lack of consciousness. Get fresh air if anyone shows signs of carbon monoxide poisoning. See Owner's Manual for information regarding carbon monoxide poisoning.

Leaking fuel is a fire and explosion hazard. Avoid serious injury or death from fire or explosion from leaking fuel. Inspect system for leaks at least once a year.

US0704-01

SEA FOX BOAT COMPANY
MEETS U.S. EPA E/VP STANDARDS USING CERTIFIED COMPONENTS

5 **WARNING**

Moving parts can crush and cut. Keep hands clear while operating bracket.

US0708-02

3 **SEA FOX BOAT WORKS**

YACHT CERTIFICATION

THIS BOAT COMPLIES WITH THE U.S. COAST GUARD SAFETY STANDARDS IN EFFECT ON THE DATE OF CERTIFICATION

SEA FOX BOAT COMPANY
MONCK'S CORNER, S.C.

5 **AIR CONDITIONER**

US0608-01

7 **WARNING**

PINCH POINT

Watch your hands and fingers when opening and closing cover.

AVOID PERSONAL INJURY SECURE GATE/DOOR WHEN BOAT IS UNDERWAY. ENSURE LADDER IS SECURED TO DECK PRIOR TO USING IF EQUIPPED.

US0704-01

It is illegal for any vessel to dump plastic ANYWHERE in the ocean or navigable waters of the United States, Annex V of MARPOL TREATY is an International Law for a cleaner, safer marine environment. Violation of these requirements is a Class D Felony and may result in a civil penalty, up to \$25,000 fine and imprisonment.

U.S. lakes, rivers, bays or sounds and 3 miles from shore	3 to 12 miles	12 to 25 miles	Outside 25 miles
ILLEGAL TO DUMP: Plastic	ILLEGAL TO DUMP: Plastic	ILLEGAL TO DUMP: Plastic	ILLEGAL TO DUMP: Plastic
Plastic and Garbage	Dunnage, lining and packing materials that float; also if not ground to less than one inch	Dunnage, lining and packing materials that float.	
Paper	Metal		
Rags	Crockery		
Glass	Dunnage		
Food	Paper	Crockery	
	Rags	Metal	
	Glass	Food	

Regional state and local regulations may further restrict the disposal of garbage. The discharge of all garbage into the Great Lakes or their connecting or tributary waters is prohibited.

8 **DANGER**

Carbon monoxide (CO) can cause brain damage or death. Engine and generator exhaust contains odorless and colorless carbon monoxide gas. Carbon monoxide will be around the back of the boat when engines or generators are running. Move to fresh air, if you feel nausea, headache, dizziness, or drowsiness.

US0608-01

2 **DISCHARGE OF OIL PROHIBITED**

THE FEDERAL WATER POLLUTION CONTROL ACT PROHIBITS THE DISCHARGE OF OIL OR OILY WASTE INTO OR UPON THE NAVIGABLE WATERS OF THE UNITED STATES, OR THE WATERS OF THE CONTIGUOUS ZONE, OR WHICH MAY AFFECT NATURAL RESOURCES BELONGING TO, APPERTAINING TO, OR UNDER THE EXCLUSIVE MANAGEMENT AUTHORITY OF THE UNITED STATES, IF SUCH DISCHARGE CAUSES A FILM OR DISCOLORATION OF THE SURFACE OF THE WATER OR CAUSES A SLUDGE OR EMULSION BENEATH THE SURFACE OF THE WATER. VIOLATORS ARE SUBJECT TO SUBSTANTIAL CIVIL PENALTIES AND/OR CRIMINAL SANCTIONS INCLUDING FINES AND IMPRISONMENT.

- 1= COCKPIT FRONT
- 2= HEAD COMPARTMENT
- 3= CONSOLE
- 4= FUEL FILL
- 5= COCKPIT MID SHIP
- 6= COCKPIT AFT
- 7= DIVE DOOR
- 8= TRASOM

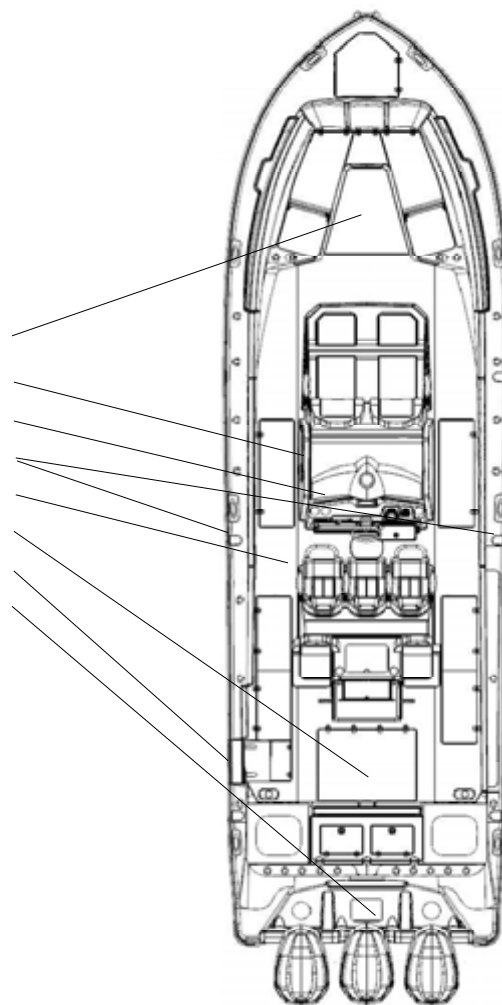

PLUMBING SCHEMATICS

PLUMBING, DECK 1 OF 2

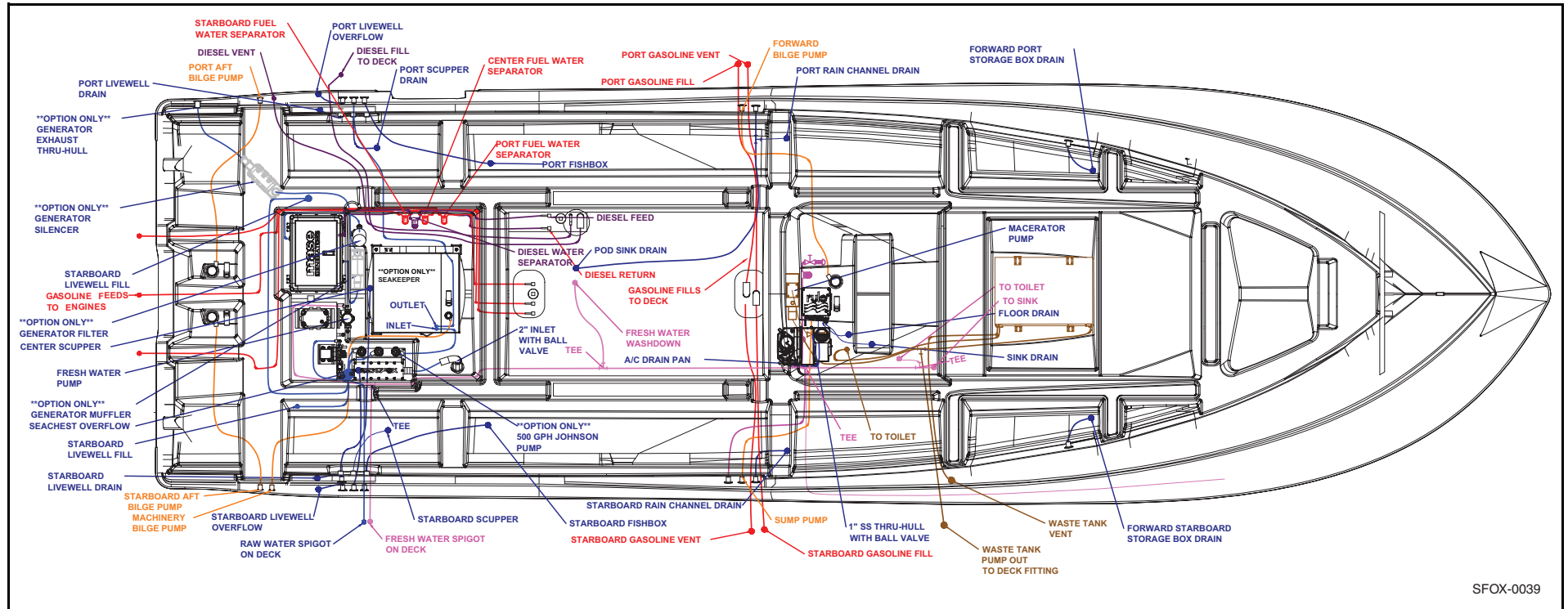

PLUMBING, DECK 2 OF 2

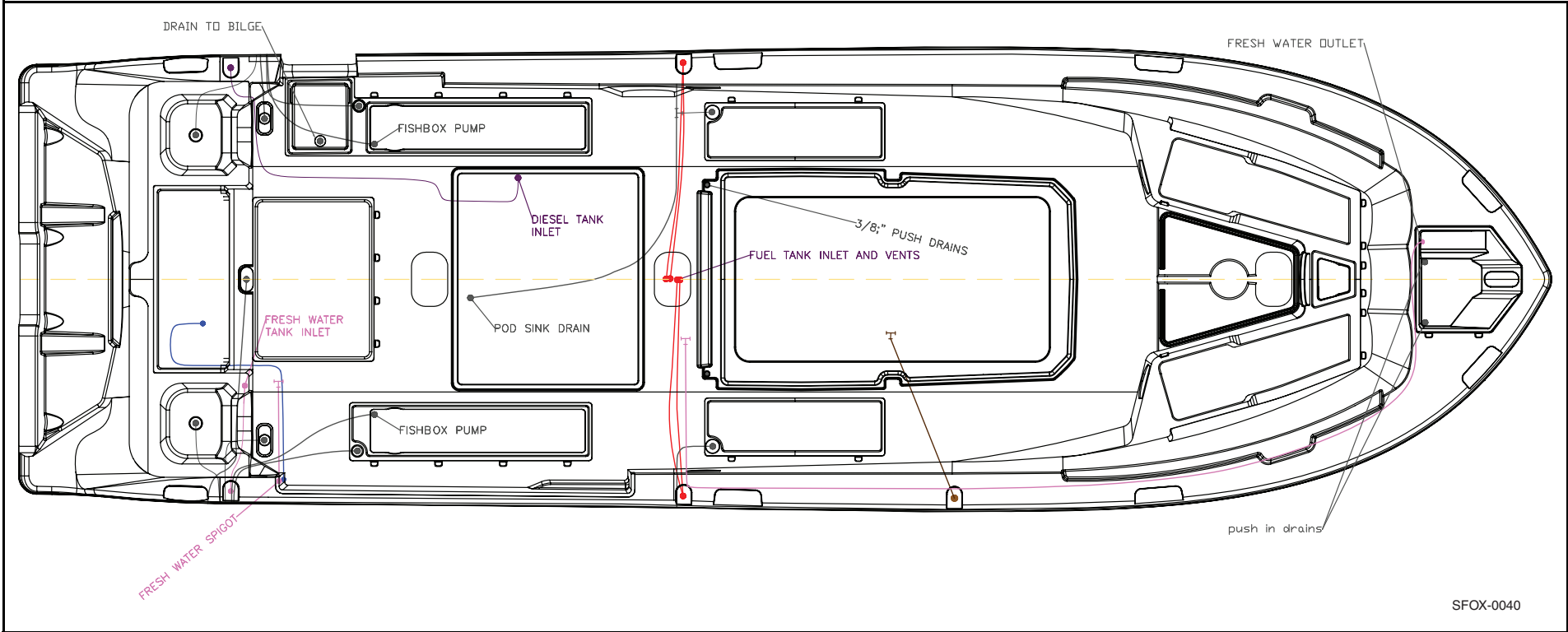

DRAINS, FORWARD

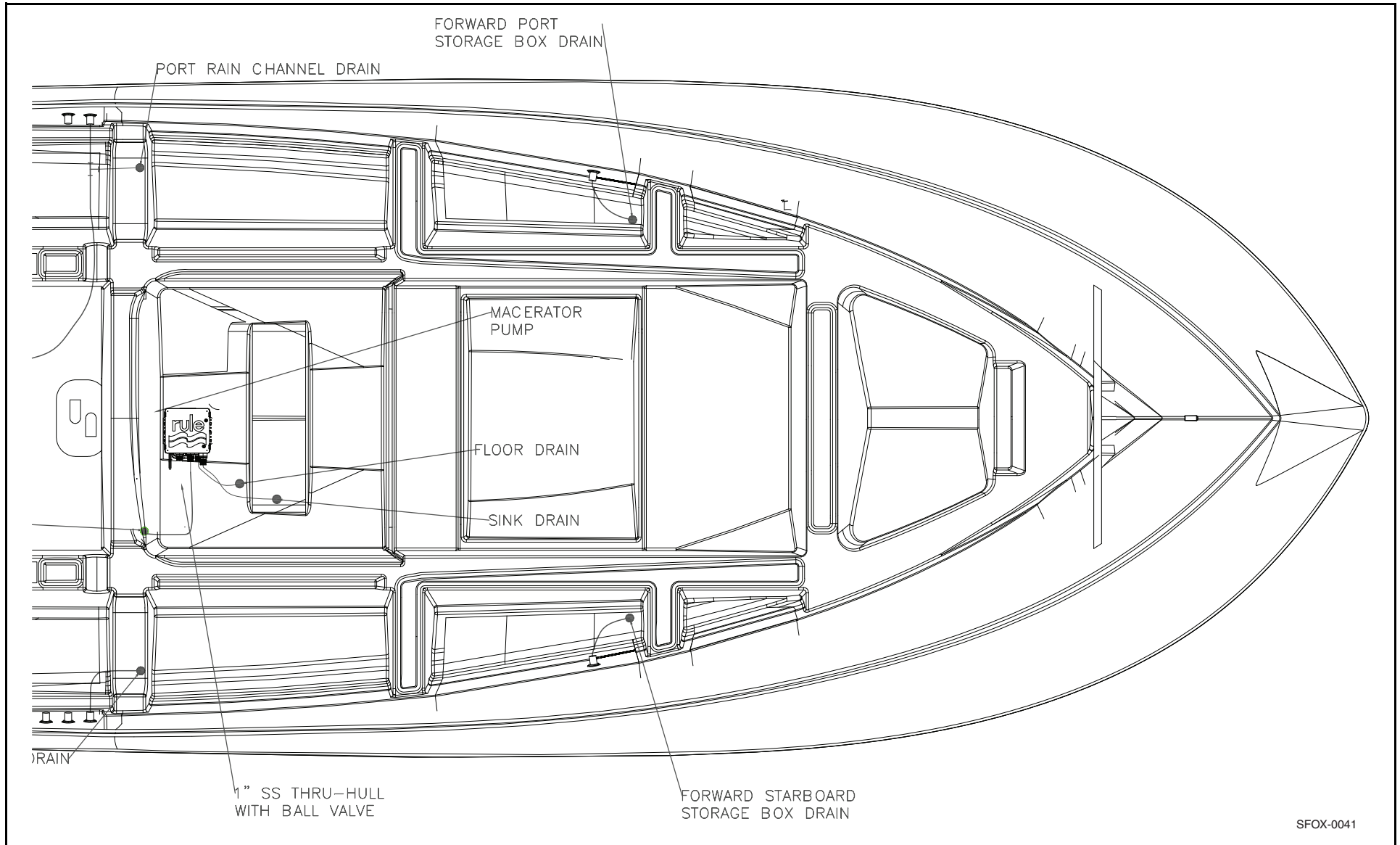

DRAINS, AFT

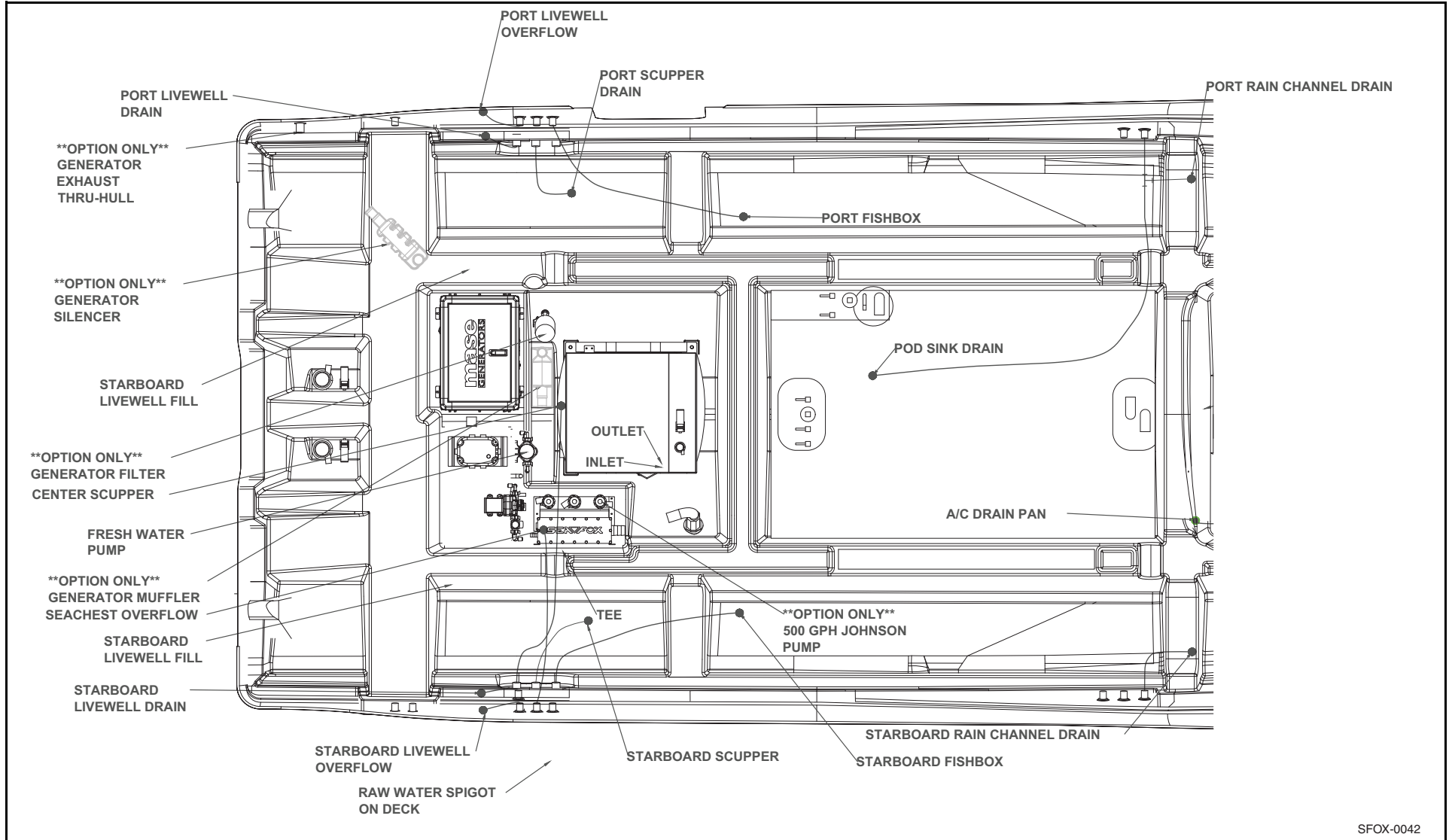

SFOX-0042

DRAINS, BILGE

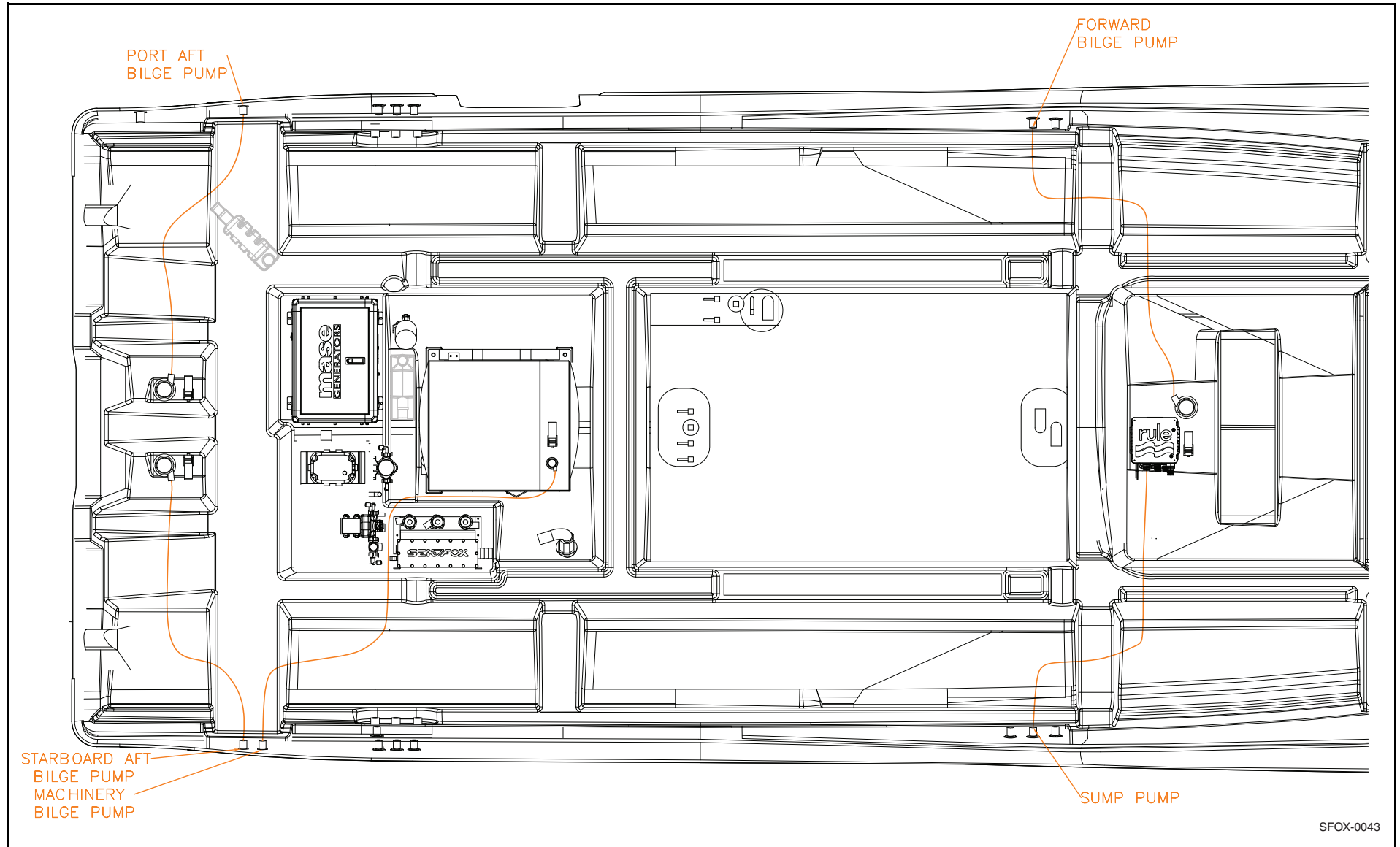

SFOX-0043

FRESHWATER SYSTEM, HULL

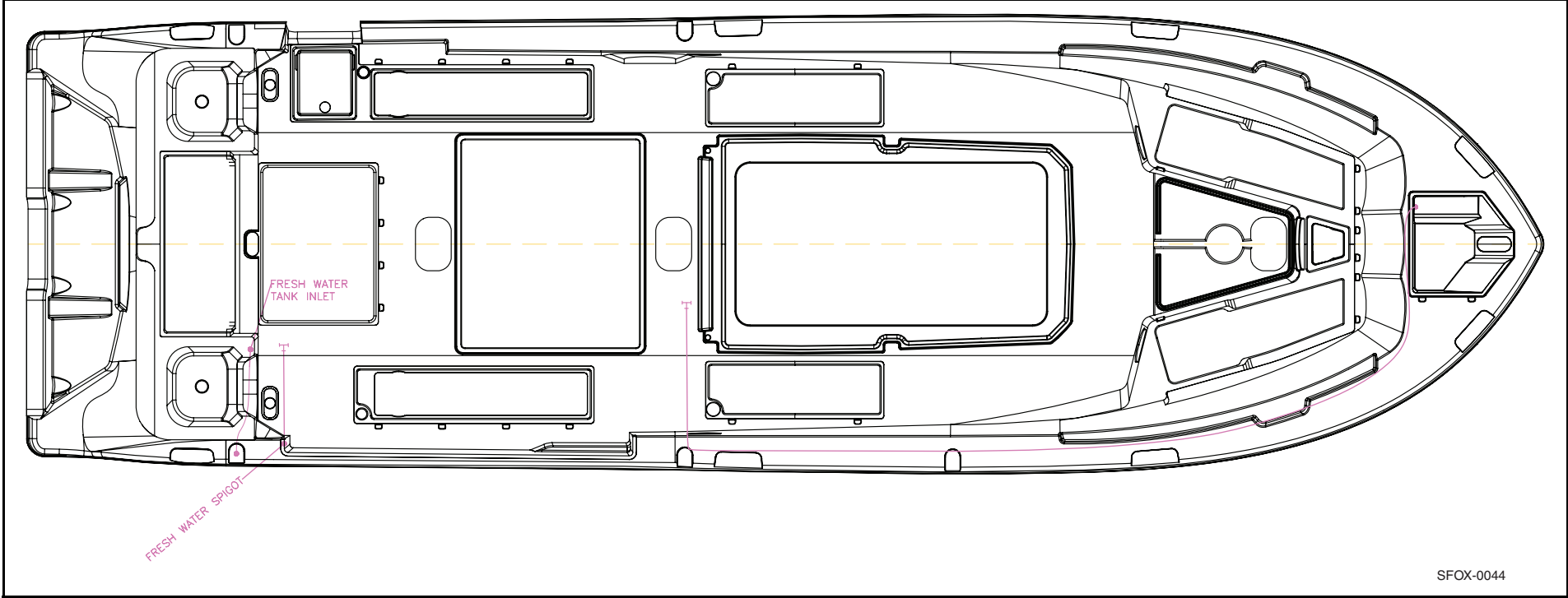

FRESHWATER SYSTEM, DECK

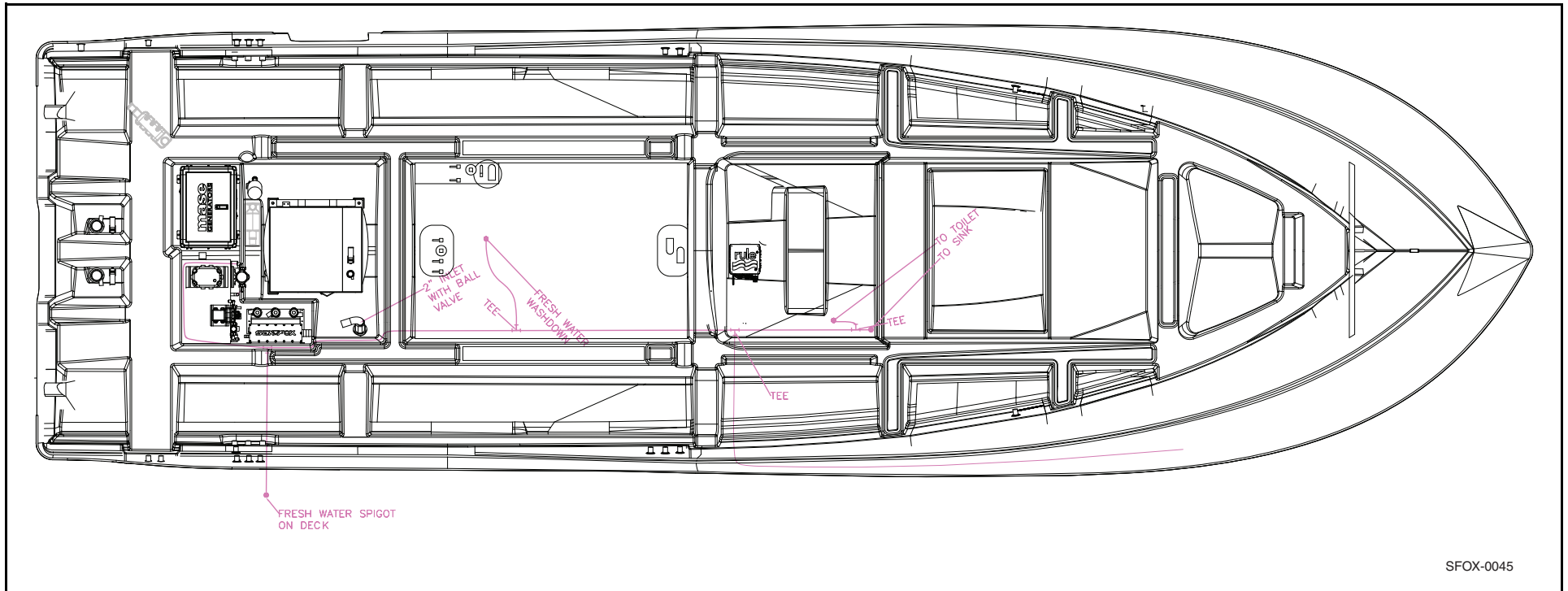

SFOX-0045

RAW WATER SYSTEM

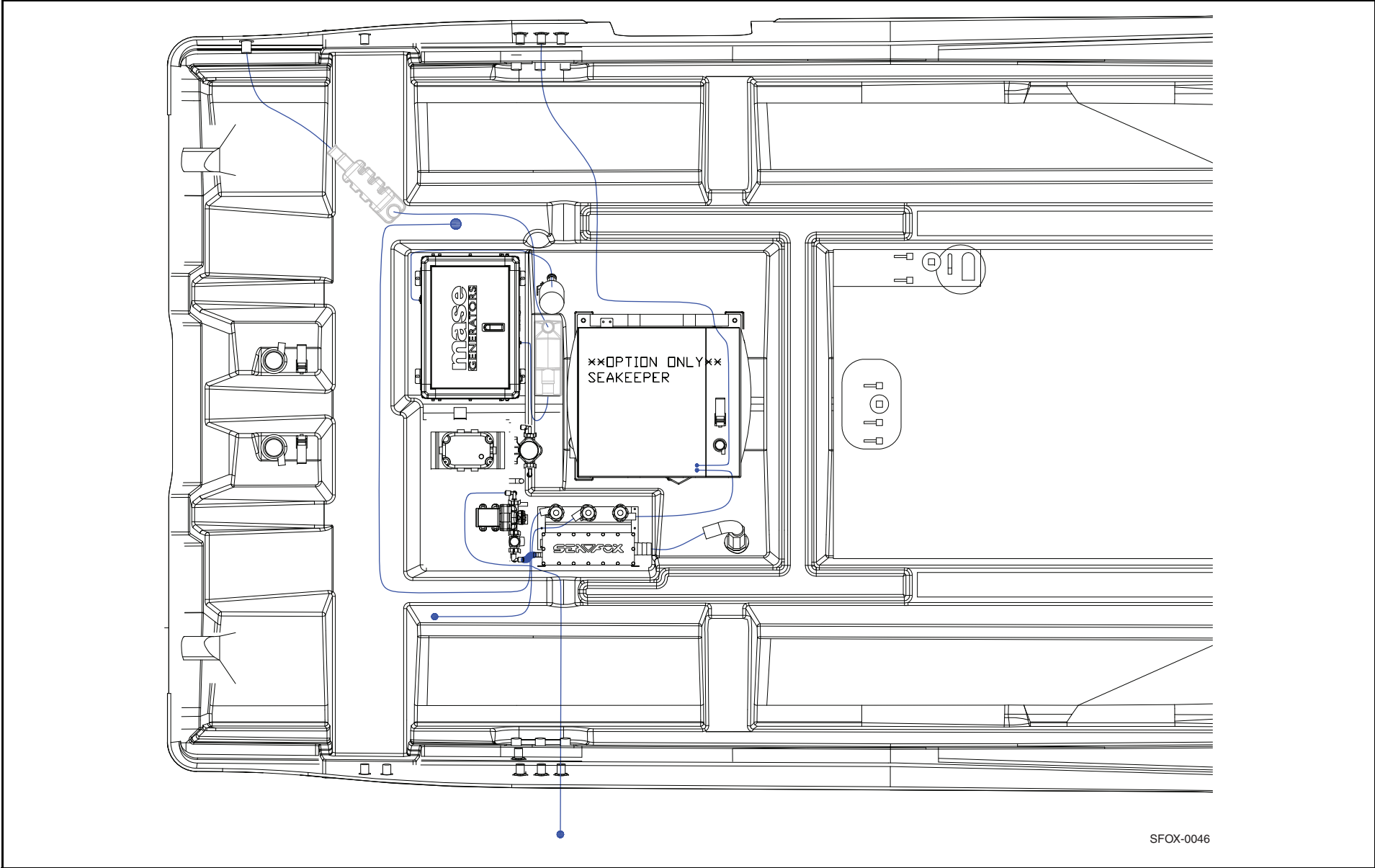

WASTE WATER SYSTEM

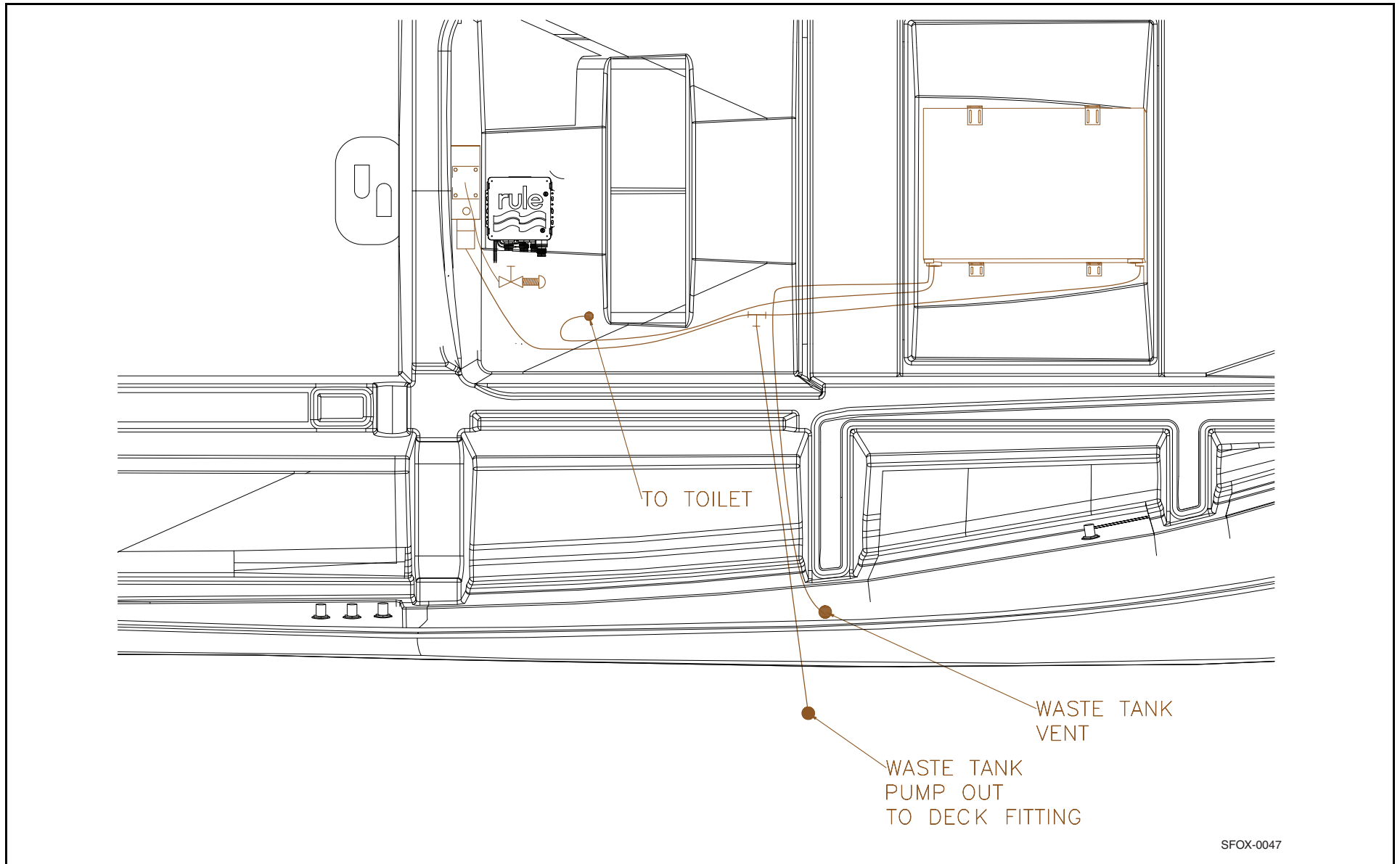

FUEL SYSTEM, GASOLINE

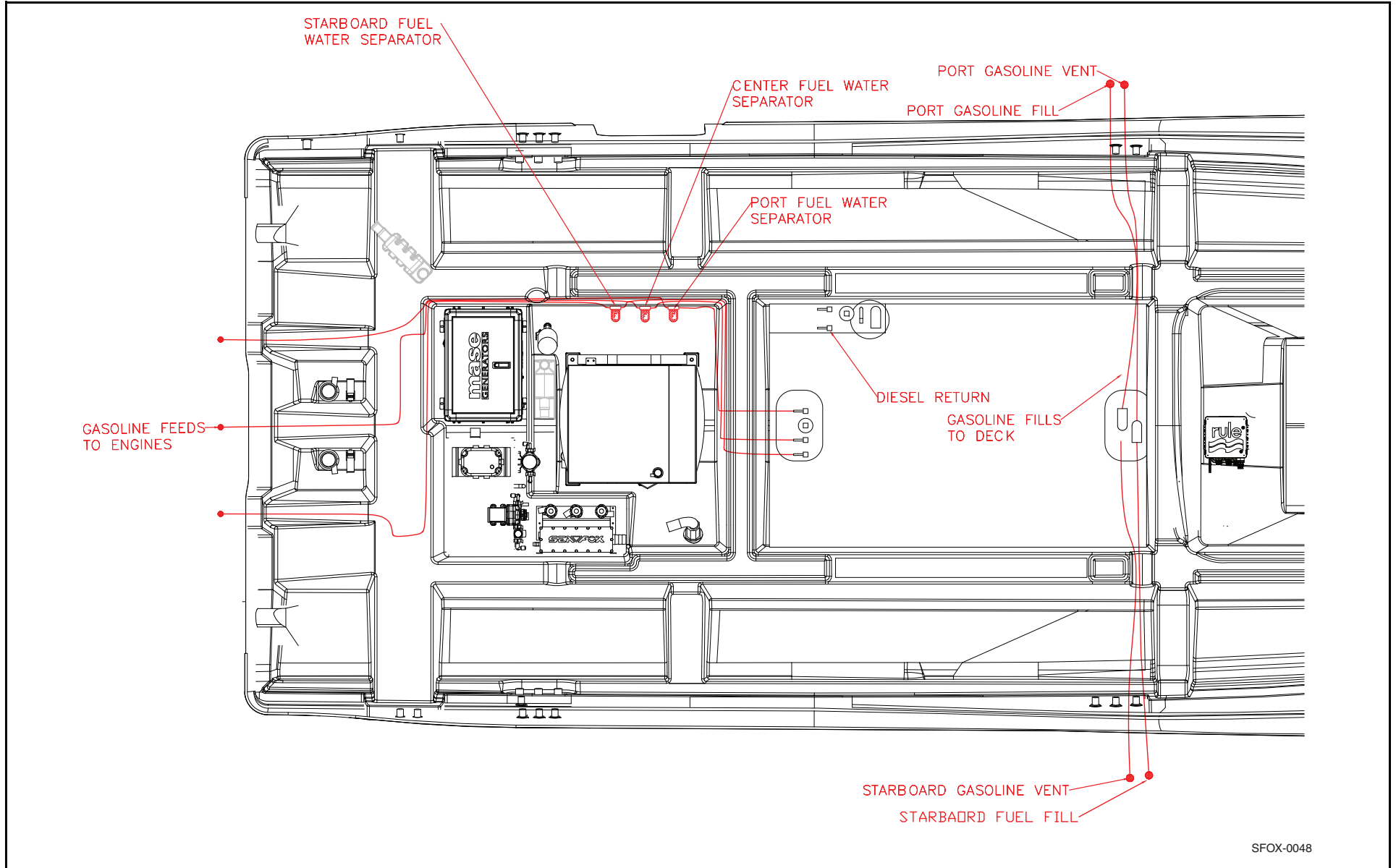

FUEL SYSTEM, DIESEL

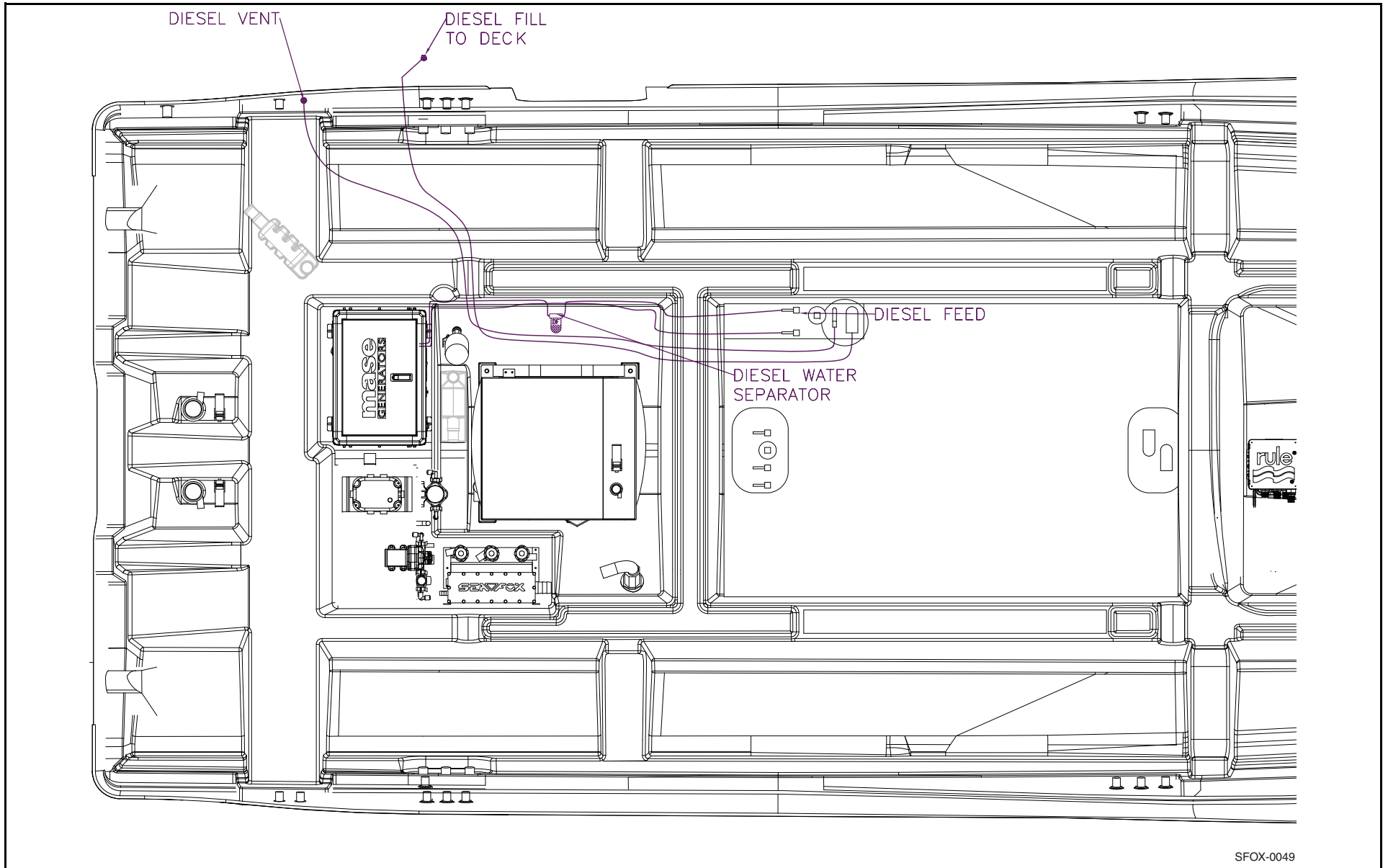

ELECTRICAL SCHEMATICS

HARNESS, HULL

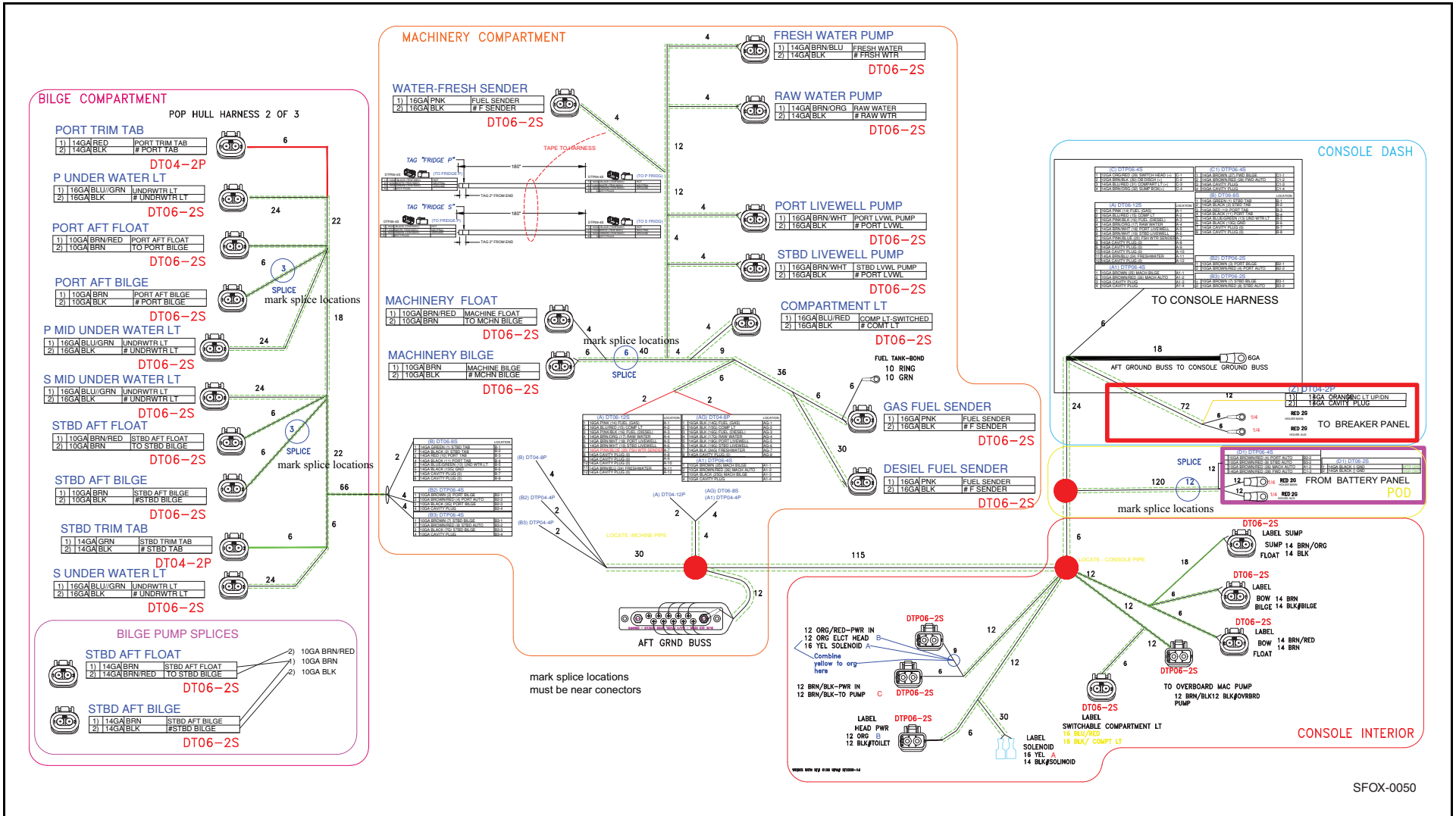

HARNES, CONSOLE

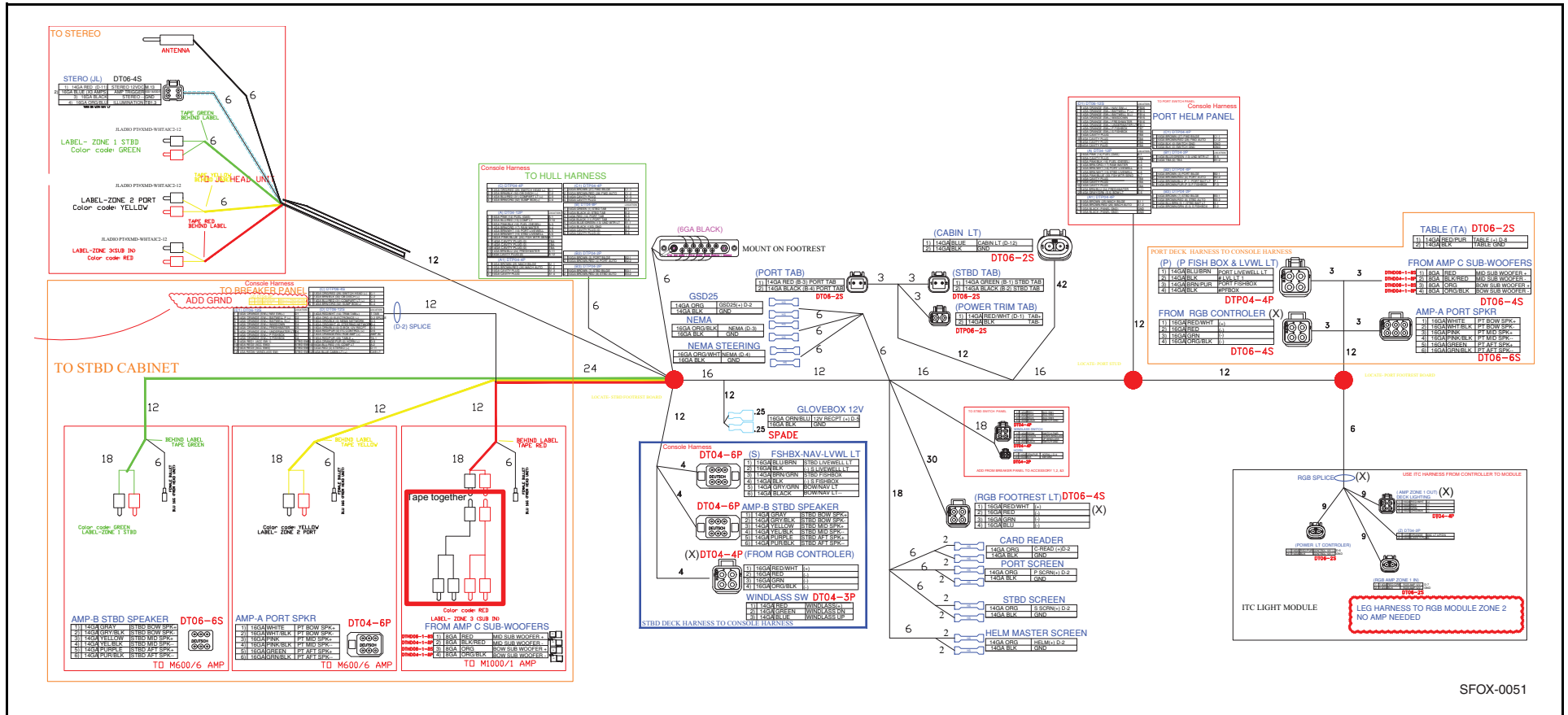

SFOX-0051

HARNESS, DECK, PORT

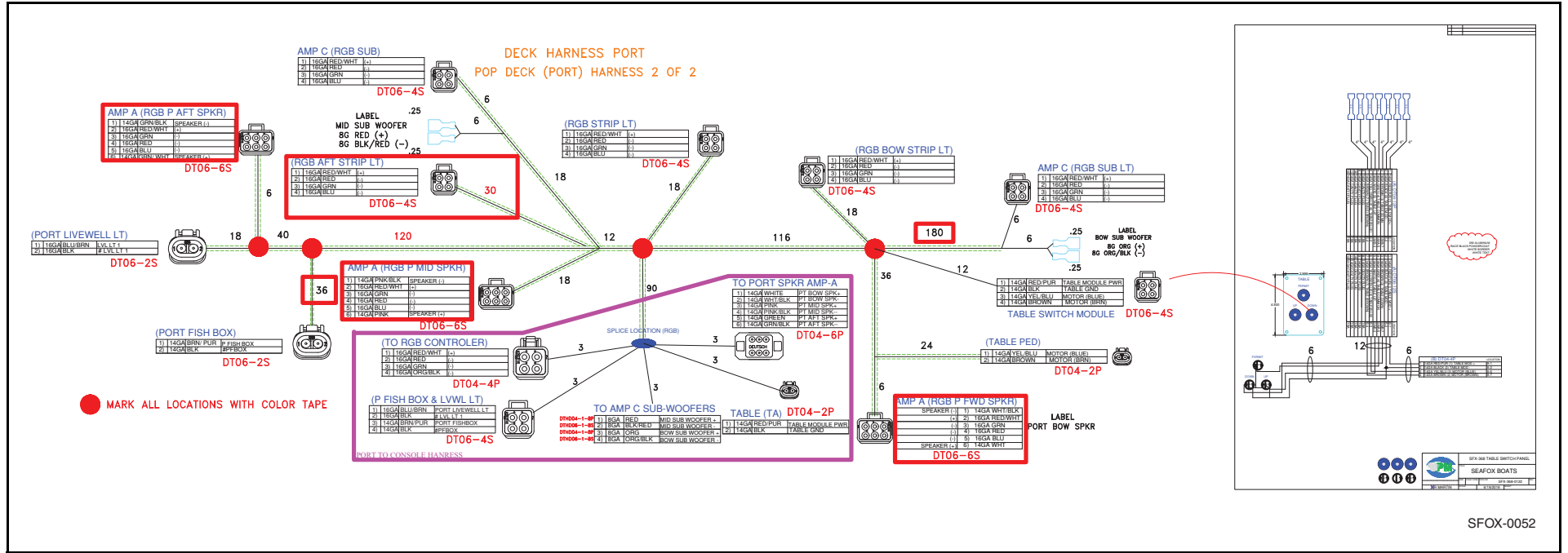

SFOX-0052

HARNES, DECK, STBD

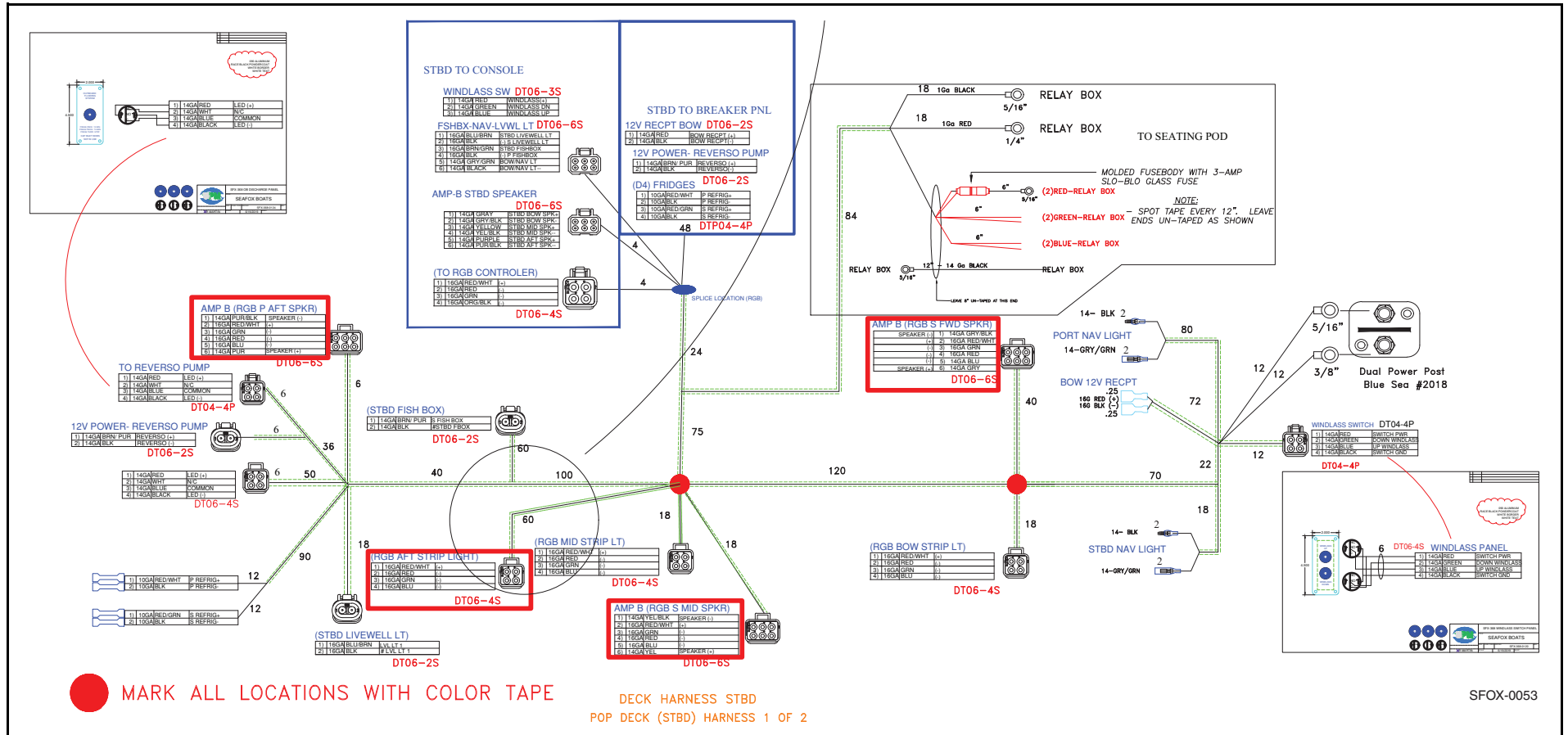

HARNES, HARD TOP

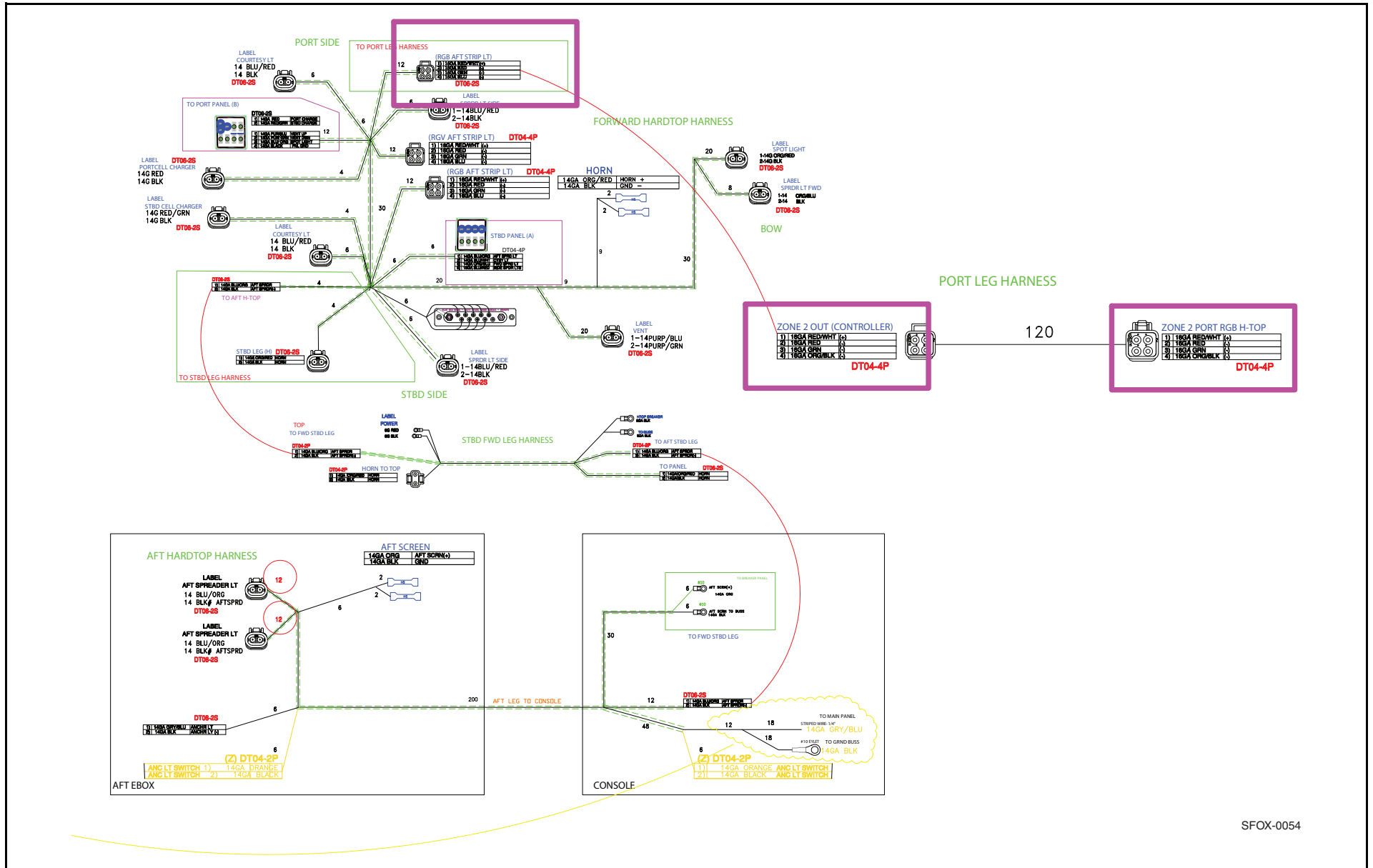

SFOX-0054

HARNES, HARD TOP PANEL KIT 1 OF 5

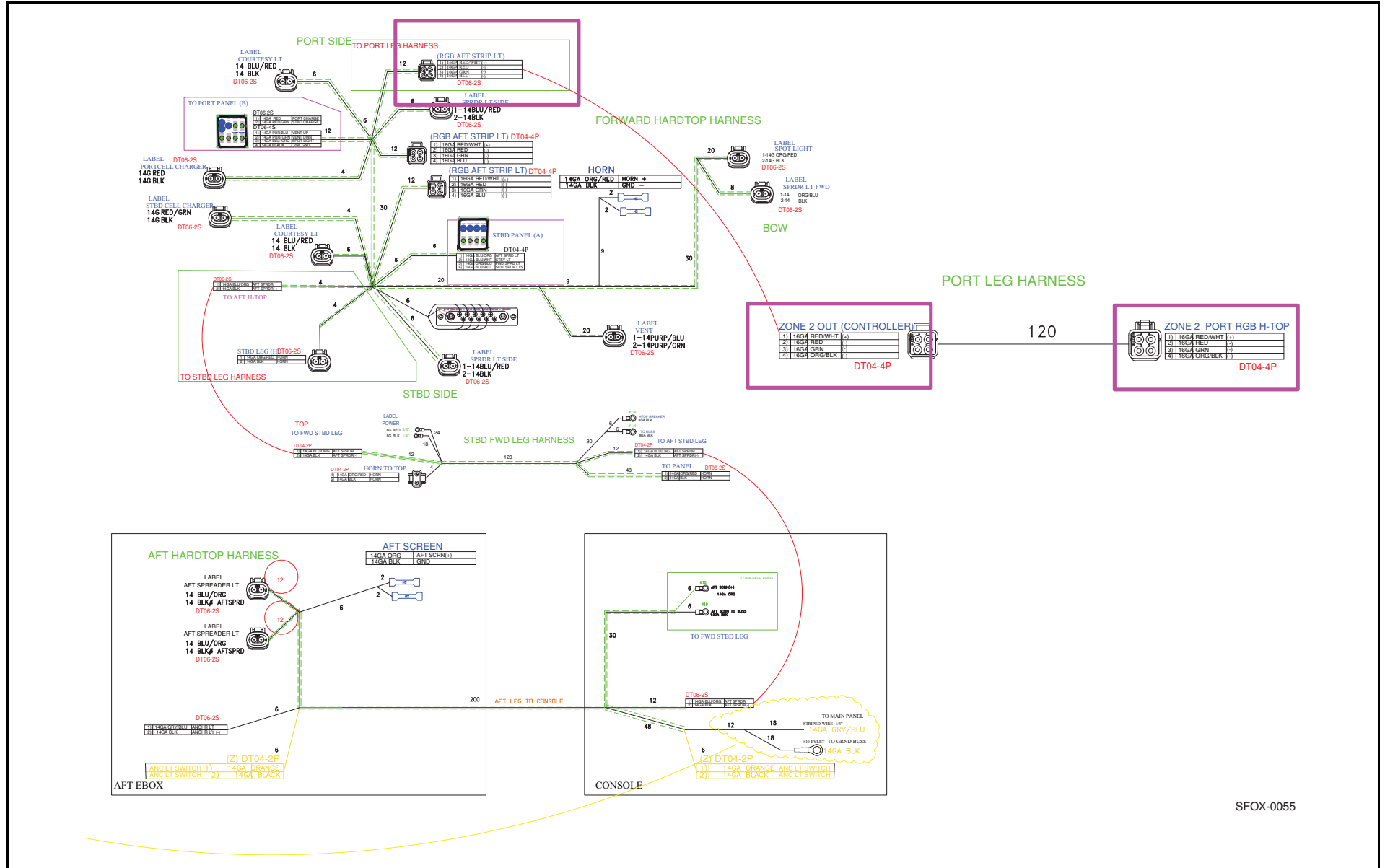

SFOX-0055

HARNES, HARD TOP PANEL KIT 2 OF 5

POWERED ANCHOR LIGHT

TO ACTUATED ANCHOR LIGHT

1)	16GA RED	+12V DC
2)	16GA BLK	MOTOR -
3)	PLUG	
4)	16GA BRN	UPPER LIMIT
5)	16GA GREEN	MOTOR +
6)	16GA WHT	LOWER LIMIT

DT04-6P

24

24

6

(Z) DT06-2S

1)	14 GA. ORG	+12 DC (ANC LT UP/DN)
2)	14 GA. BLK	GROUND

(BAG AND INCLUDE W/PANEL)

INCLUDE HOUSING, LOCK WEDGE, 1 PLUG 6 PINS IN BAG

DT06-6S

DRAWN TO 1:1 SCALE

SFOX-0056

HARNES, HARD TOP PANEL KIT 3 OF 5

POWERED ANCHOR LIGHT SCHEMATIC

LIGHT MOTOR CONNECTION

LIGHT SWITCH CONNECTION

SFOX-0084

HARNES, HARD TOP PANEL KIT 4 OF 5

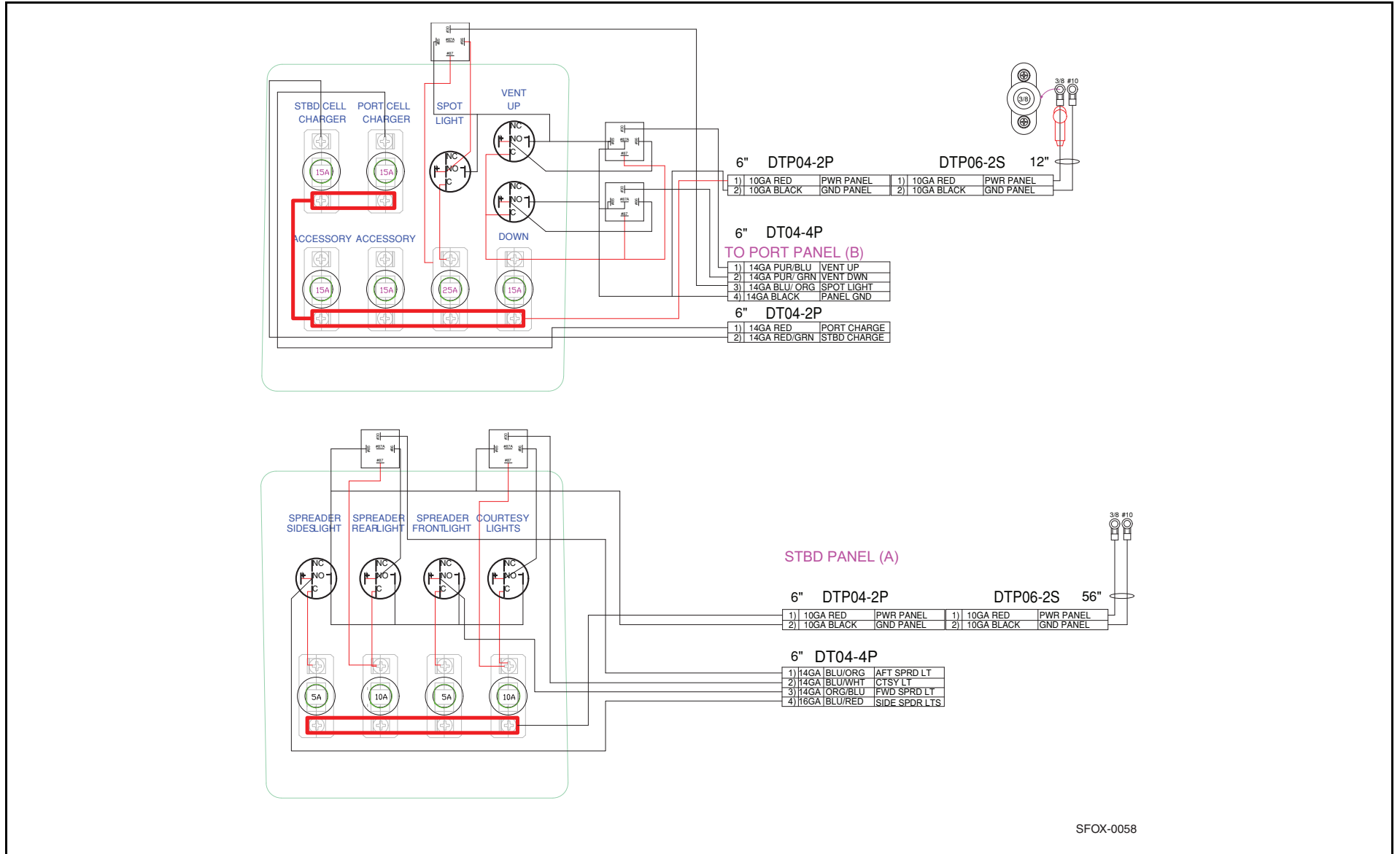

SFOX-0058

HARNES, HARD TOP PANEL KIT 5 OF 5

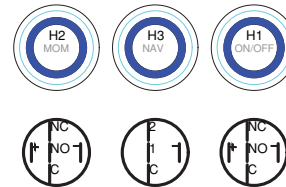
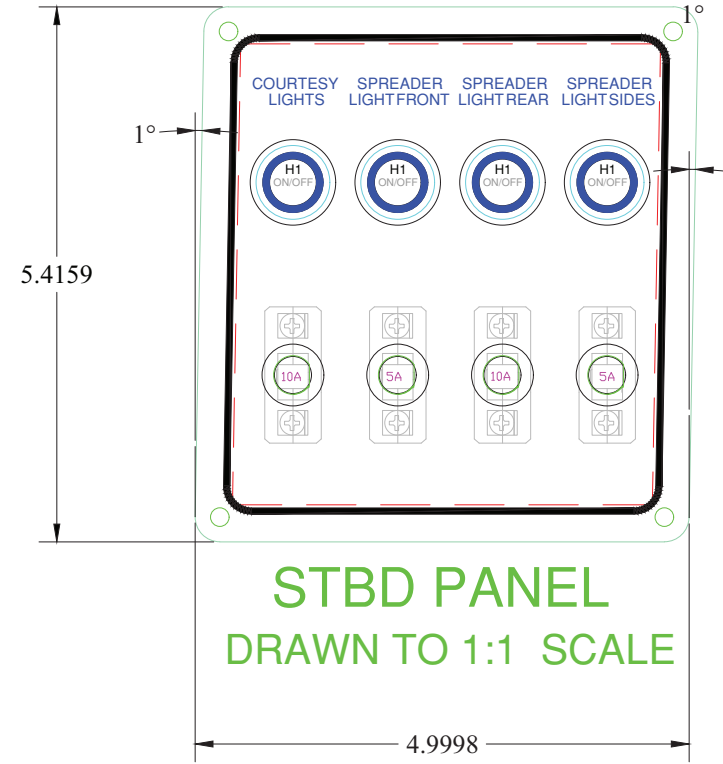
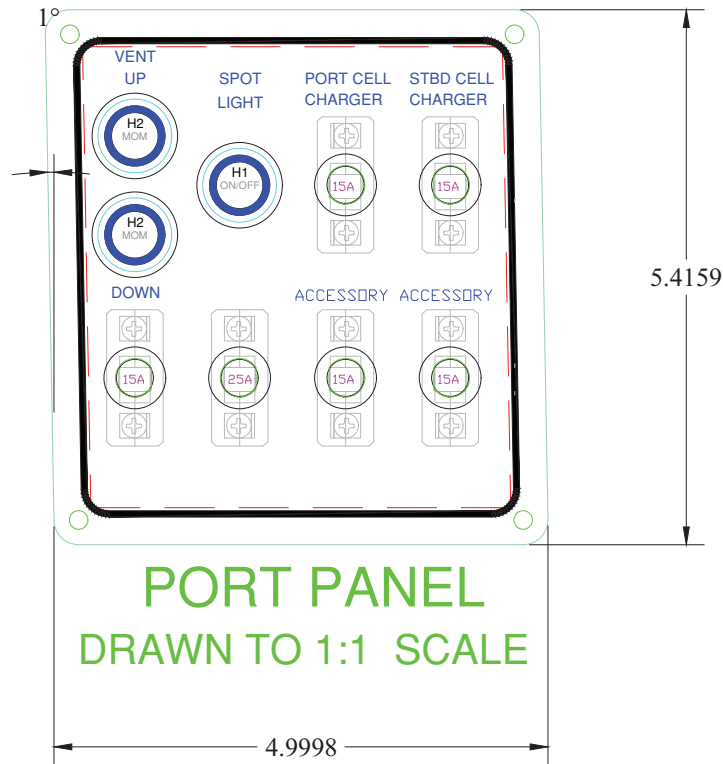

SFOX-0059

KIT, HARD TOP 1 OF 3

POWERED ANCHOR LIGHT

DRAWN TO 1:1 SCALE

TO ACTUATED ANCHOR LIGHT

1)	16GA RED	+12V DC
2)	16GA BLK	MOTOR -
3)	PLUG	
4)	16GA BRN	UPPER LIMIT
5)	16GA GREEN	MOTOR +
6)	16GA WHT	LOWER LIMIT

DT04-6P

24

24

6
(Z) DT06-2S

1)	1# GA ORG	+12 DC (ANC LT UP/DN)
2)	1# GA BLK	GROUND

(BAG AND INCLUDE W/PANEL)

INCLUDE HOUSING, LOCK WEDGE, 1 PLUG 6 PINS IN BAG

DT06-6S

SFOX-0060

KIT, HARD TOP 2 OF 3

POWERED ANCHOR LIGHT SCHEMATIC

LIGHT MOTOR CONNECTION

LIGHT SWITCH CONNECTION

SFOX-0084

KIT, HARD TOP 3 OF 3

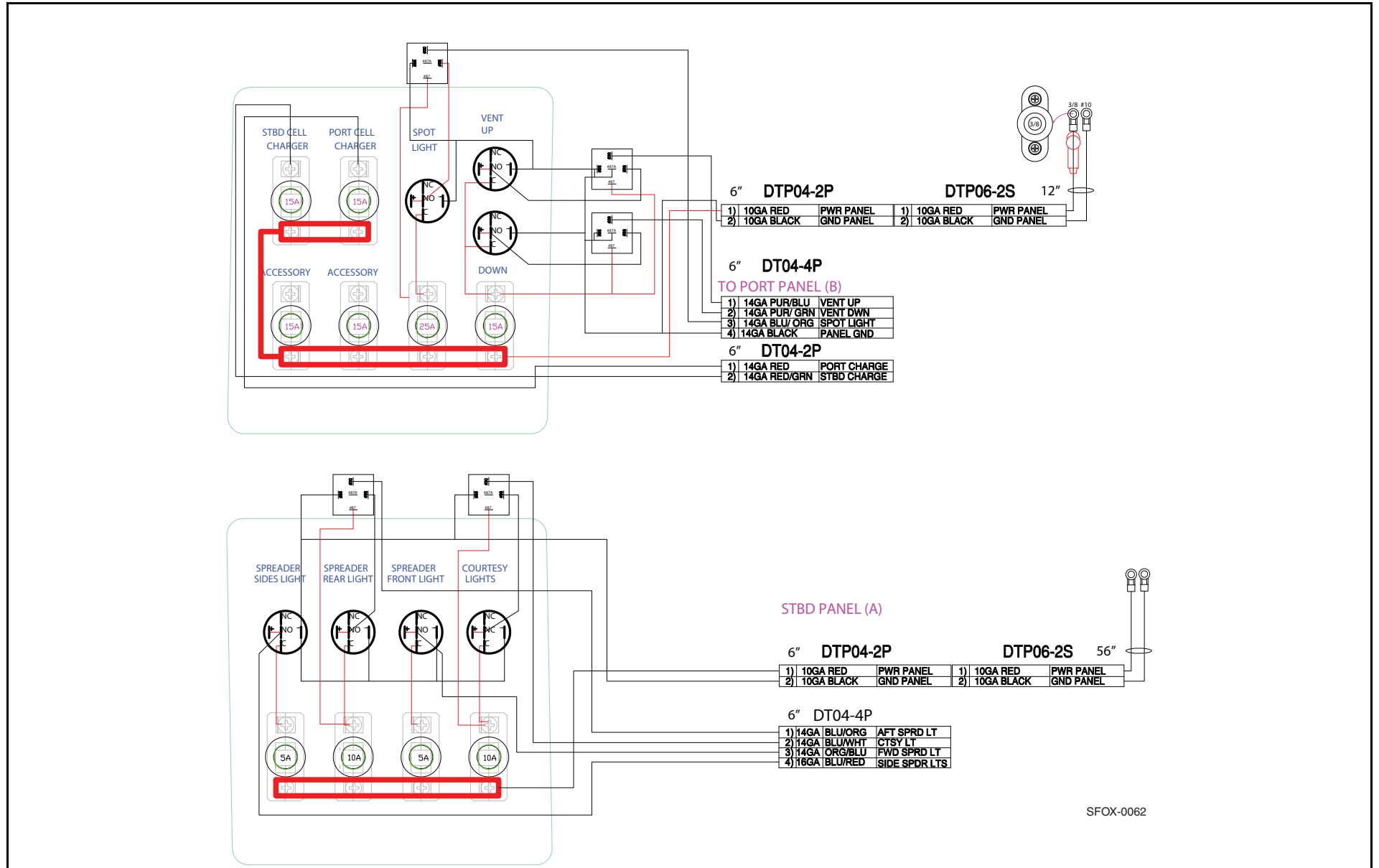

SFOX-0062

PANEL, MAIN DC DISTRIBUTION 1 OF 2

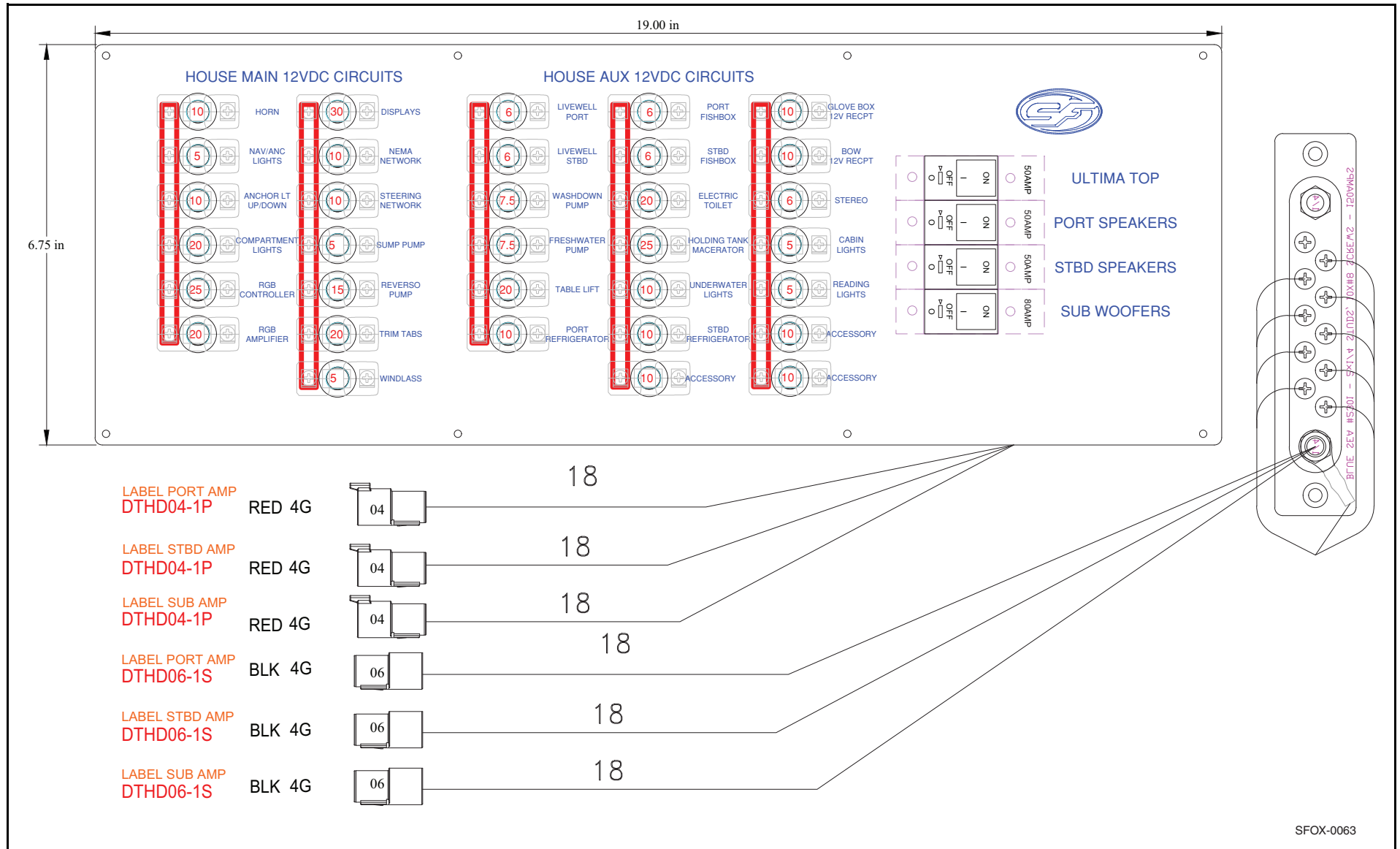

PANEL, MAIN DC DISTRIBUTION 2 OF 2

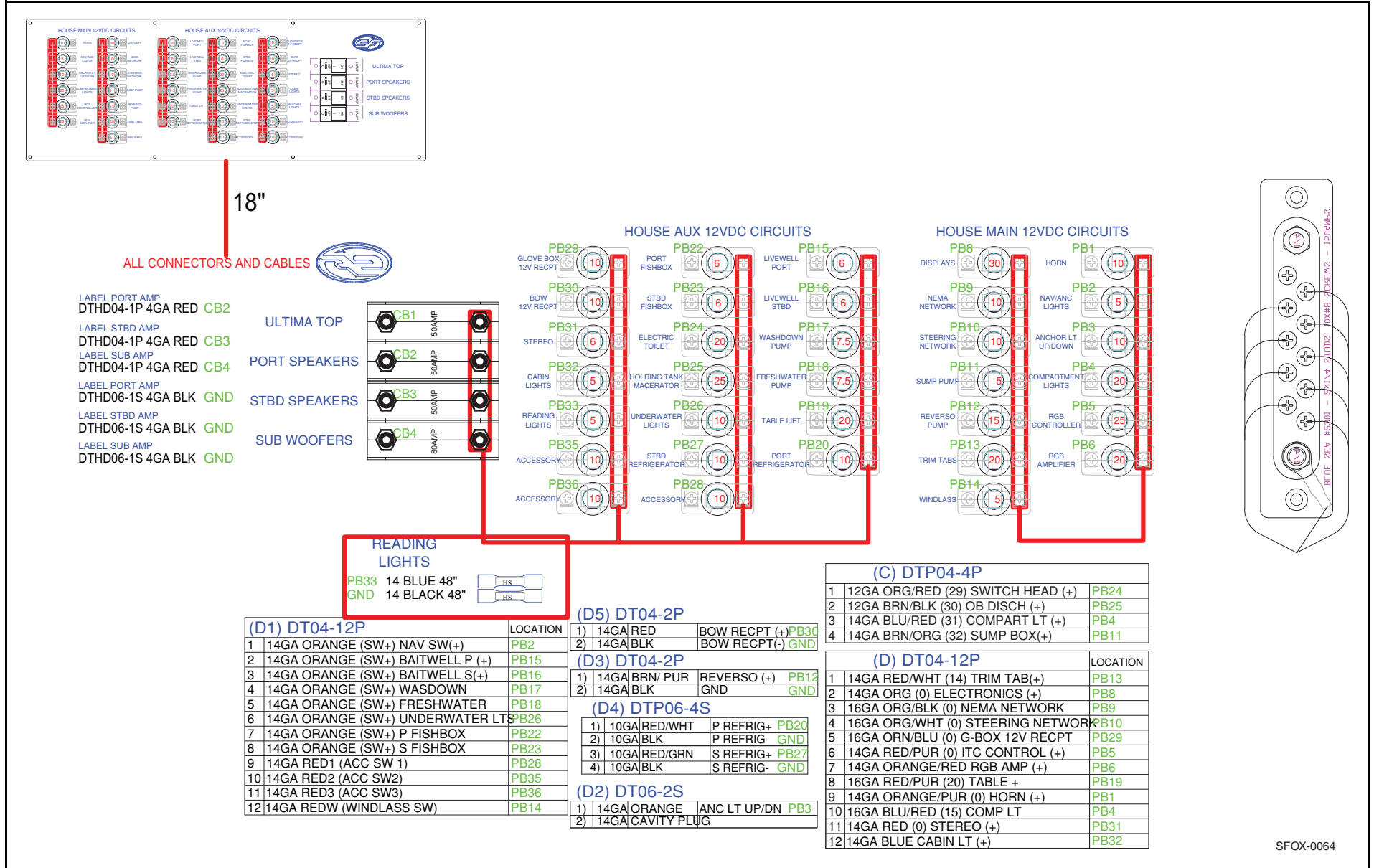

CABLE SET, TRIPLE ENGINE

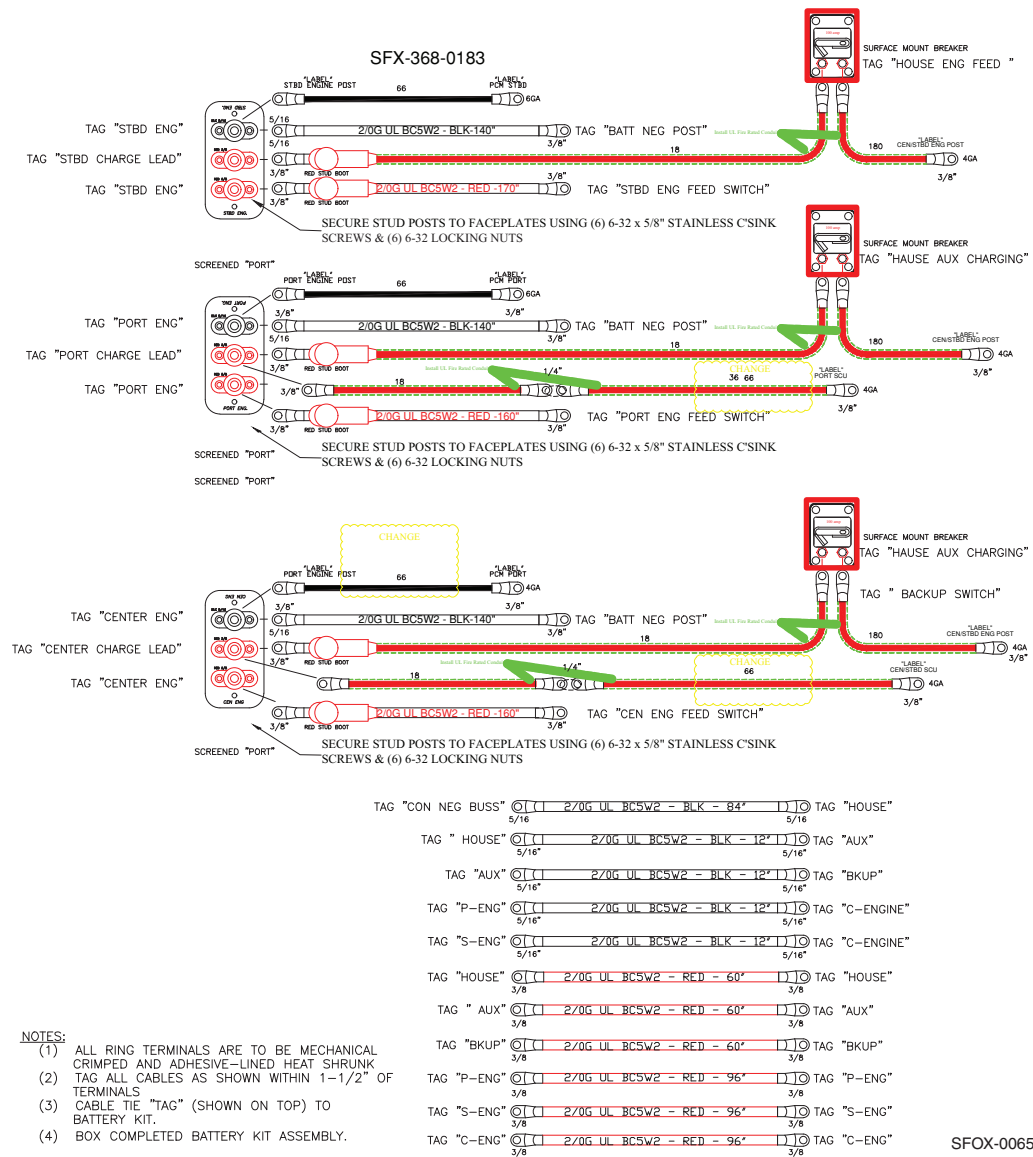

CABLE SET, TRIPLE ENGINE

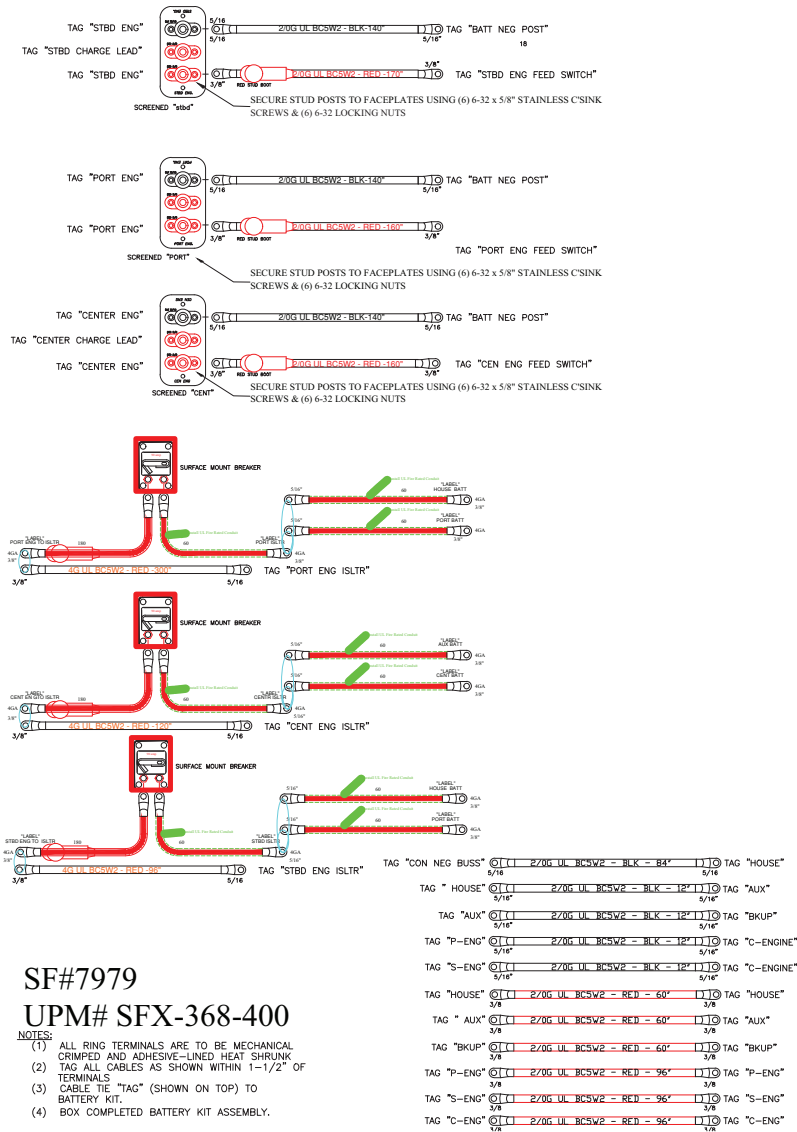

SF#7979

UPM# SFX-368-400

- NOTES:
- (1) ALL RING TERMINALS ARE TO BE MECHANICAL CRIMPED AND ADHESIVE-LINED HEAT SHRUNK TERMINALS
 - (2) TAG ALL CABLES AS SHOWN WITHIN 1-1/2" OF TERMINALS
 - (3) CABLE TIE "TAG" (SHOWN ON TOP) TO BATTERY KIT.
 - (4) BOX COMPLETED BATTERY KIT ASSEMBLY.

SFOX-0066

CABLE SET, TWIN ENGINE

SFX-368-0139

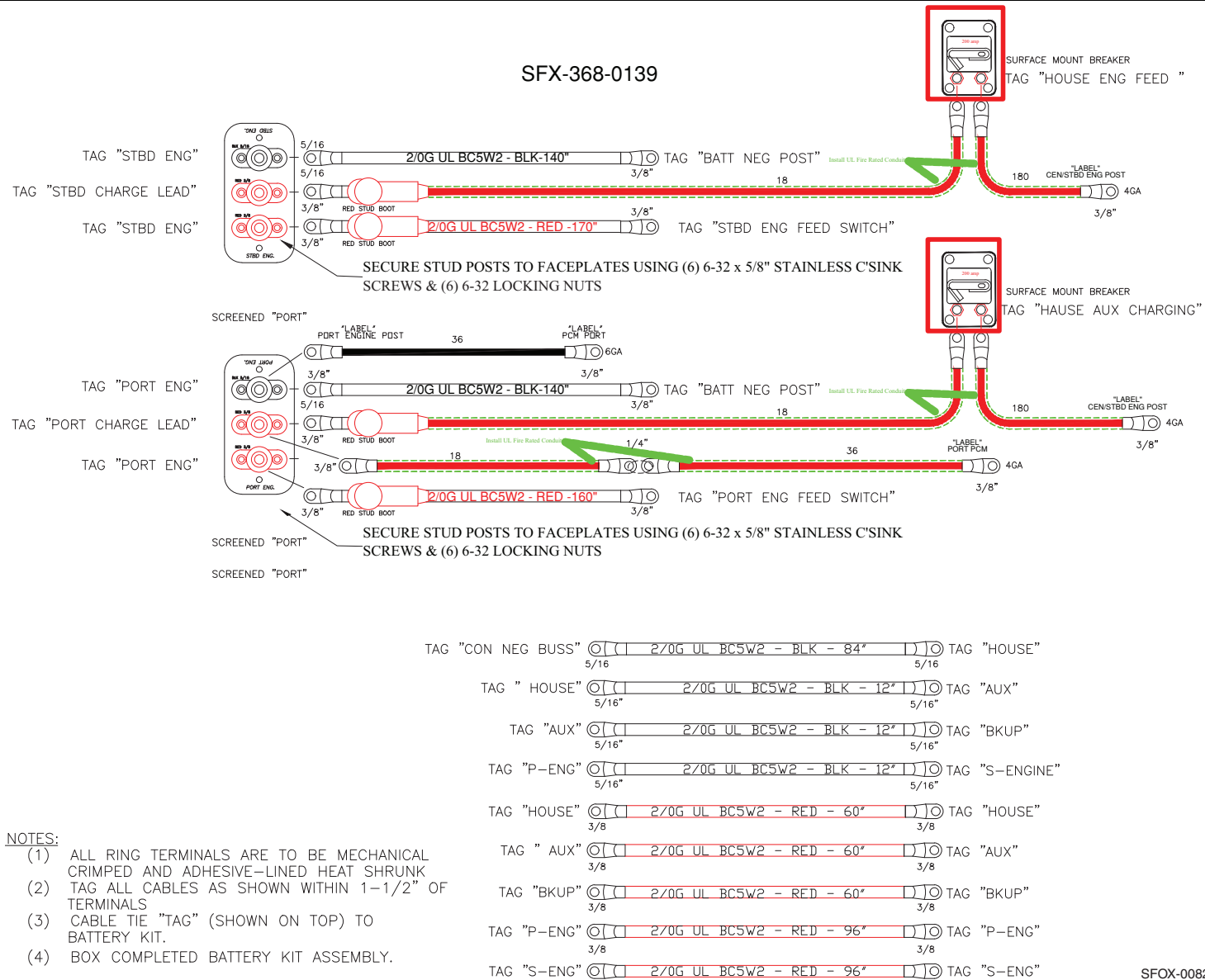

SFOX-0082

PANEL, GENERATOR, A/C, CHARGING SYSTEMS

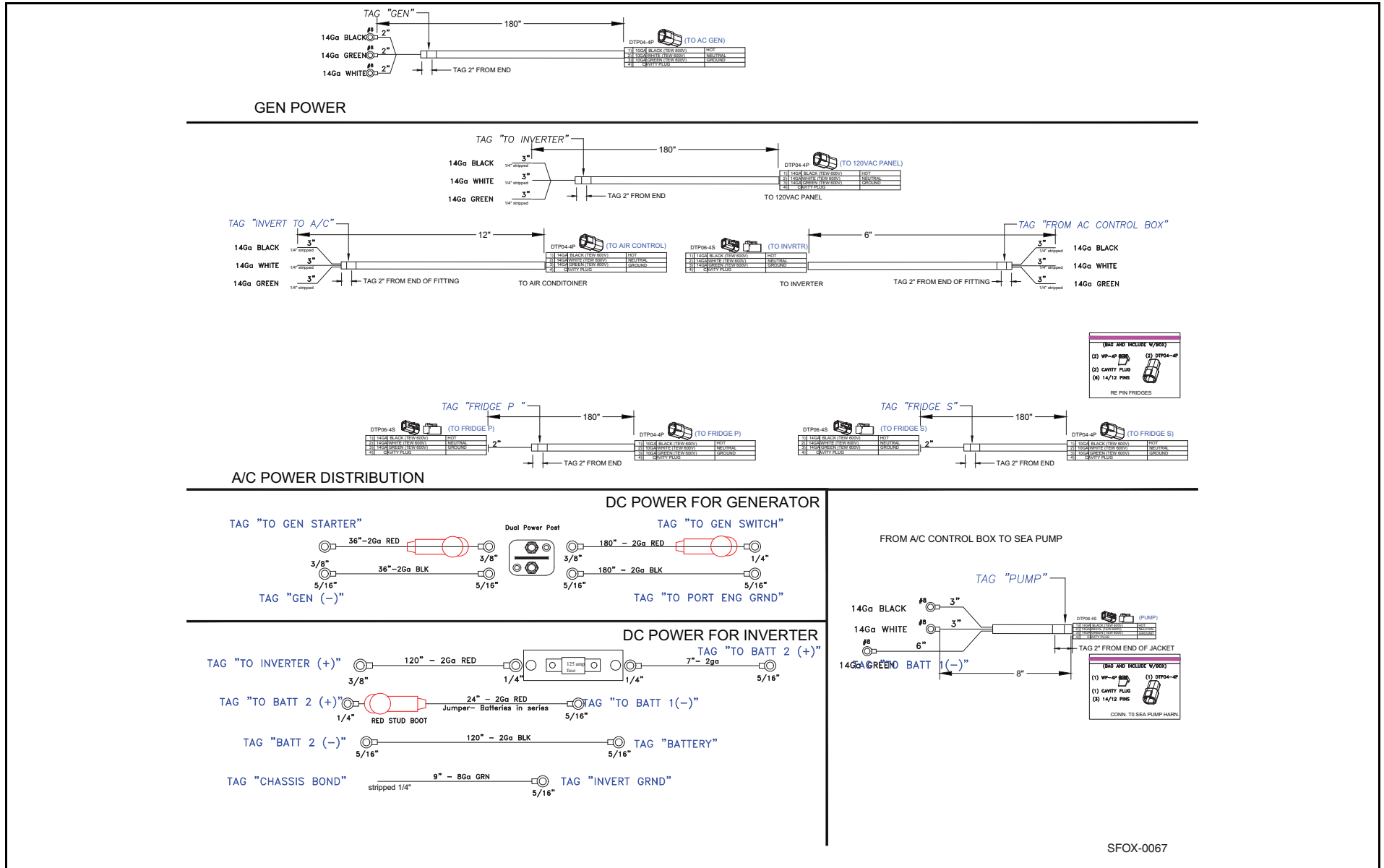

PANEL, GENERATOR, SHORE POWER, A/C, CHARGING SYSTEMS 1 OF 2

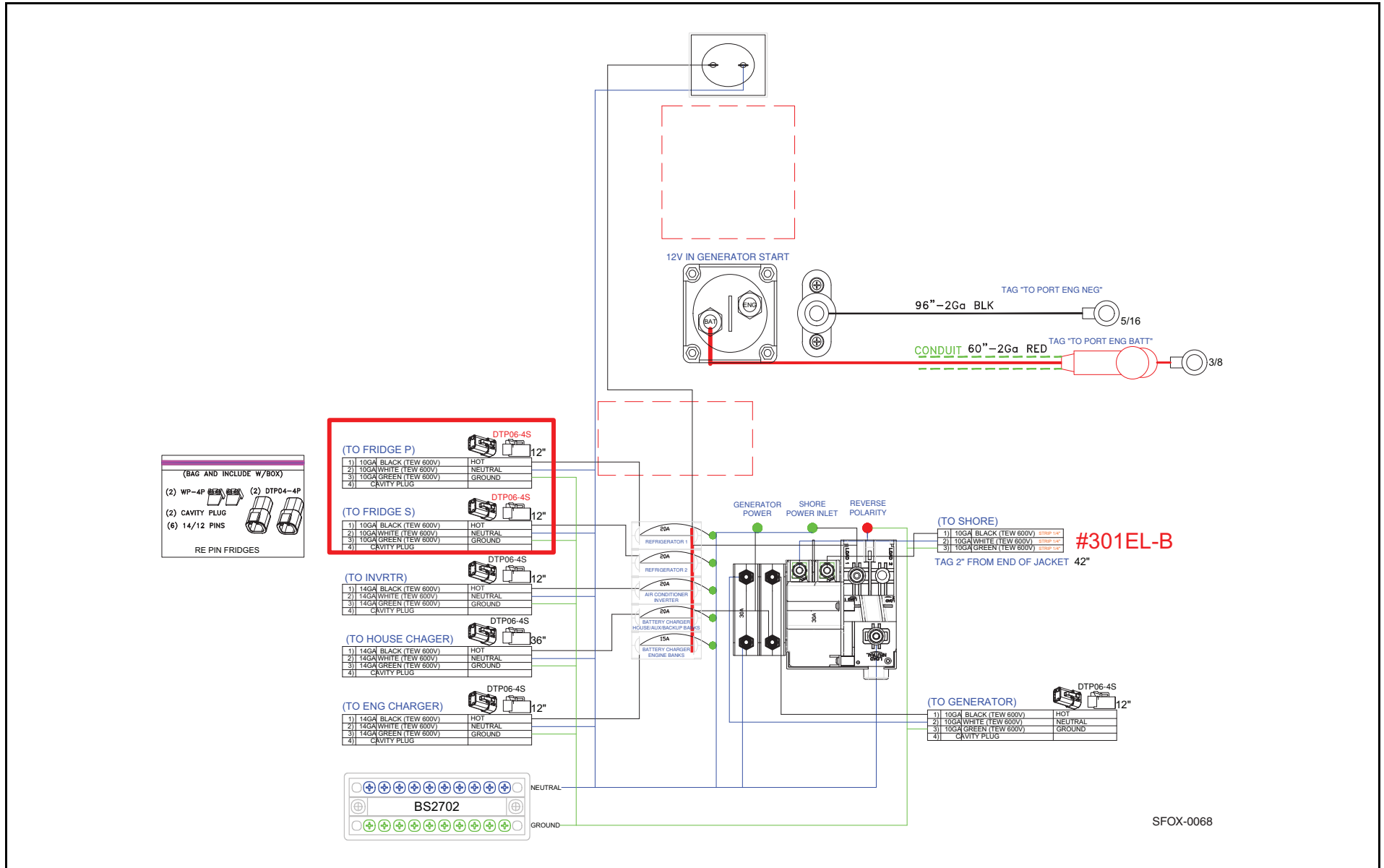

PANEL, GENERATOR, SHORE POWER, A/C, CHARGING SYSTEMS 2 OF 2

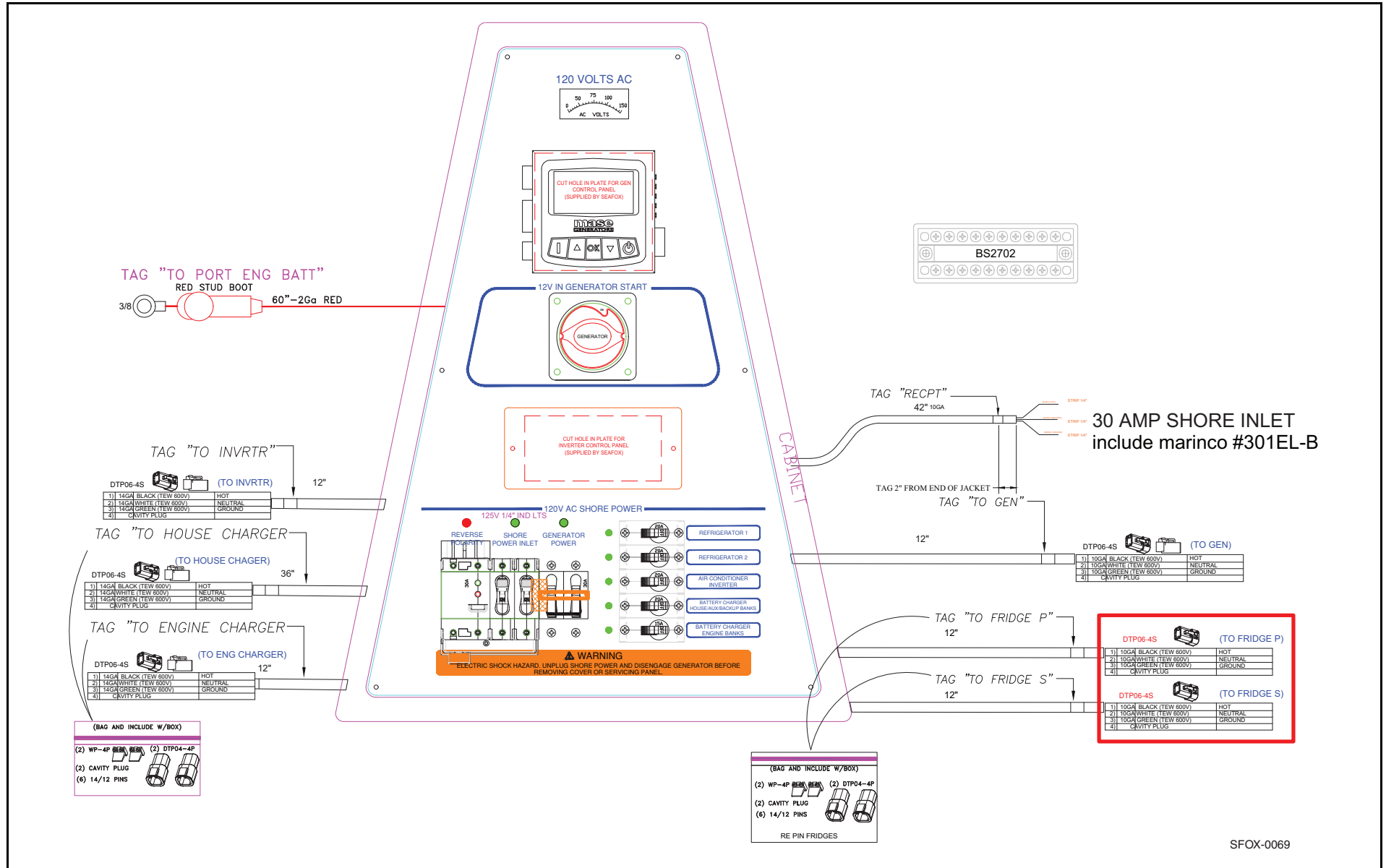

PANEL, SHORE POWER, A/C, CHARGING SYSTEMS 1 OF 3

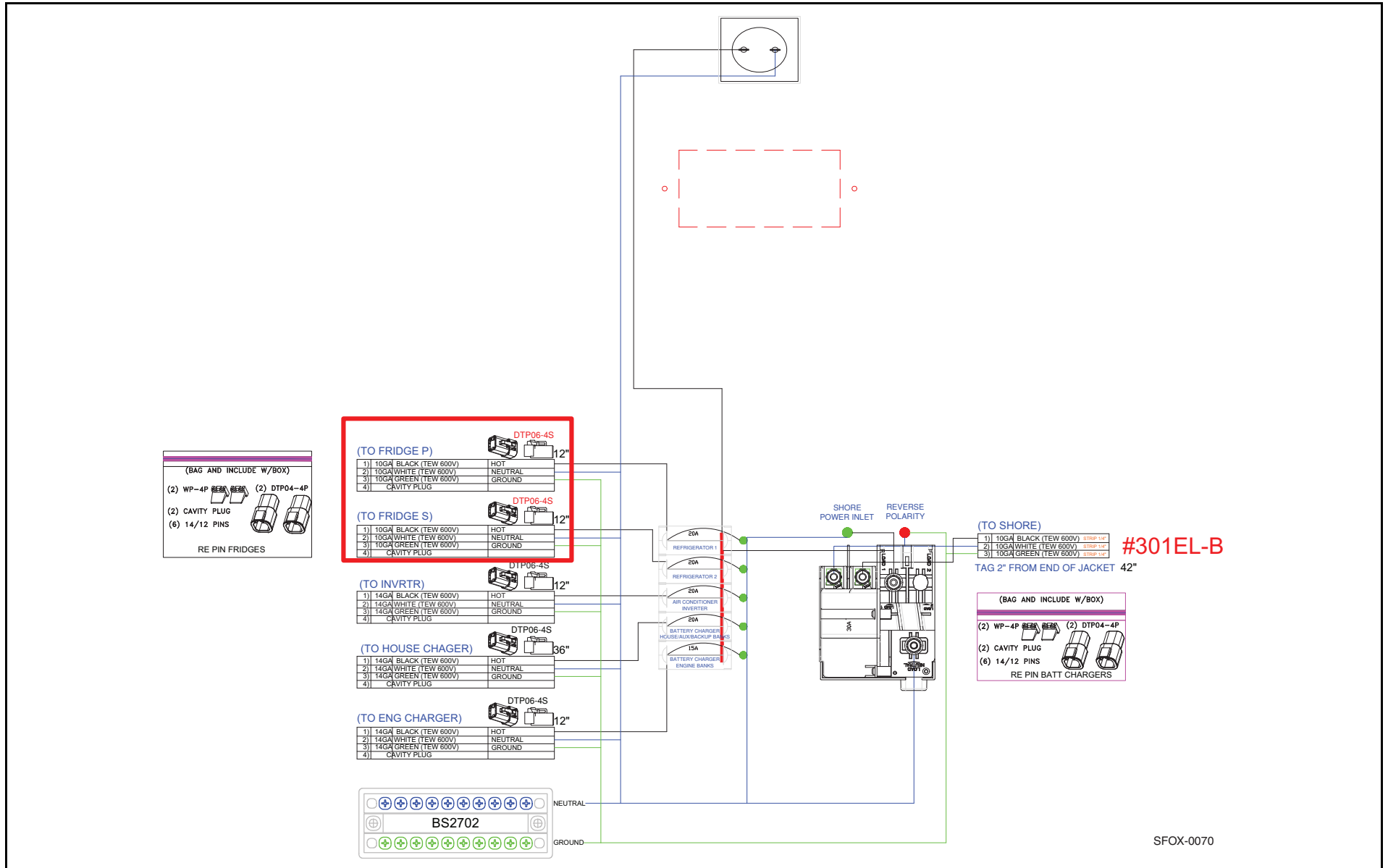

PANEL, SHORE POWER, A/C, CHARGING SYSTEMS 2 OF 3

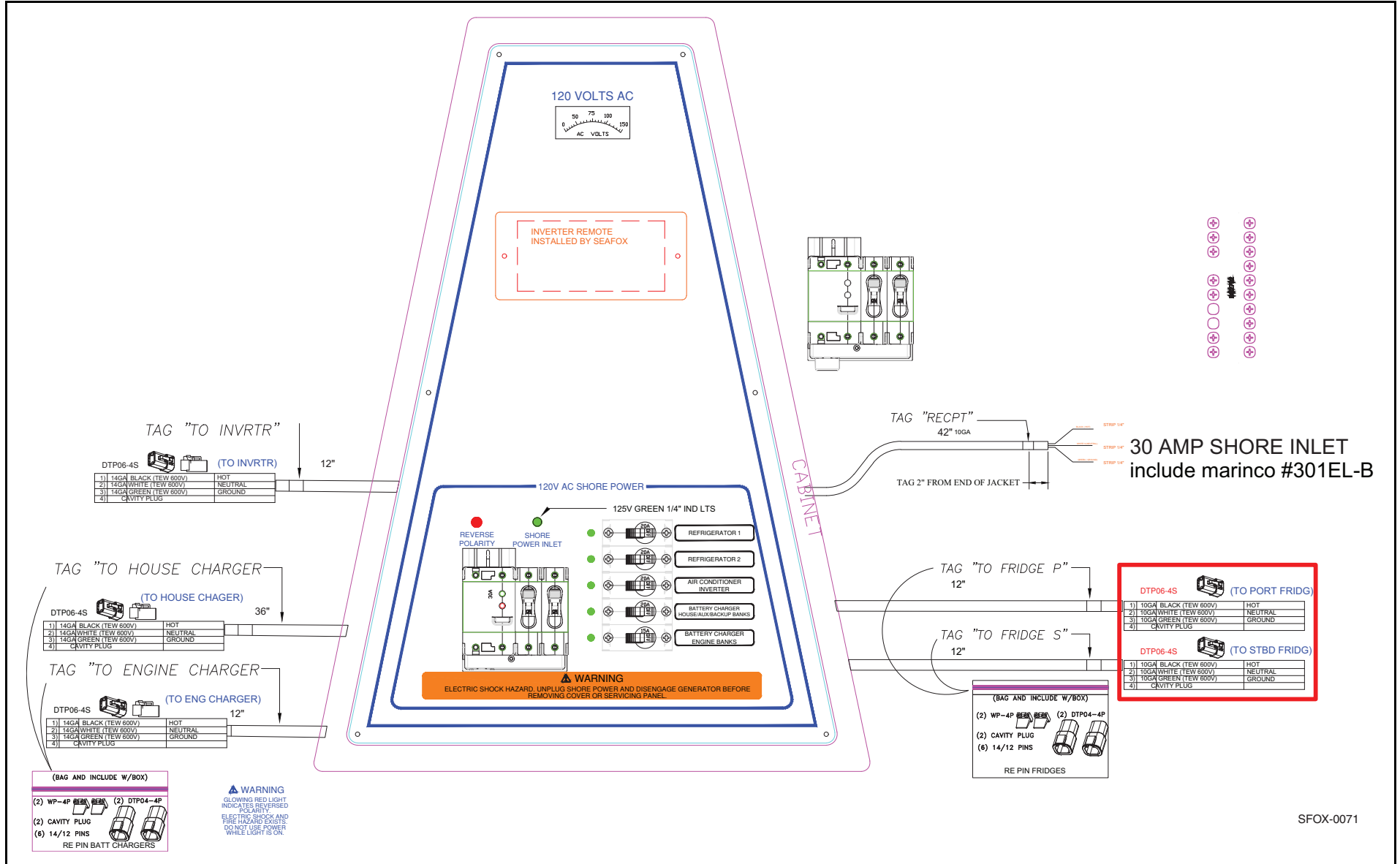

SFOX-0071

PANEL, SHORE POWER, A/C, CHARGING SYSTEMS 3 OF 3

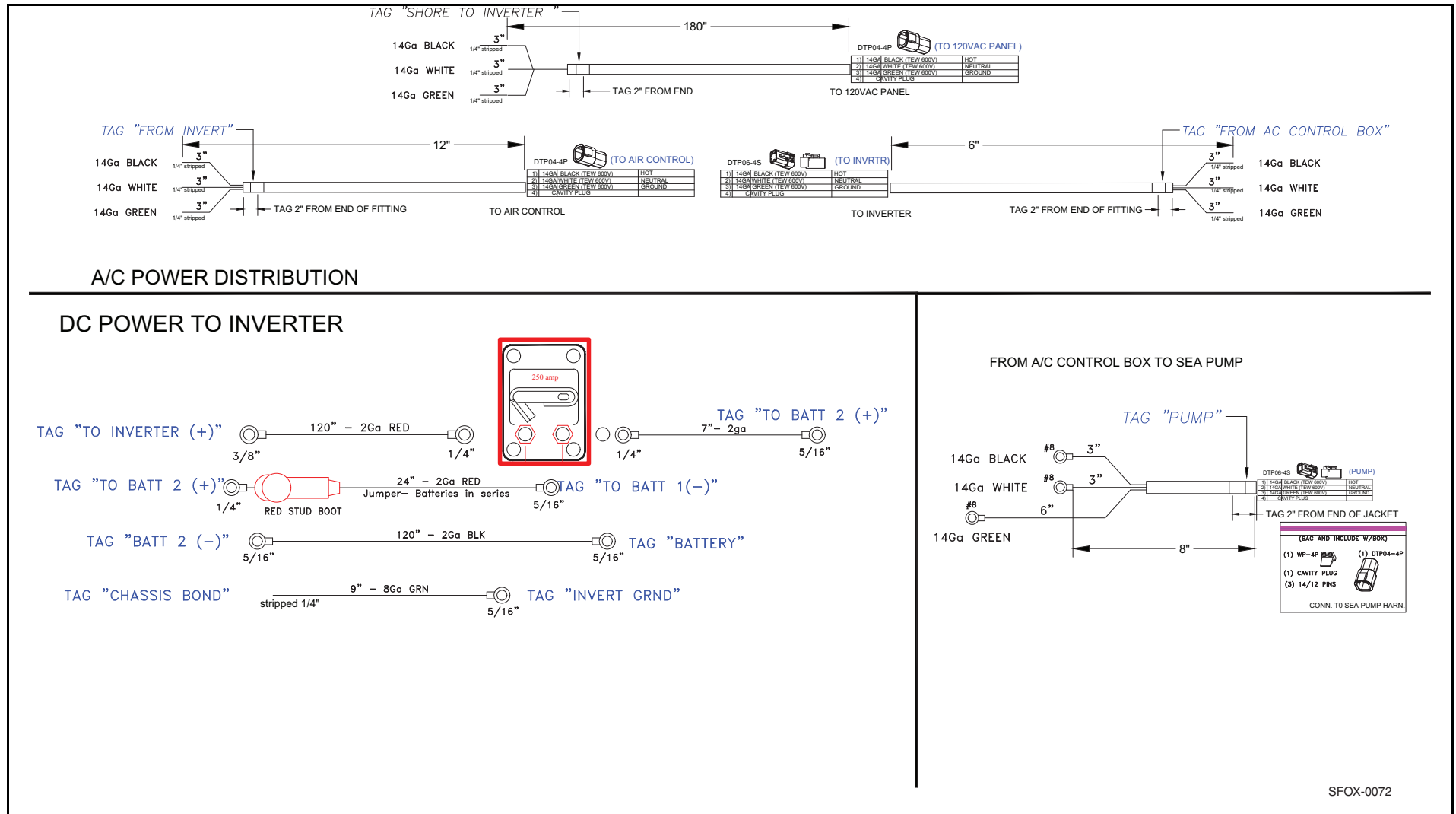

PANEL KIT, SEAKEEPER 3

*CABLES FROM SEAKEEPER TO PANEL ARE SUPPLIED BY SEAKEEPER

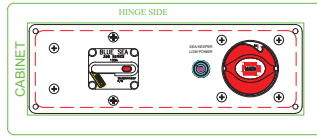

TAG "AUX-1" $\left[\begin{array}{c} \text{---} 2/0G \text{ UL BCSW2 - BLK - } 12' \text{ ---} \\ 5/16" \end{array} \right] \text{ TAG "AUX-2"}$
 TAG "AUX-1" $\left[\begin{array}{c} \text{---} 2/0G \text{ UL BCSW2 - RED - } 12' \text{ ---} \\ 3/8" \end{array} \right] \text{ TAG "AUX-2"}$

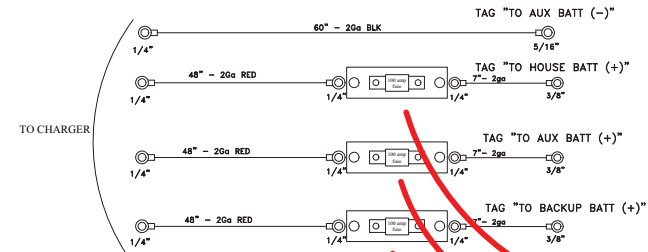
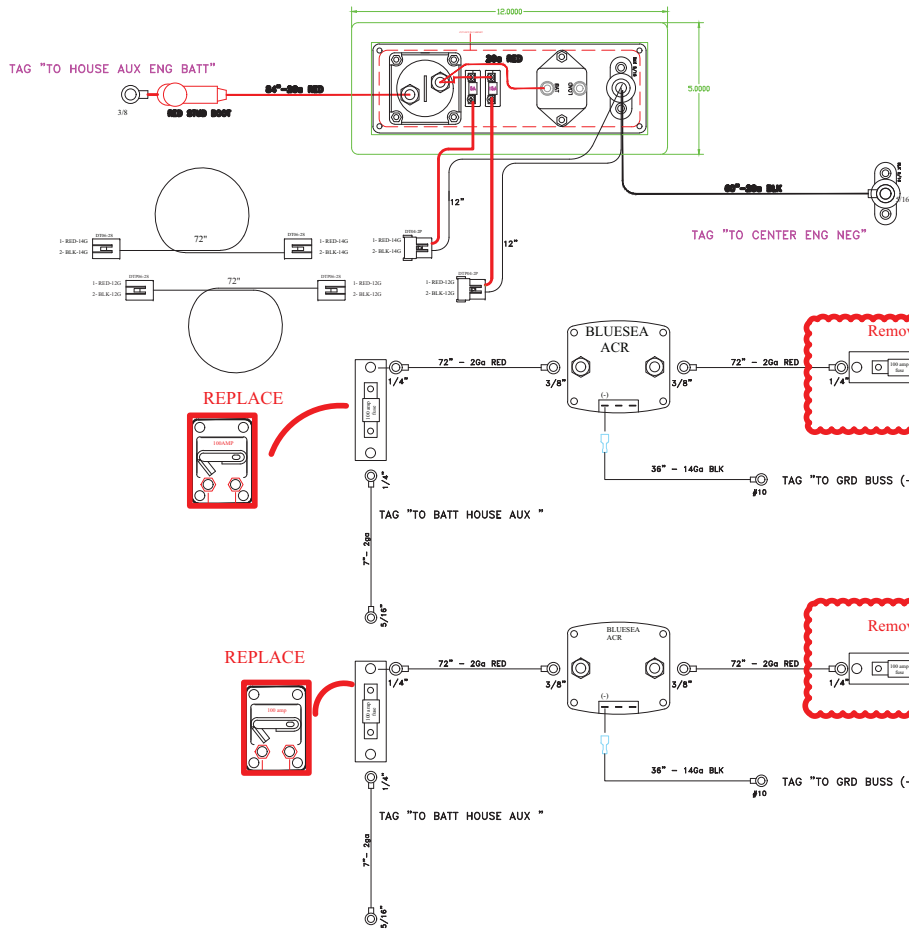

TAG "CHARGER-90AMP"

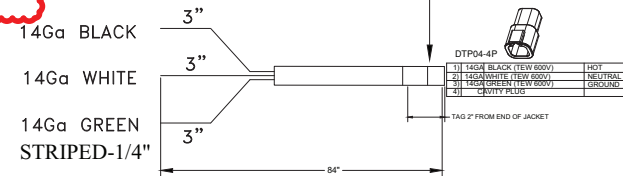

PANEL, HELM SWITCH 1 OF 2

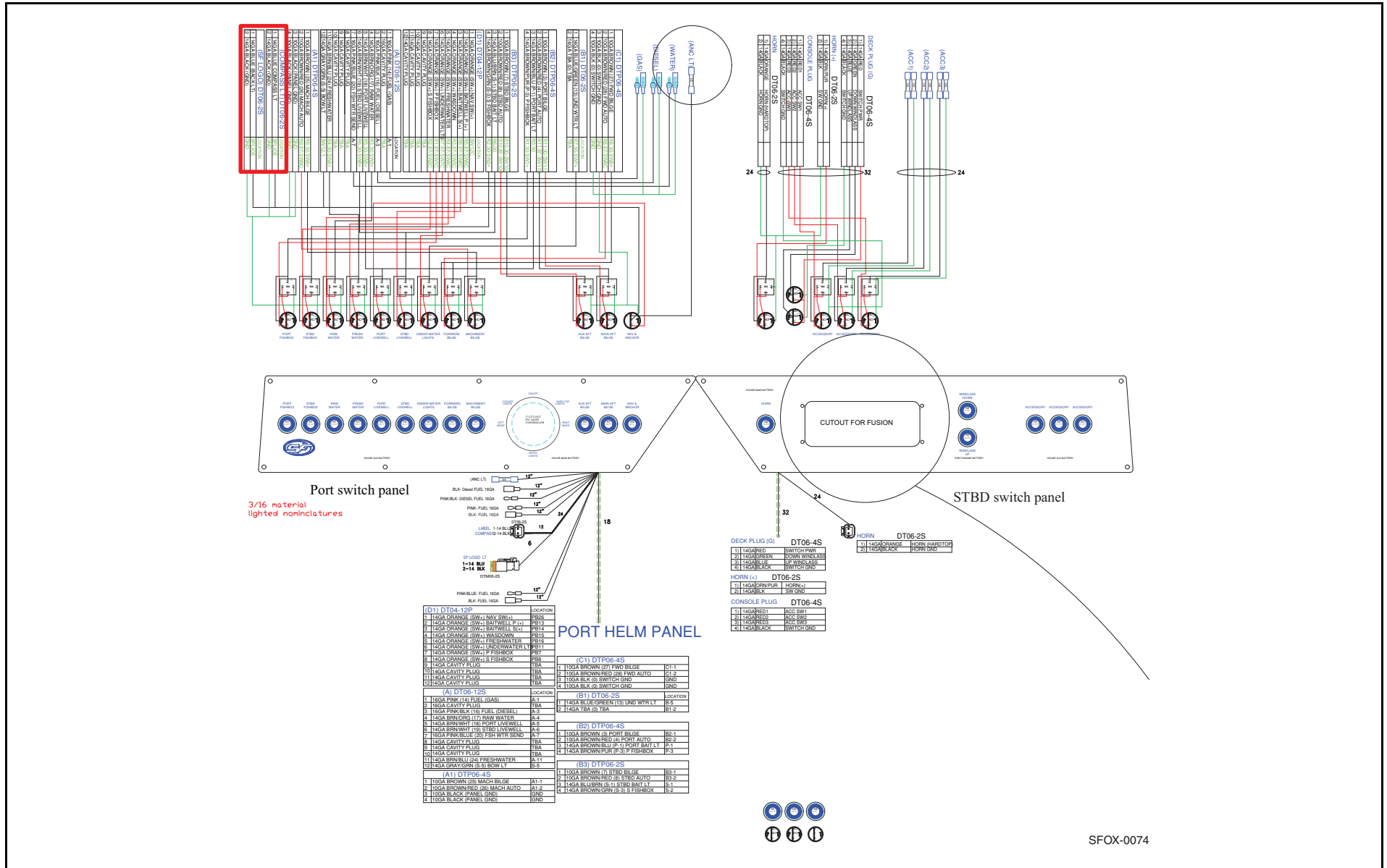

SFOX-0074

PANEL, HELM SWITCH 2 OF 2

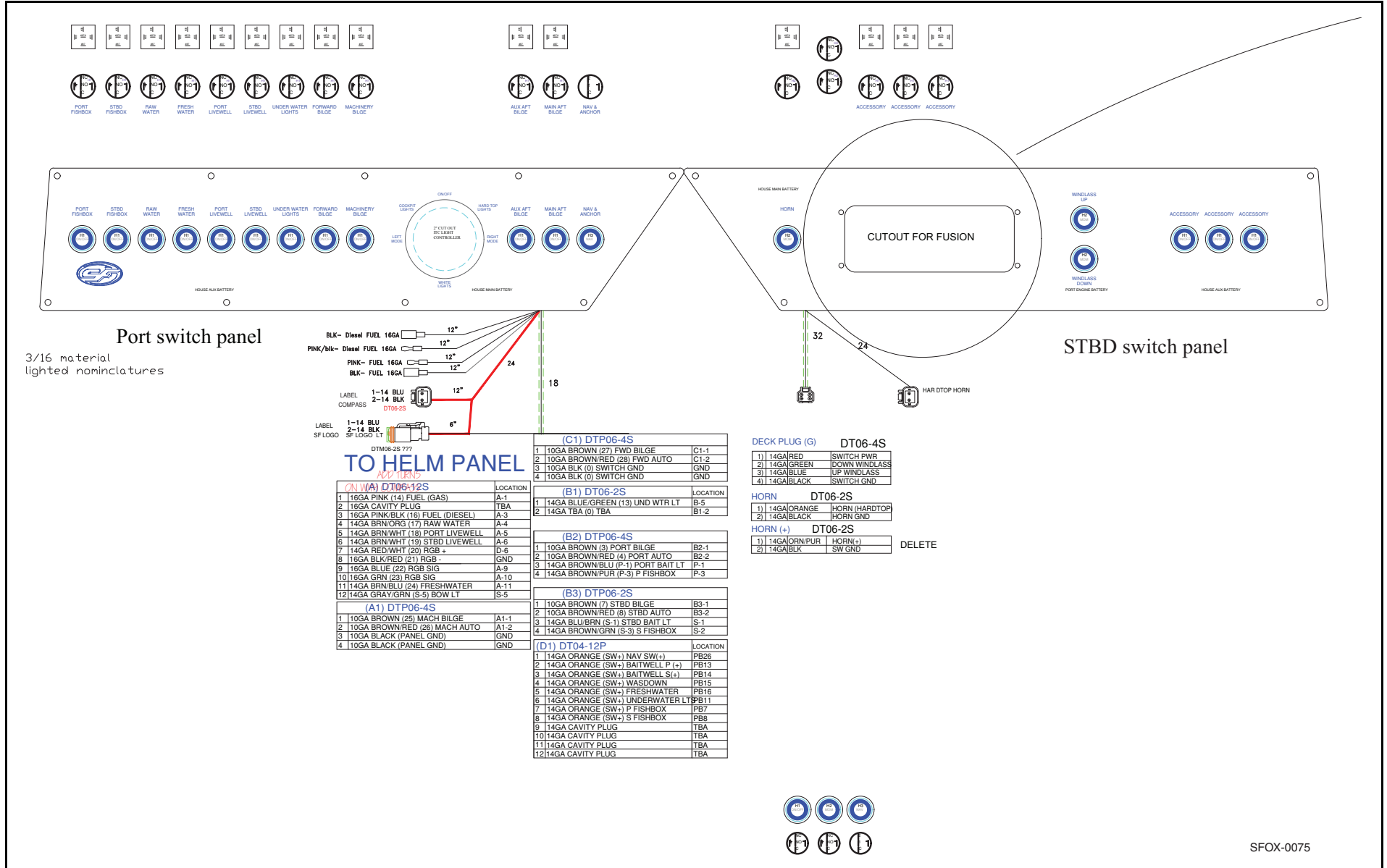

PANEL, BATTERY, TRIPLE 1 OF 2

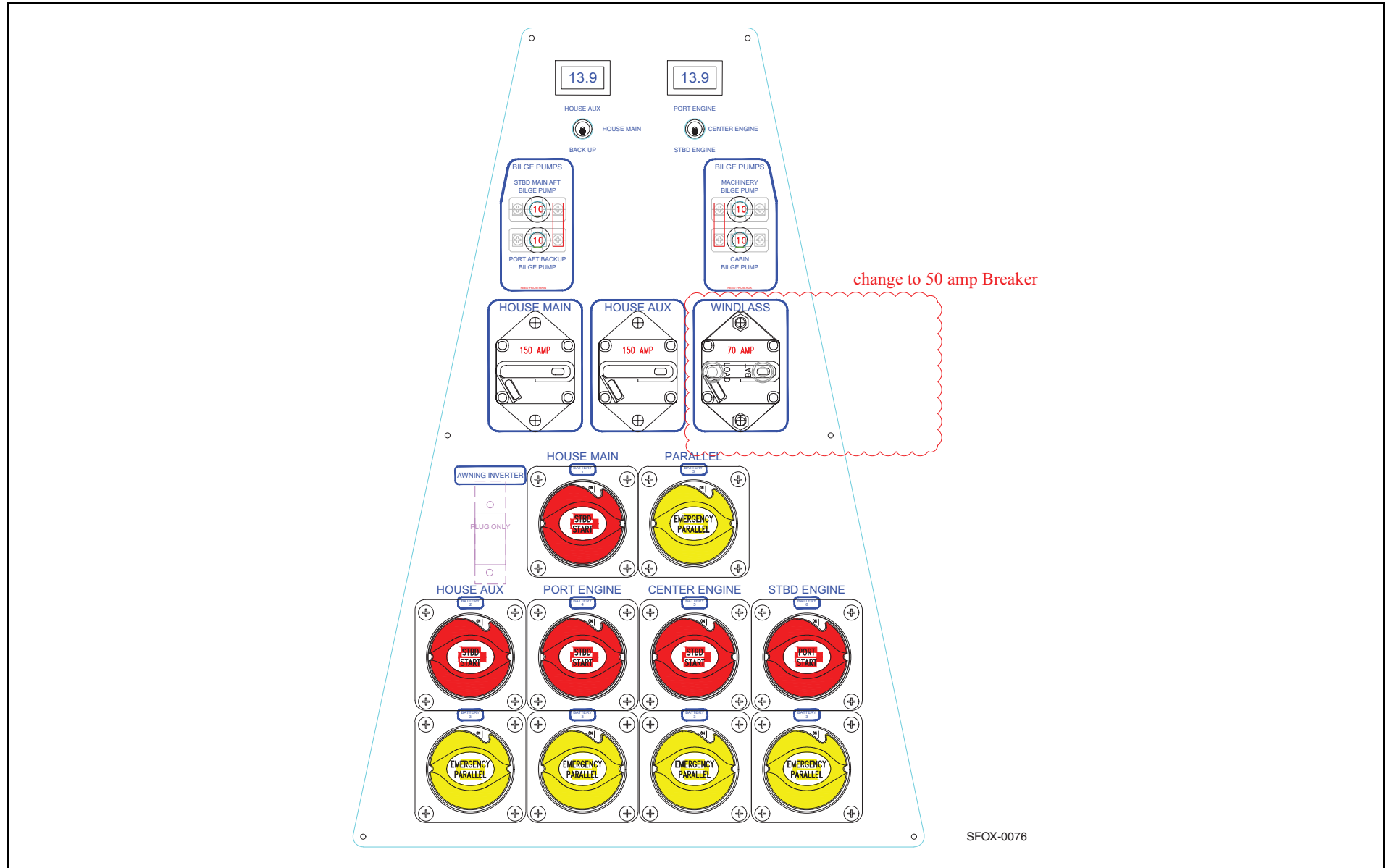

PANEL, BATTERY, TRIPLE 2 OF 2

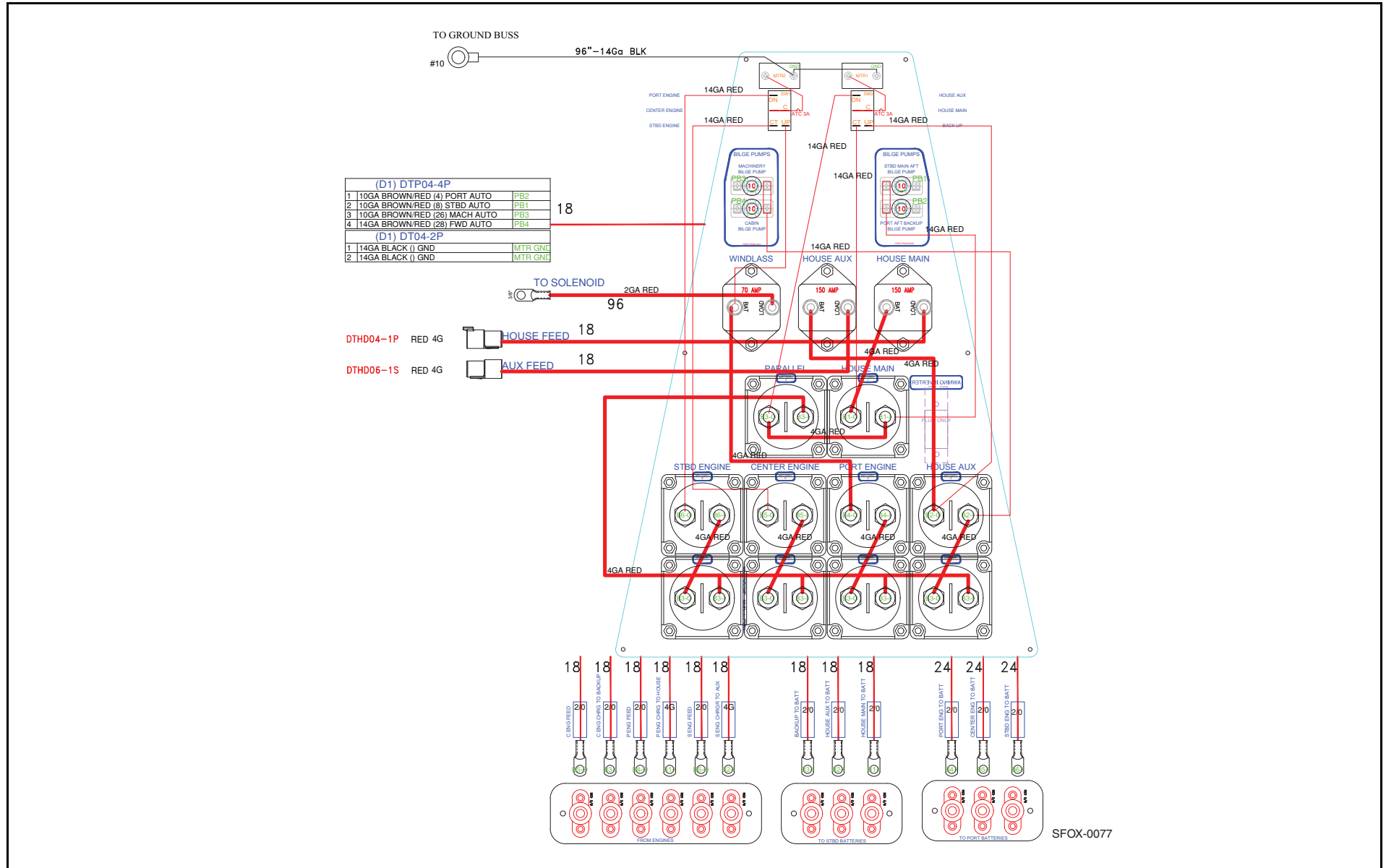

PANEL, BATTERY, TWIN 2 OF 2

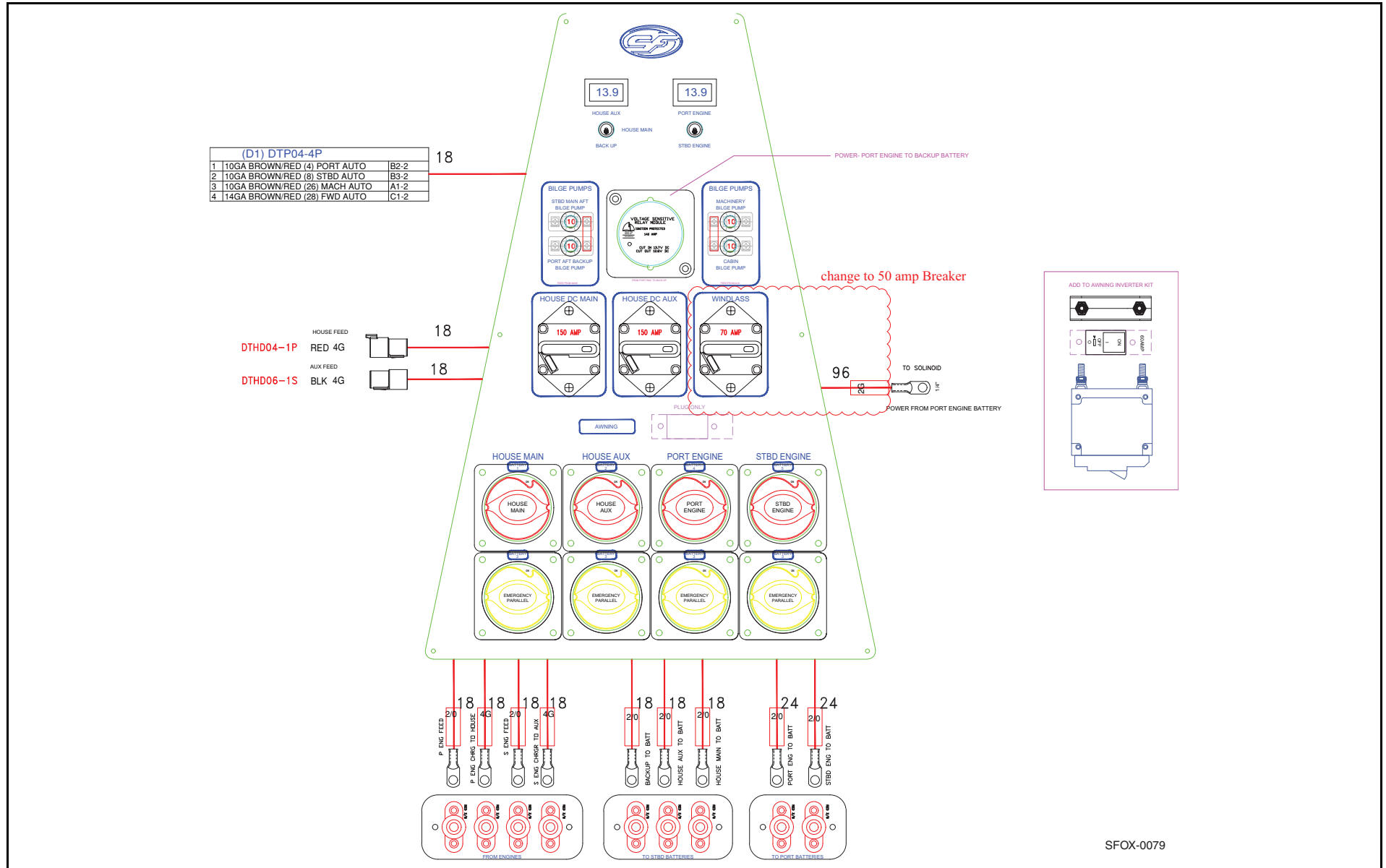

PIG TAIL, AMPLIFIER KIT

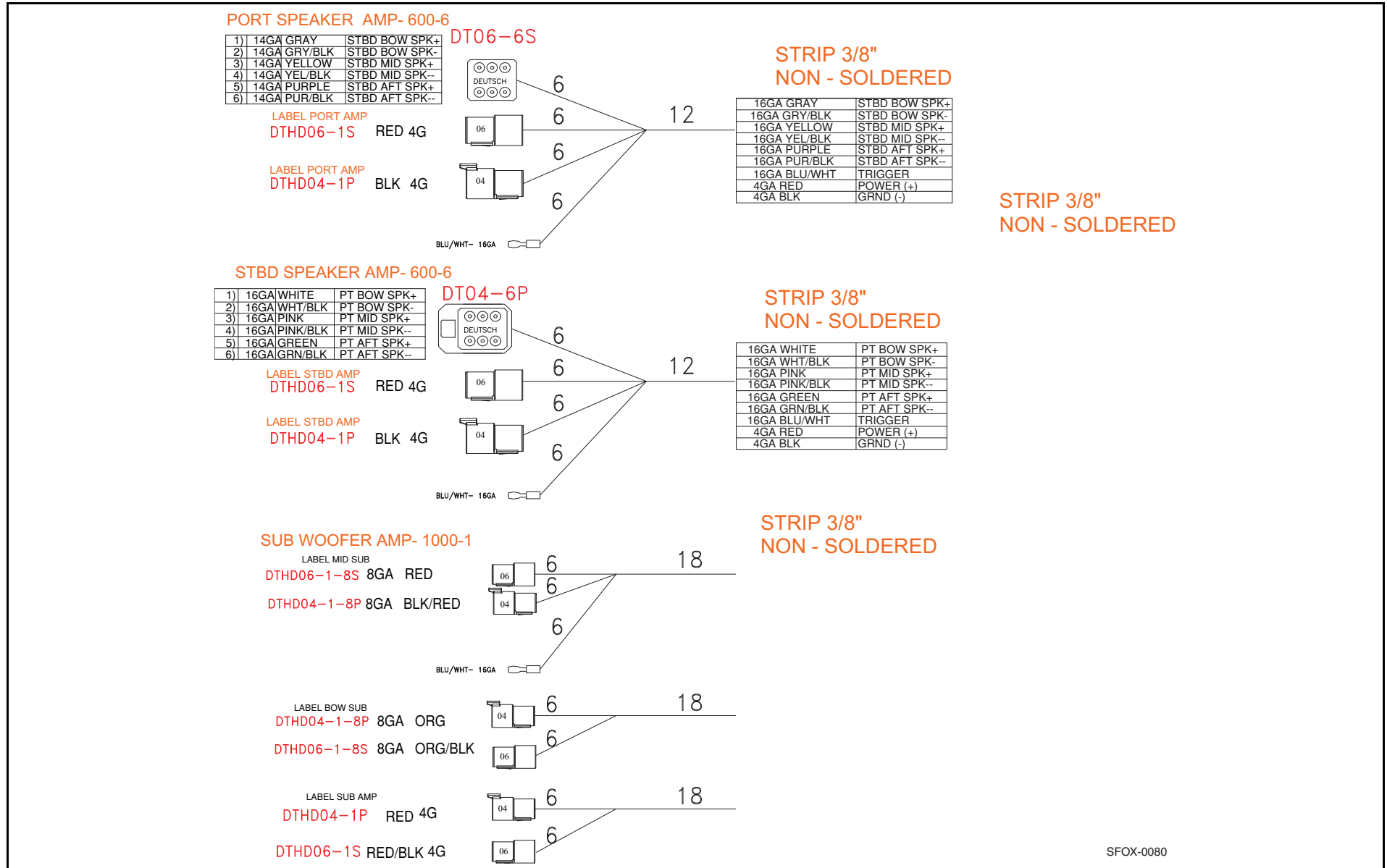

SEA FOX
BOAT WORKS

Sea Fox Boat Company, Inc.
2550 Highway 52
Moncks Corner, SC 29461-5024

Telephone: 843-761-6090
www.seafoxboats.com

Ken Cook Co.
Printed in U.S.A.
Rev 0224