

Z4ES



Owner's Manual Supplement

www.seafoxboats.com

SEA FOX BOAT'S DISCLAIMER

The following Owner's Manual is provided for information and educational purposes only and is not intended to offer or provide legal advice or create a contractual relationship between Sea Fox Boat Company and the owner of any Sea Fox brand vessel. Please beware that as a vessel owner you have non-delegable responsibilities regarding the safety, maintenance, fitness, and operation of your vessel and the extent of such responsibilities is ultimately determined by Federal law and regulations, the general maritime law of the United States, the laws and regulations of the states and territories of the United States, or the laws and regulations of the country where you operate your vessel. To fully understand your responsibilities as a vessel owner, and before operating or letting any third-party operate your vessel, we recommend that you consult the services of a qualified lawyer in admiralty and maritime law.

TABLE OF CONTENTS

Introduction	3	Panel Switch Deutsch (P/N 6114)	16
Specifications	3	Harness Liner w/ Kicker/Infin (P/N 6400)	17
Designated Occupant Seating	4	Harness ACC w/ Lenco Deutsch (P/N 6595)	18
Safety Decals	5	Trimtabs Electric Switch Standard (P/N 2895) – Optional	19
Plumbing Schematics	7	Harness Mood LT w/ Deutsch (P/N 6128) – Optional	20
Fresh Water System	7	Harness Stereo Infinity Con (P/N 6129) – Optional	21
Fuel System	8	Harness Underwater Lt w/ Deutsch (P/N 6133) – Optional	22
Livewell System	9	Harness Windlass Hull Aft Battery (P/N 6134) – Optional	23
Mister System	10	Harness Windlass Deck Option (P/N 6135) – Optional	24
Raw Water System	11	Electric Flush-Discharge Switch Panel (P/N 6136) – Optional	25
Waste System	12	U Panel Switch Ultima (P/N 6463) – Optional	26
Bilge System	13	Center Console Ultima Top – 2016 (P/N 6463, 6464 and 6476) – Optional	27
Drains	14	Electric Flush Switch Panel (P/N 6870) – Optional	28
Electrical Schematics	15	Head Harness ORB 249AV (P/N 6871) – Optional	29
Typical 2-Battery Setup with Transom	15		

This Page Intentionally Left Blank

INTRODUCTION

Congratulations and Welcome Aboard! With so many boat brands to choose from, we want to congratulate you on your decision to choose Sea Fox Boats. For more than 24 years, Sea Fox offers the finest hand-crafted saltwater boats carefully balanced with the build-quality, features, styling and performance for the fairest price. Our passion for boating is evident in every model we make and we appreciate that you've noticed the Sea Fox difference.

We share your love for the moments spent on the water with friends and family, which is why every Sea Fox boat offers a unique blend of fishing/family options, technologies and innovative features. Your choice of a Sea Fox affirms that you have performed your research and compared the value of your model with the competition.

Whether you are new to the boating lifestyle or an old salt, we ask that **you and all other operators** read the owner's manual, this supplement, and all other literature provided with the boat **before** operating the boat or any equipment. We also recommend that all operators enroll in a boating safety course available online - see References and Contact Information in this section for education resources online.

This supplement contains model-specific information not included with the owner's manual. This manual is not intended to be a replacement for specific product literature provided by engine, accessory or other major equipment manufacturers, but rather to supplement that information.

Because of our philosophy of continuous product improvement, this manual serves as a general guide only, so the specifications and illustrations used may not match the equipment on your boat and are intended only as general reference views.

We welcome you to the Sea Fox family and wish you many years of boating enjoyment!

SPECIFICATIONS

Max. Weight Capacity	2500 lbs (1134 kg)
Persons	10
Persons Weight	1500 lbs (680 kg)
Max. HP	300 hp (224 kw)
L.O.A.	24' 4" (7.41 m)
Beam	8' 6" (2.59 m)
Draft	14 in. (0.36 m)
Height, Keel to Top (Light Folded)	115 in. (2.92 m)
Bridge Clearance Hard Top	99 in. (2.51 m)
Max. Weight Boat (w/ Fluids, Largest HP)	5146 lbs (2334 kg)
Fuel Tank Capacity	117 gal (443 L)
Freshwater Tank Capacity	12 gal (45 L)
Holding Tank Capacity	12 gal (45 L)

DESIGNATED OCCUPANT SEATING

Be sure all passengers are properly seated in designated seating positions and not riding on the bow, bow pulpit, deck, gunwale or rear sun deck while underway. Passengers must use hand-holds and use caution when riding in the bow. Move to the aft passenger seats during rough water operation or if visibility is restricted.

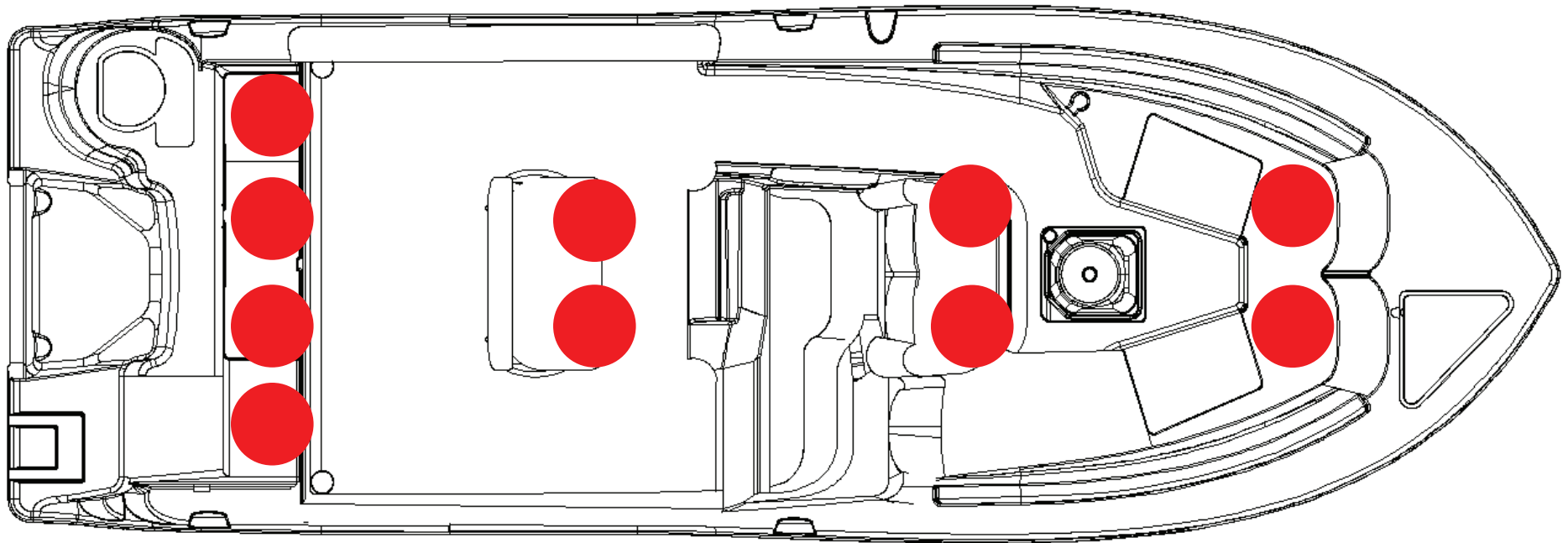

● = Seat position

SFOX-0023

SAFETY DECALS



7

6

WARNING
 Moving parts can crush and cut.
 Keep hands clear while operating bracket.
 U336076-01

6

FRESH WATER
 U336079-01

6

RAW WATER
 U336079-01

4

Manufactured by
SEA FOX
 BOAT WORKS

5

WARNING
**AVOID PERSONAL INJURY
 SECURE GATE
 WHEN BOAT IS UNDERWAY**
 U336070-01

3

WARNING
 Improper stove burner refueling practices can result in fire and/or explosion. To avoid severe injury or death from fire or explosion, follow the stove manufacturer's instructions for refilling burner, and

- turn the stove burner off before refueling;
- remove the container from stove;
- fill the fuel container away from stove.

U336071-01

7

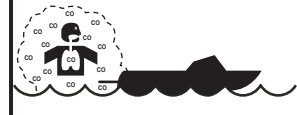
DANGER

 Carbon monoxide (CO) can cause brain damage or death.
 Engine and generator exhaust contains odorless and colorless carbon monoxide gas.
 Carbon monoxide will be around the back of the boat when engines or generators are running.
 Move to fresh air, if you feel nausea, headache, dizziness, or drowsiness.
 U336068-01

7

**NO WOOD!
 NO ROT!**
 U336062-01

4

MAXIMUM CAPACITIES
10 PERSONS OR 1500 LBS.
 2500 LBS. PERSONS, MOTOR, GEAR
 300 H.P. MOTOR
 THIS BOAT COMPLIES WITH THE U.S. COAST GUARD SAFETY STANDARDS IN EFFECT ON THE DATE OF CERTIFICATION
 SEA FOX BOAT COMPANY, INC.
 MONCK'S CORNER, S.C. MS13A
 U336087-01

6

WARNING
 Failure to follow these warnings could cause **SERIOUS INJURY** or **DEATH**.

- **REMAIN PROPERLY SEATED AND HOLD ON** to available handrails while boat is moving to avoid falling overboard or being ejected from the boat. Do not sit on seat backs, gunwales or outermost deck edges.
- **WEAR U.S. COAST GUARD APPROVED LIFE JACKETS.** 
- **DO NOT OVERLOAD THE BOAT. OCCUPANTS AND GEAR MUST BE PROPERLY AND EVENLY DISTRIBUTED** fore and aft, and on both sides of the boat. Improper loading and/or overloading may result in poor handling, sudden loss of control, swamping and/or capsizing.
- **REFER TO AND OBEY THE DESIGNATED OCCUPANT SEATING POSITIONS** that are indicated by the manufacturer for your specific model.
- **OBEY THE OPERATOR** at all times.
- **DO NOT RESTRICT THE OPERATOR'S VISION.**
- **DO NOT DEPART THE VESSEL** without informing the operator.

3

NON POTABLE WATER
 U336077-01

6

NON POTABLE WATER
 U336077-01



2

WARNING
 CONTENTS CAN BE UNDER PRESSURE. AVOID SERIOUS INJURY OR DEATH FROM FIRE OR EXPLOSION. OPEN SLOWLY IN WELL VENTILATED AREA. NO SMOKING OR OPEN FLAMES.
GAS / PETROL ONLY

 U336088-01

4

WARNING

ROTATING PROPELLER CAN CAUSE SERIOUS INJURY OR DEATH. SHUT OFF MOTOR WHEN NEAR PERSONS IN WATER.
 U338129-01

4

WARNING

 Rotating propeller may cause serious injury or death. Shut off engine when near persons in the water.

 Carbon monoxide (CO) can cause brain damage or death. Engine and generator exhaust contains odorless and colorless carbon monoxide gas. Signs of carbon monoxide poisoning include nausea, headache, dizziness, drowsiness, and lack of consciousness. Get fresh air if anyone shows signs of carbon monoxide poisoning. See Owner's Manual for information regarding carbon monoxide poisoning.

 Leaking fuel is a fire and explosion hazard.
 • Avoid serious injury or death from fire or explosion from leaking fuel. Inspect system for leaks at least once a year.
 U336074-01
SEA FOX BOAT COMPANY
 MEETS U.S. EPA EVAP STANDARDS USING CERTIFIED COMPONENTS

4

WARNING
 Operating, servicing and maintaining a recreational marine vessel can expose you to chemicals including engine exhaust, carbon monoxide, phthalates, and lead, which are known to the State of California to cause cancer and birth defects or other reproductive harm. To minimize exposure, avoid breathing exhaust, service your vessel in a well-ventilated area and wear gloves or wash your hands frequently when servicing this vessel. For more information go to www.P65warnings.ca.gov/marine.
 U338438-01

1

WARNING
 Failure to follow these warnings could cause **SERIOUS INJURY** or **DEATH**.

- **REMAIN PROPERLY SEATED AND HOLD ON** to available handrails while boat is moving to avoid falling overboard or being ejected from the boat. Do not sit on seat backs, gunwales or outermost deck edges.
- **WEAR U.S. COAST GUARD APPROVED LIFE JACKETS.** 
- **DO NOT OVERLOAD THE BOAT. OCCUPANTS AND GEAR MUST BE PROPERLY AND EVENLY DISTRIBUTED** fore and aft, and on both sides of the boat. Improper loading and/or overloading may result in poor handling, sudden loss of control, swamping and/or capsizing.
- **REFER TO AND OBEY THE DESIGNATED OCCUPANT SEATING POSITIONS** that are indicated by the manufacturer for your specific model.
- **OBEY THE OPERATOR** at all times.
- **DO NOT RESTRICT THE OPERATOR'S VISION.**
- **DO NOT DEPART THE VESSEL** without informing the operator.

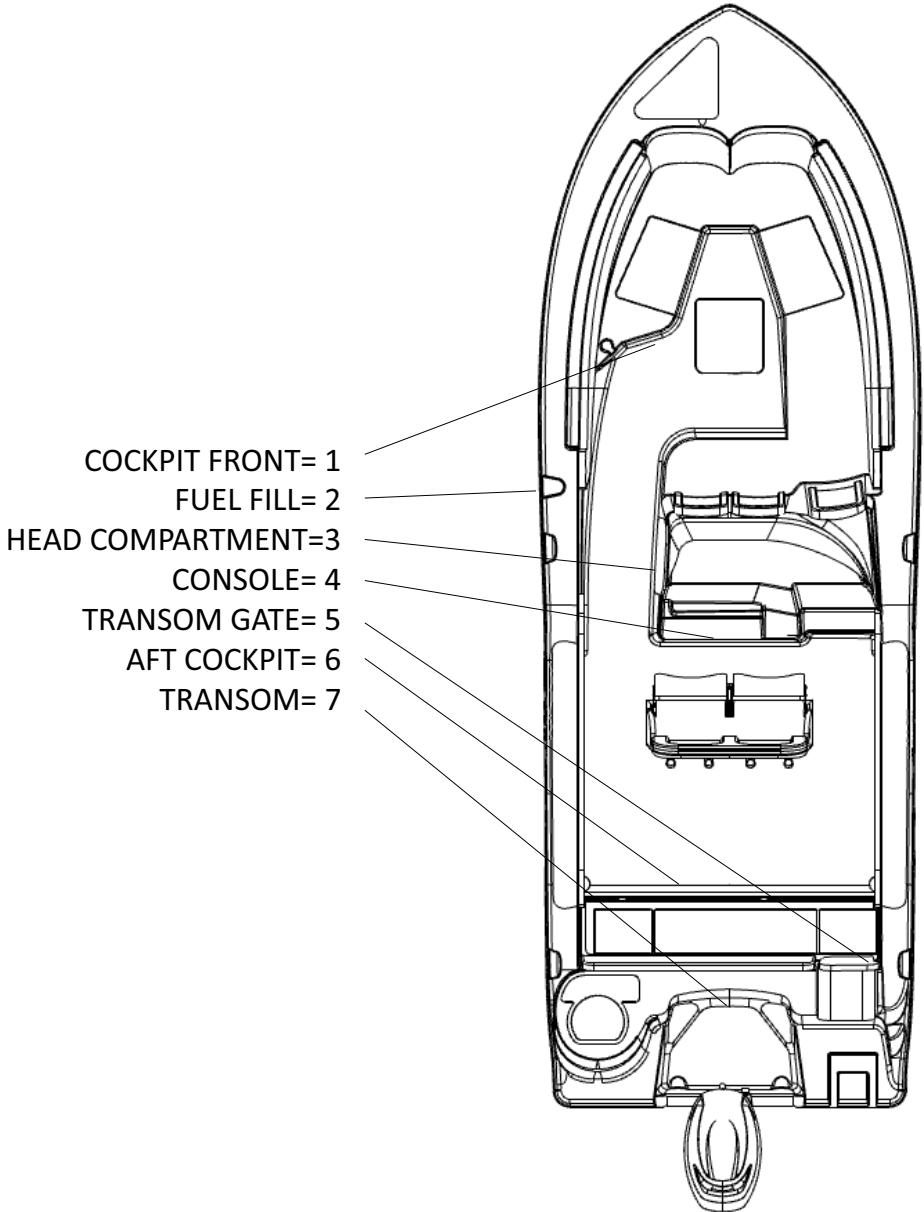

PLUMBING SCHEMATICS

FRESH WATER SYSTEM

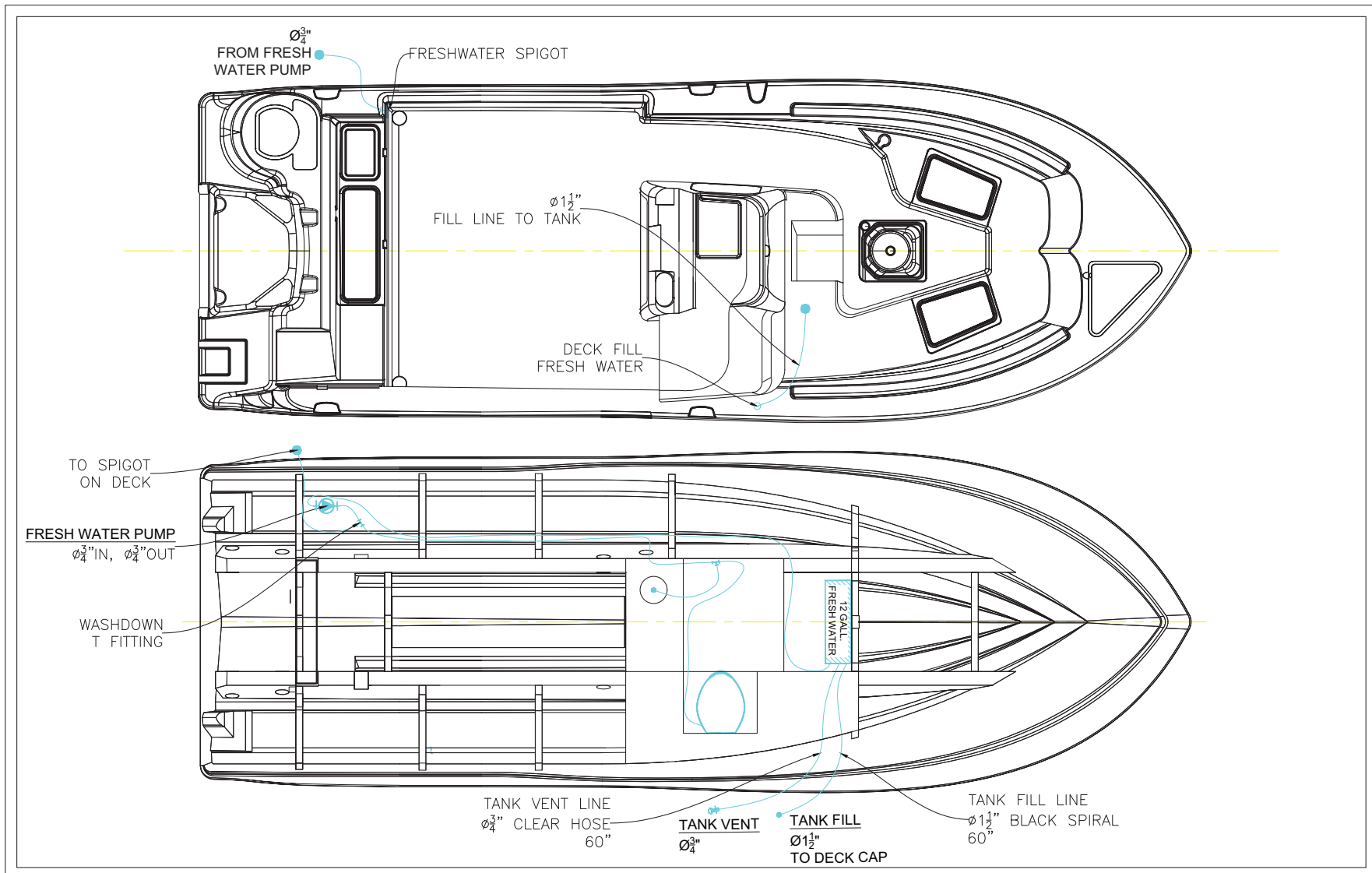

FUEL SYSTEM

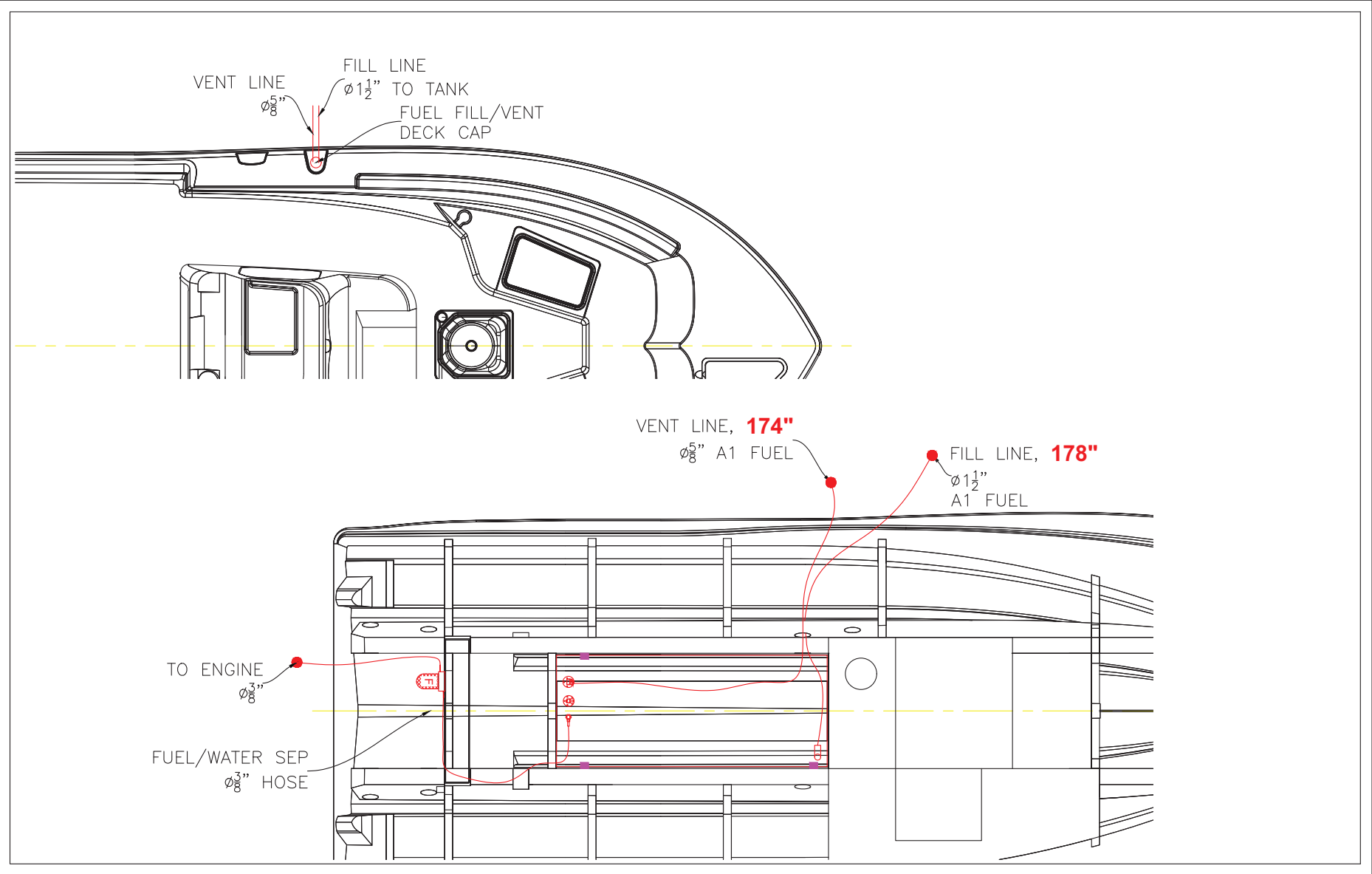

LIVEWELL SYSTEM

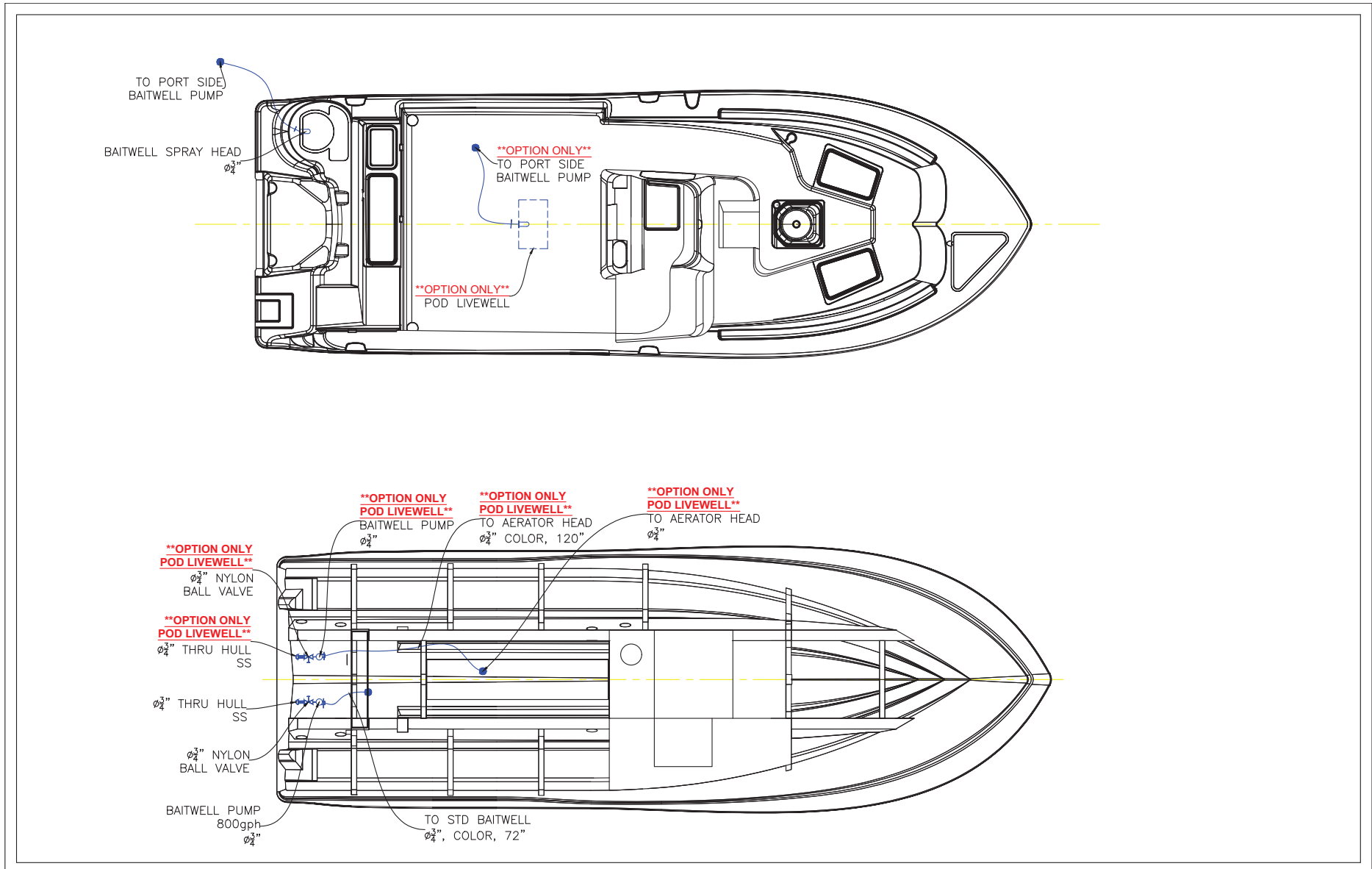

MISTER SYSTEM

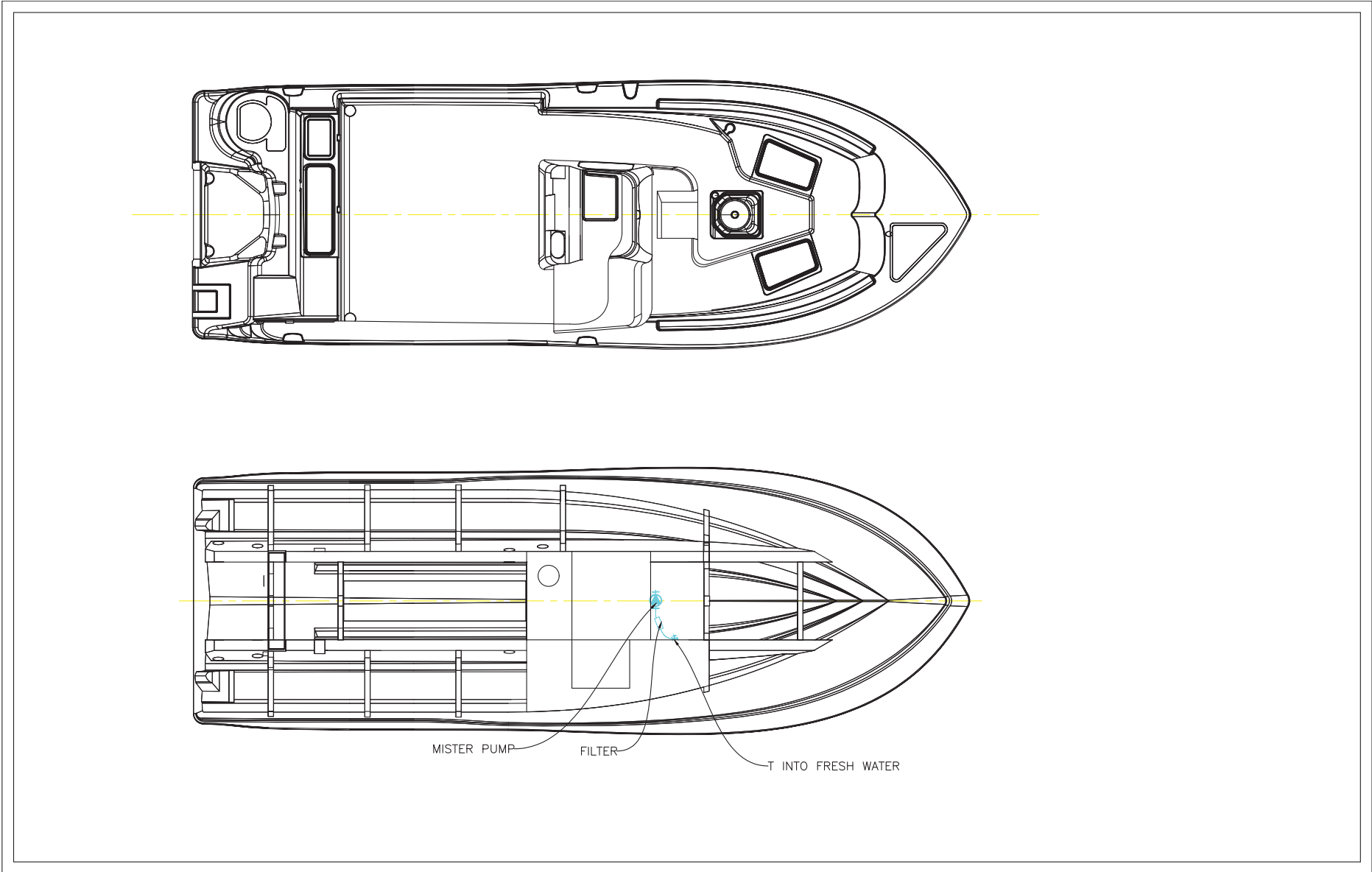

RAW WATER SYSTEM

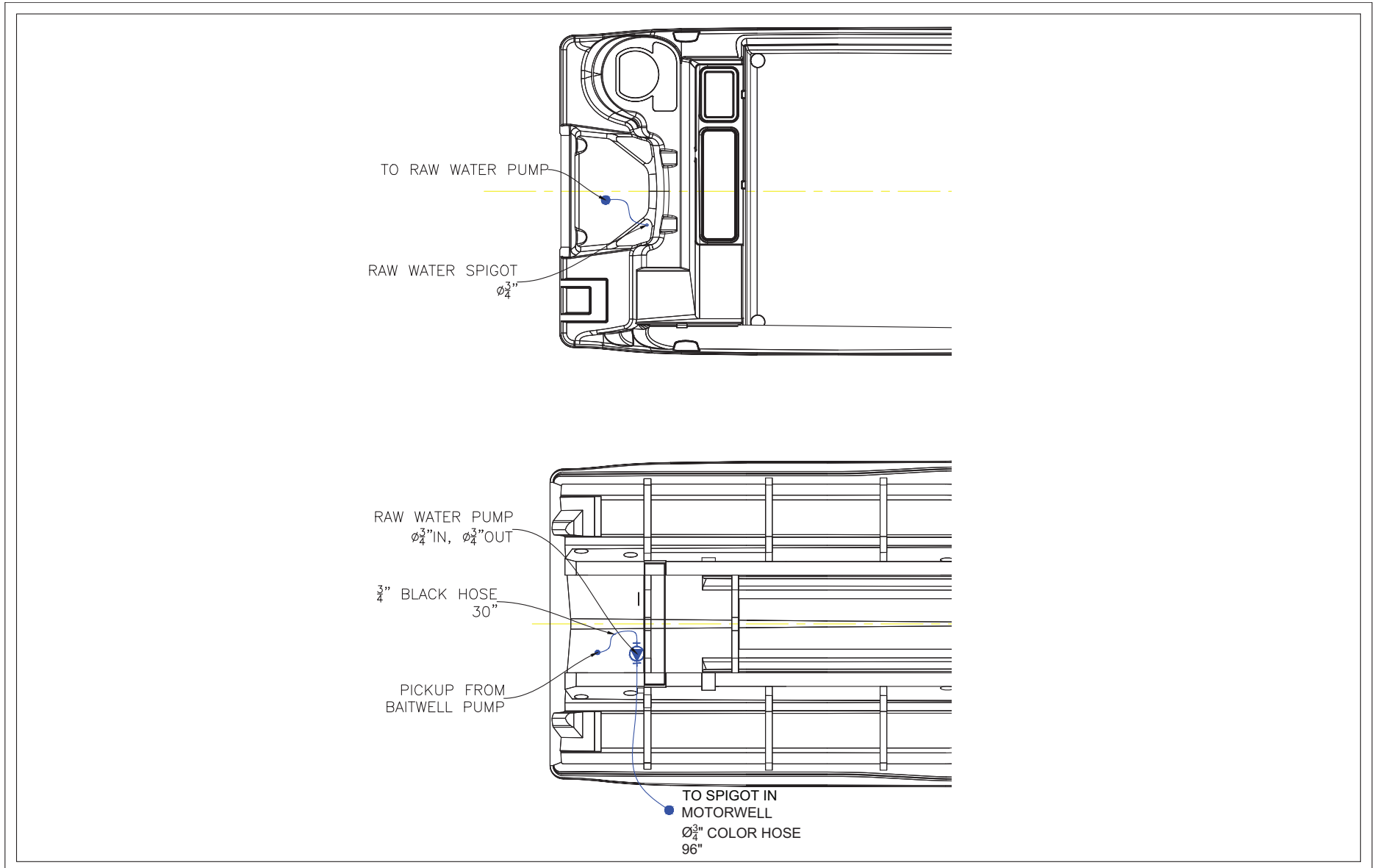

WASTE SYSTEM

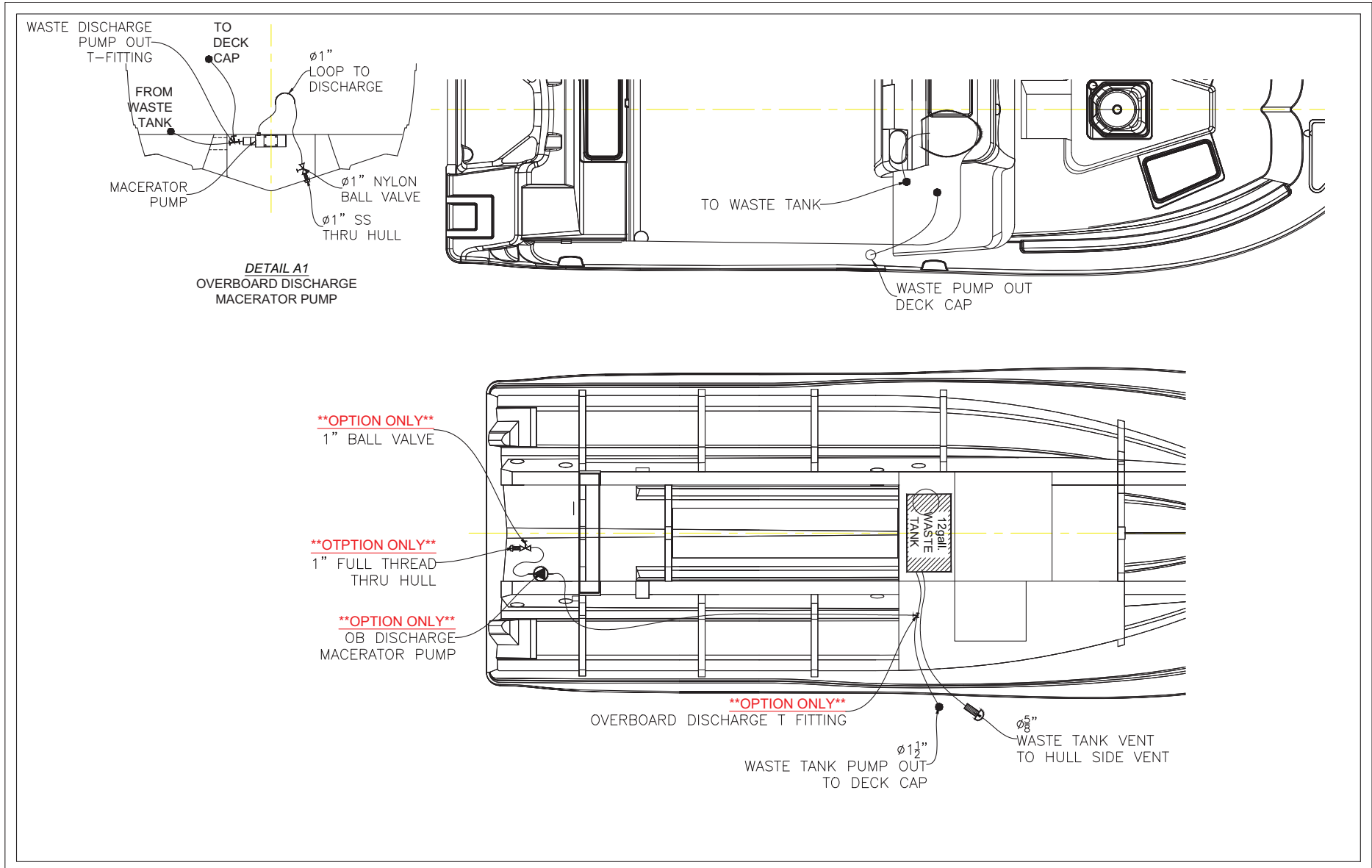

BILGE SYSTEM

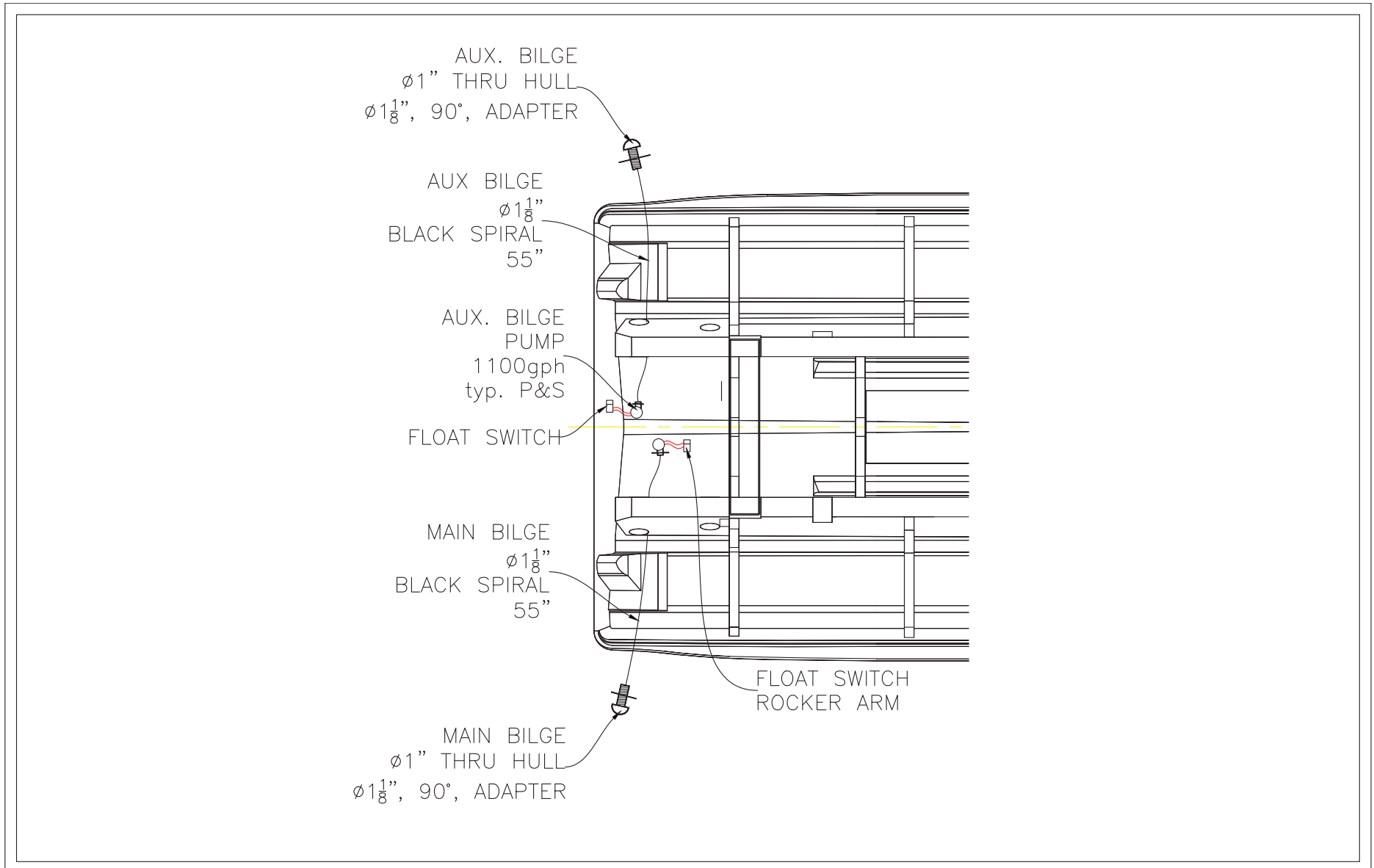

DRAINS

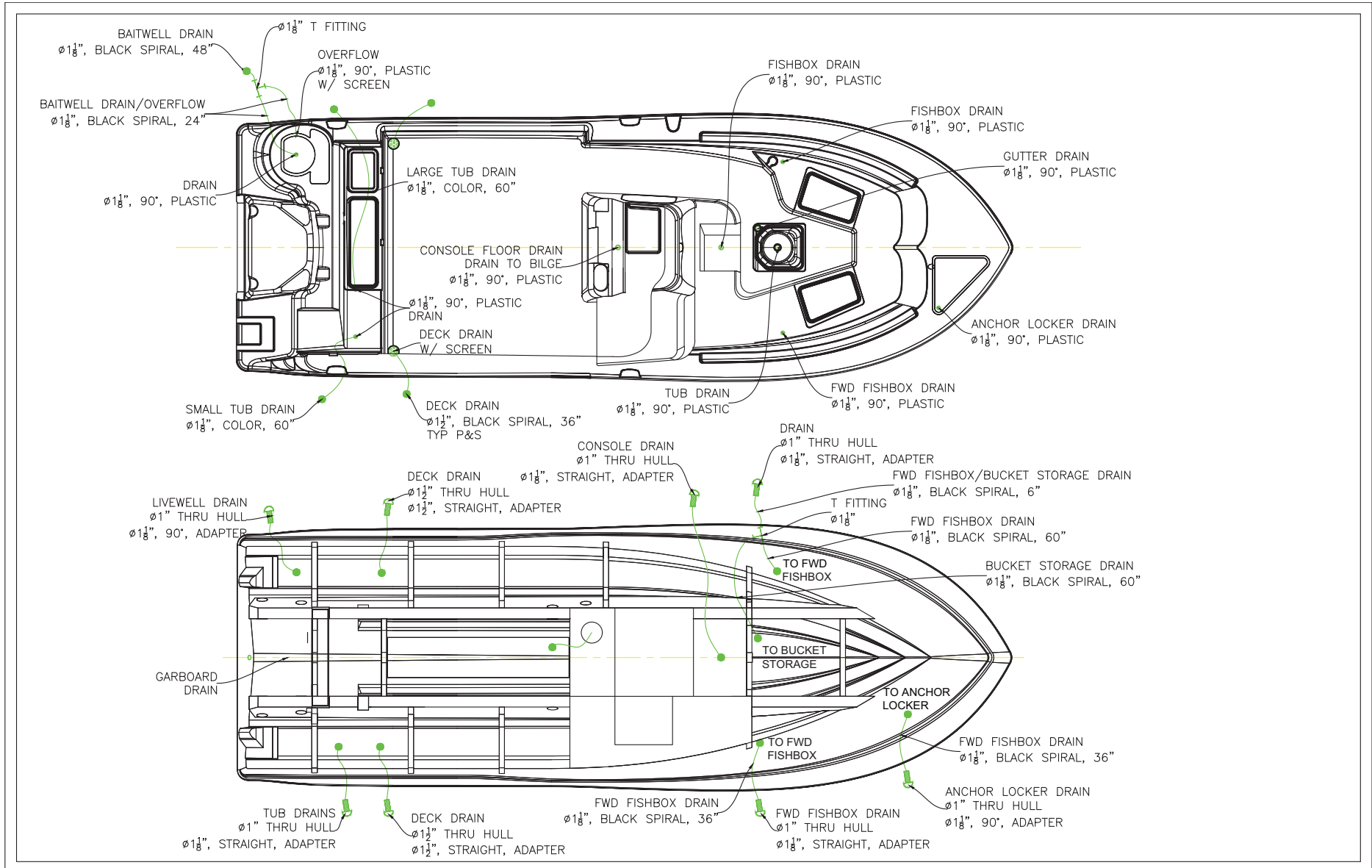

ELECTRICAL SCHEMATICS

TYPICAL 2-BATTERY SETUP WITH TRANSOM

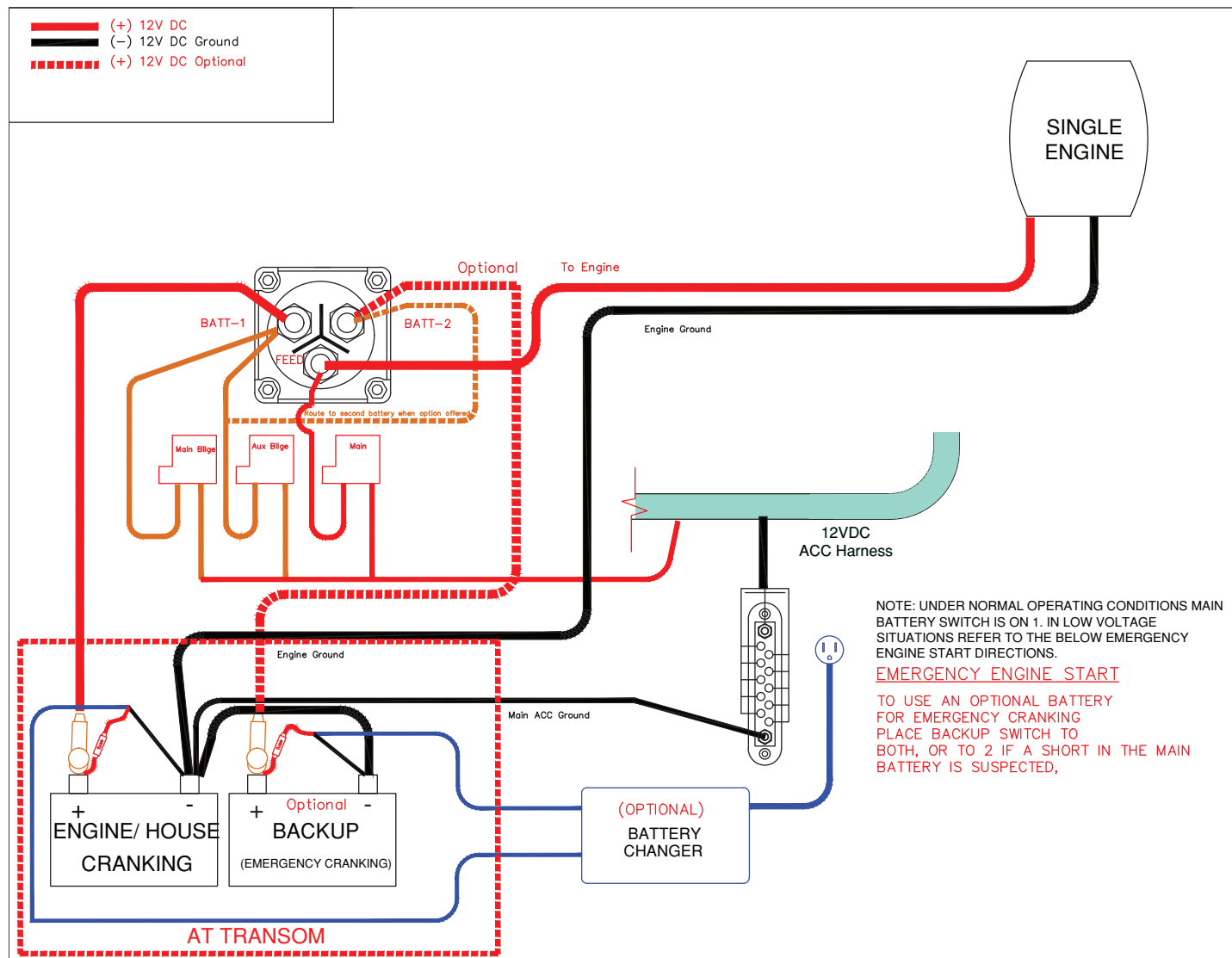

PANEL SWITCH DEUTSCH (P/N 6114)

Start Use MY2016

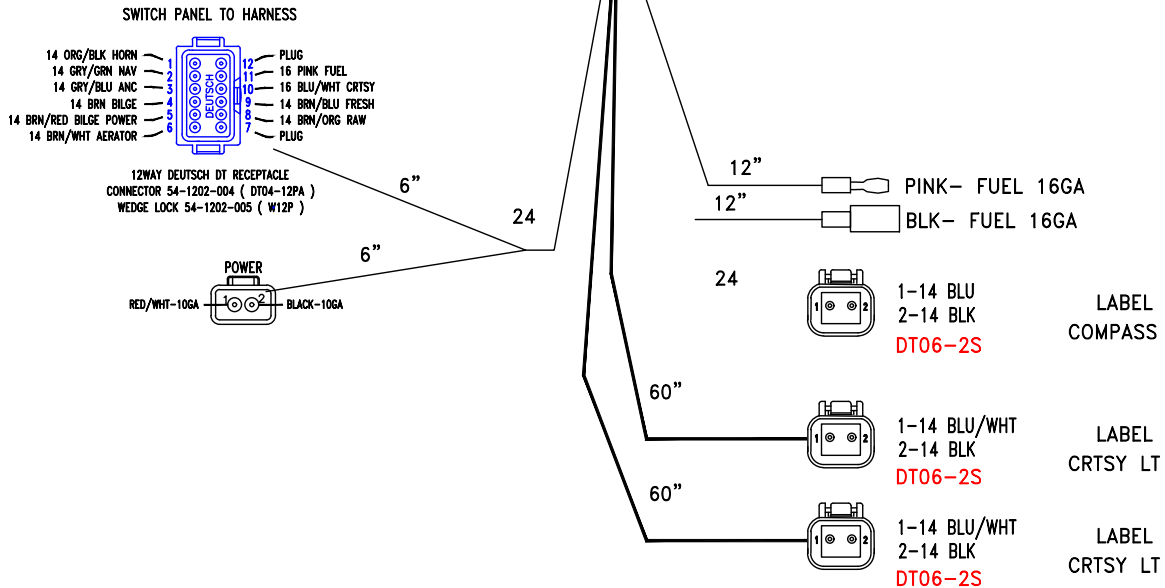
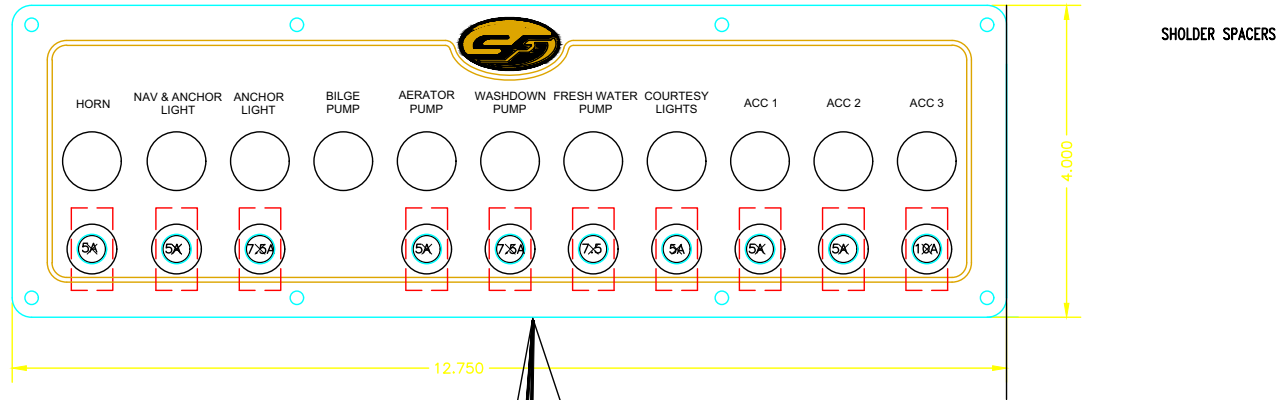

PANEL
186-206-249

ACC1- MOOD LIGHT
ACC2- UNDERWATER LT
ACC3- SPREADER LIGHT

SFX-249-80 (SEAFOX PT# 6114)

HARNES LINER W/ KICKER/INFIN (P/N 6400)

249 Avenger Cabin/nav/ speaker

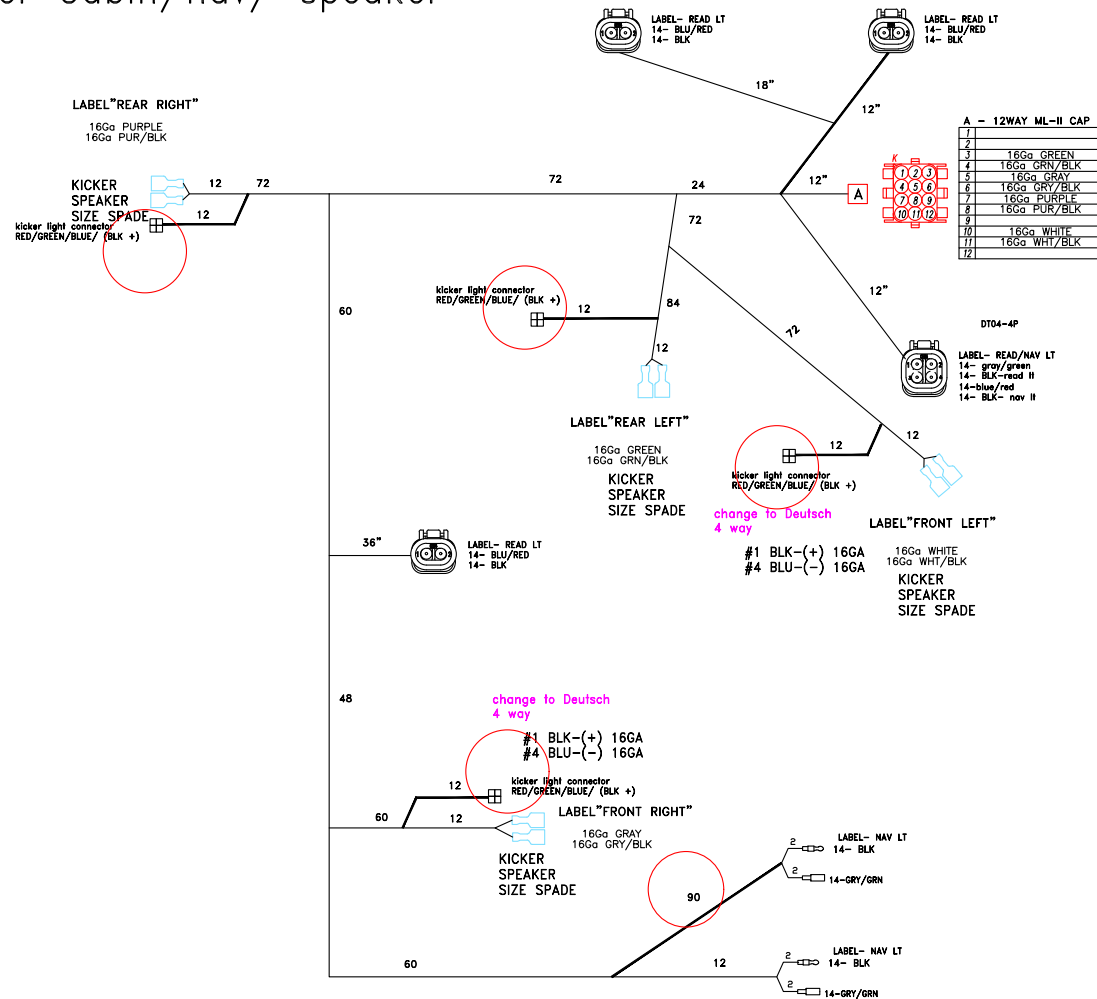

sf# 6400, upm# sfx-676-10B

Avenger Cabin- Nav w/ kicker Harness

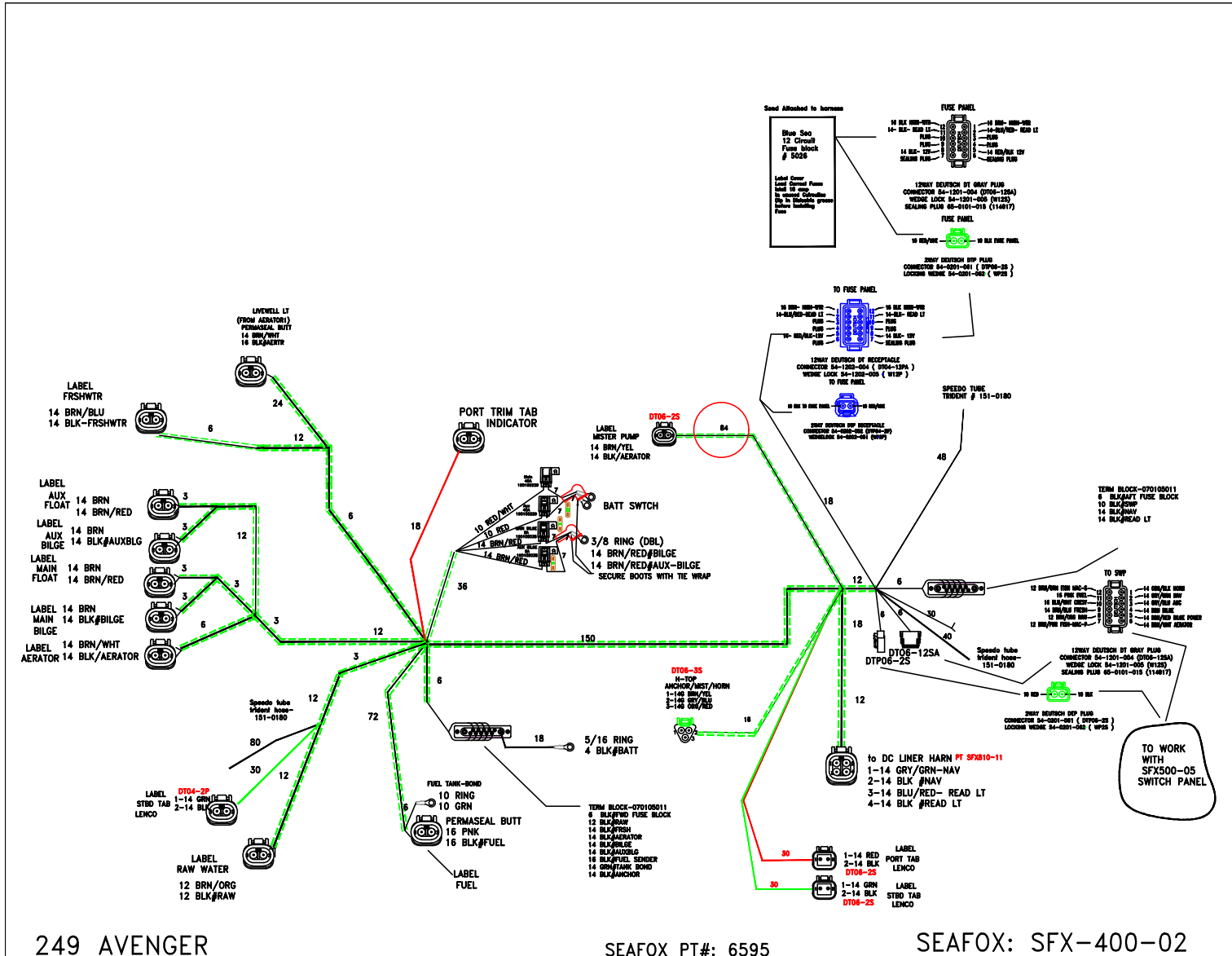

TRIMTABS ELECTRIC SWITCH STANDARD (P/N 2895) – OPTIONAL

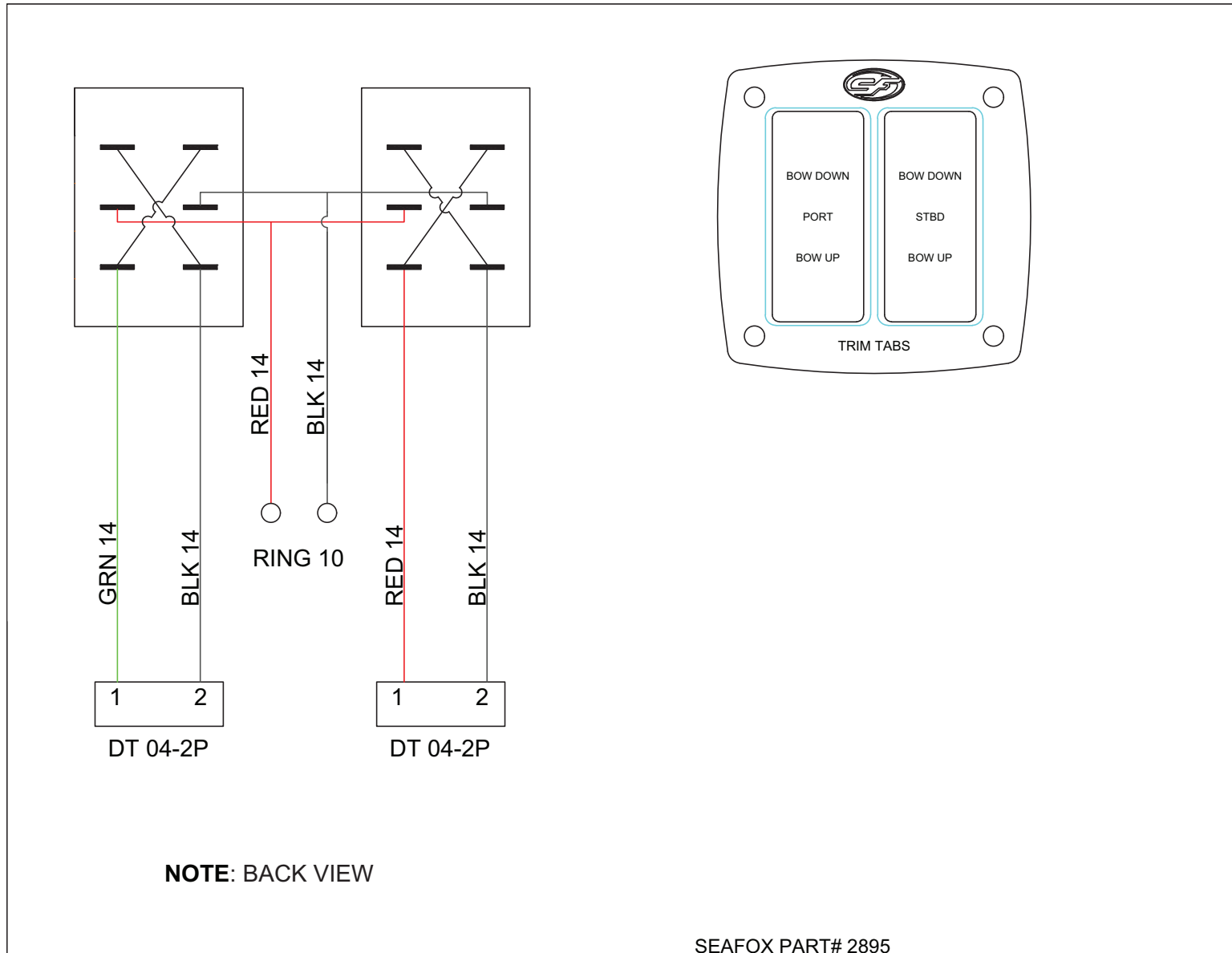

HARNESS MOOD LT W/ DEUTSCH (P/N 6128) – OPTIONAL

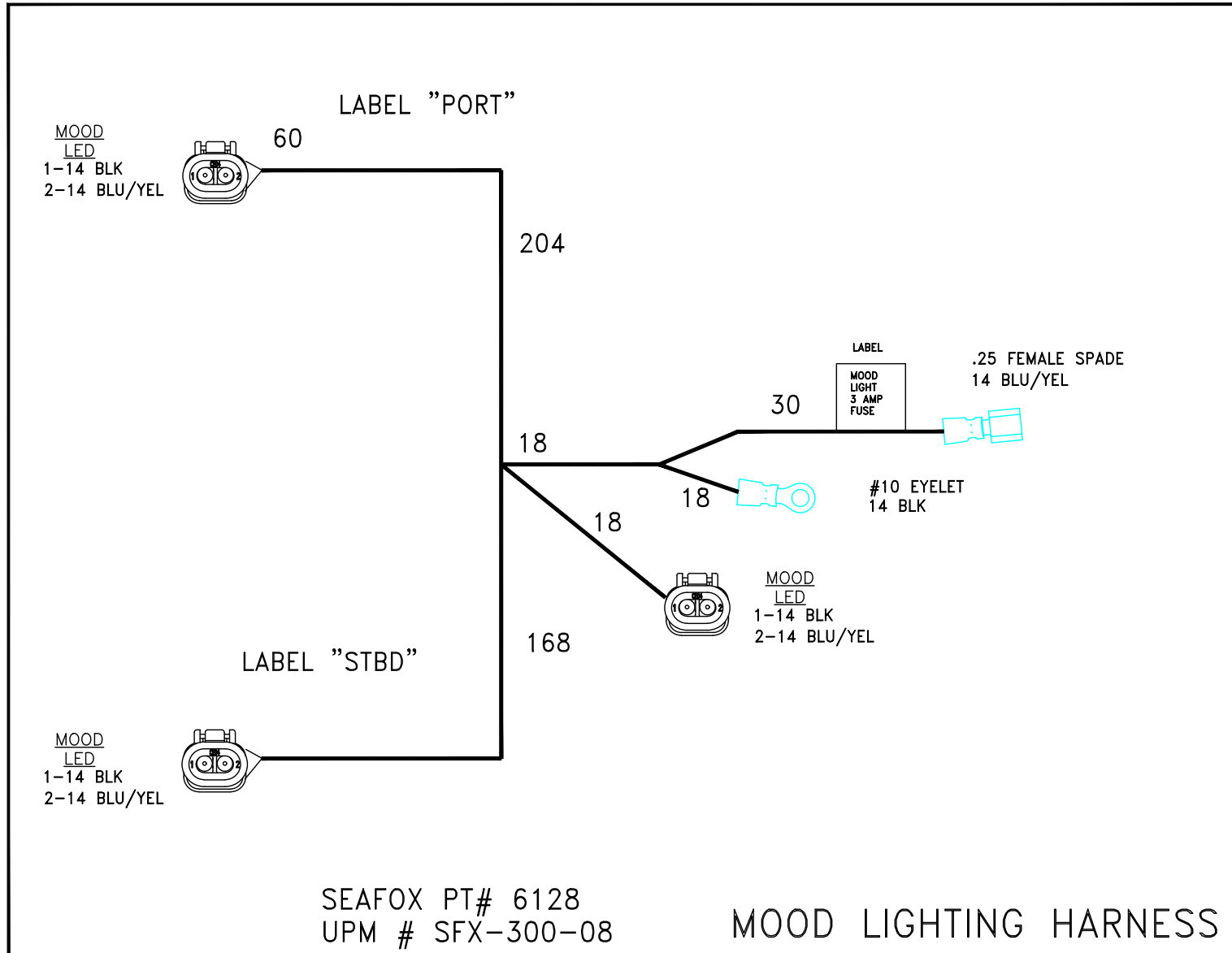

HARNES STEREO INFINITY CON (P/N 6129) – OPTIONAL

CUSTOMER SEAFOX BOAT CO. W/O # _____

PART # 6129 UPM# SFX-300-09 DUE DATE _____

MODEL ALL MODELS

FILENAME _____ DESCRIPTION HARNES STEREO INFINITY/JENSEN

NOTES:

- (1) SPLICE CONNECTION IS SOLDER DIPPED AND INSULATED WITH ADHESIVE-LINED HEAT-SHRINK
- (2) TERMINAL LEGEND:
- = ADHESIVE-LINED CRIMP CONNECTOR
 - = NON-INS 1/4" FEM. QUICK CONNECTOR W/ DBL-WALL SHRINK
 - = NON-INS 0.205" FEM. QUICK CONNECTOR W/ DBL-WALL SHRINK
 - = #8 SNAP SPADE W/ DBL-WALL SHRINK
 - = 0.156 NON-INS MALE W/ BLUE INSULATOR
 - = 0.156 NON-INS FEMALE W/ BLUE INSULATOR
 - = RING TERMINAL W/ ADHESIVE-LINED SHRINK OR SOLDER DIPPED AND ADHESIVE-LINED SHRUNK
- (3) " " = TAGGING TEXT

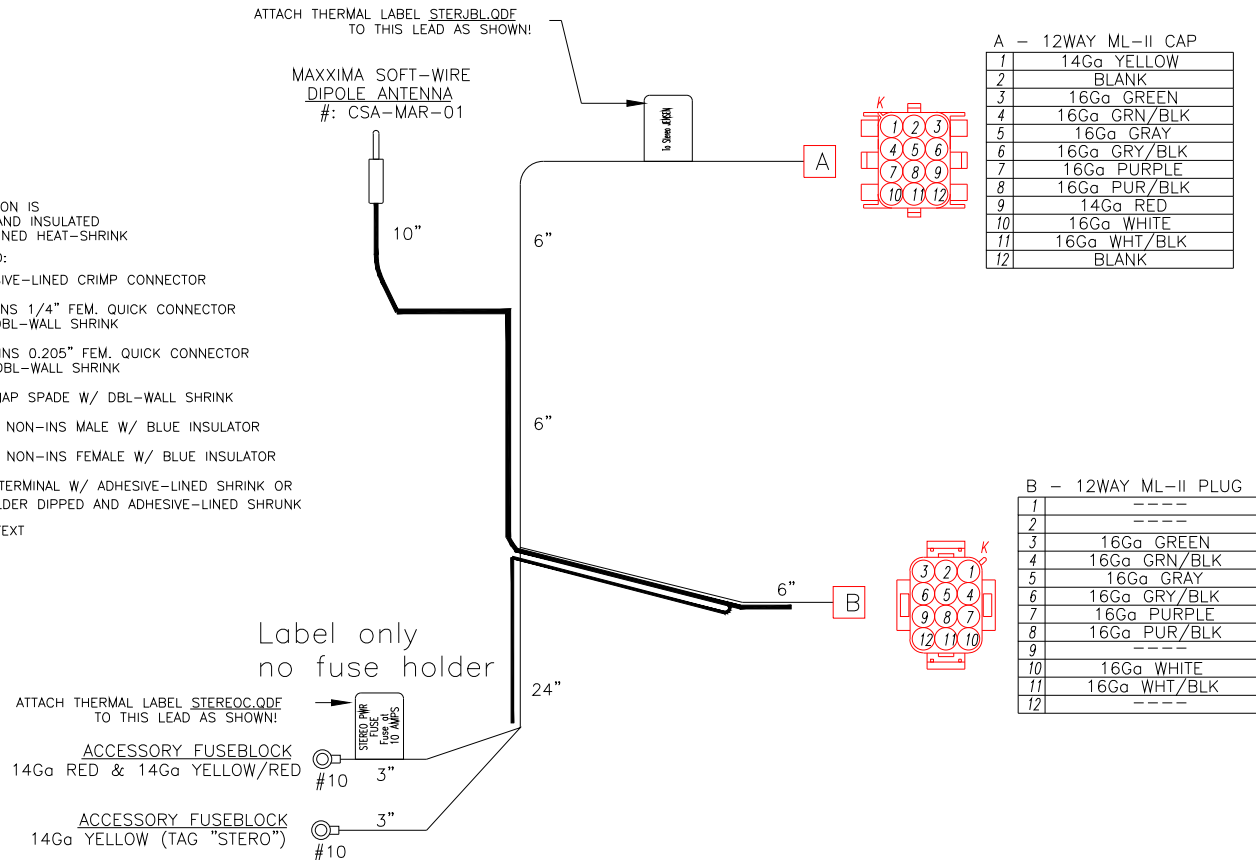

HARNES UNDERWATER LT W/ DEUTSCH (P/N 6133) – OPTIONAL

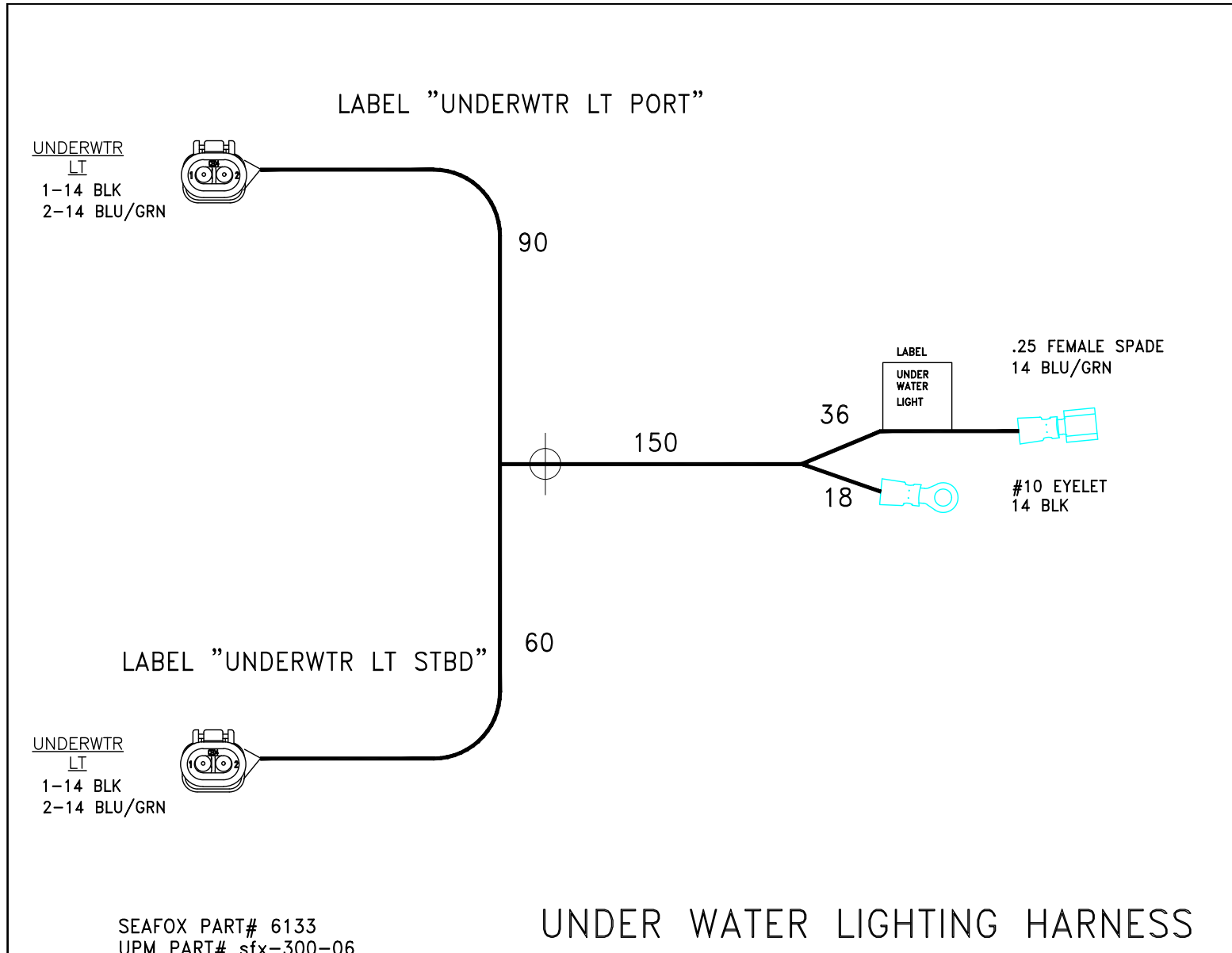

HARNESS WINDLASS HULL AFT BATTERY (P/N 6134) – OPTIONAL

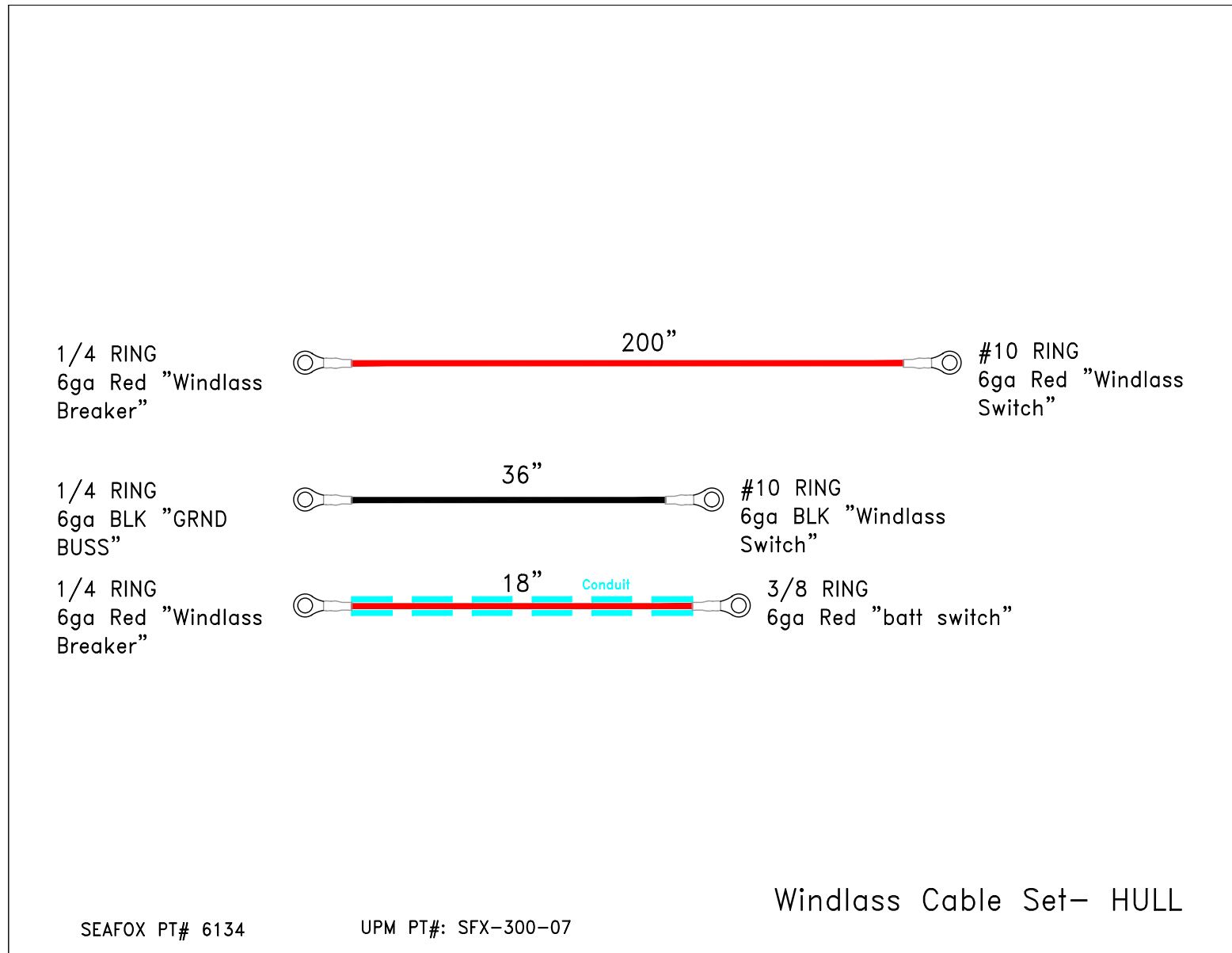

HARNESS WINDLASS DECK OPTION (P/N 6135) – OPTIONAL

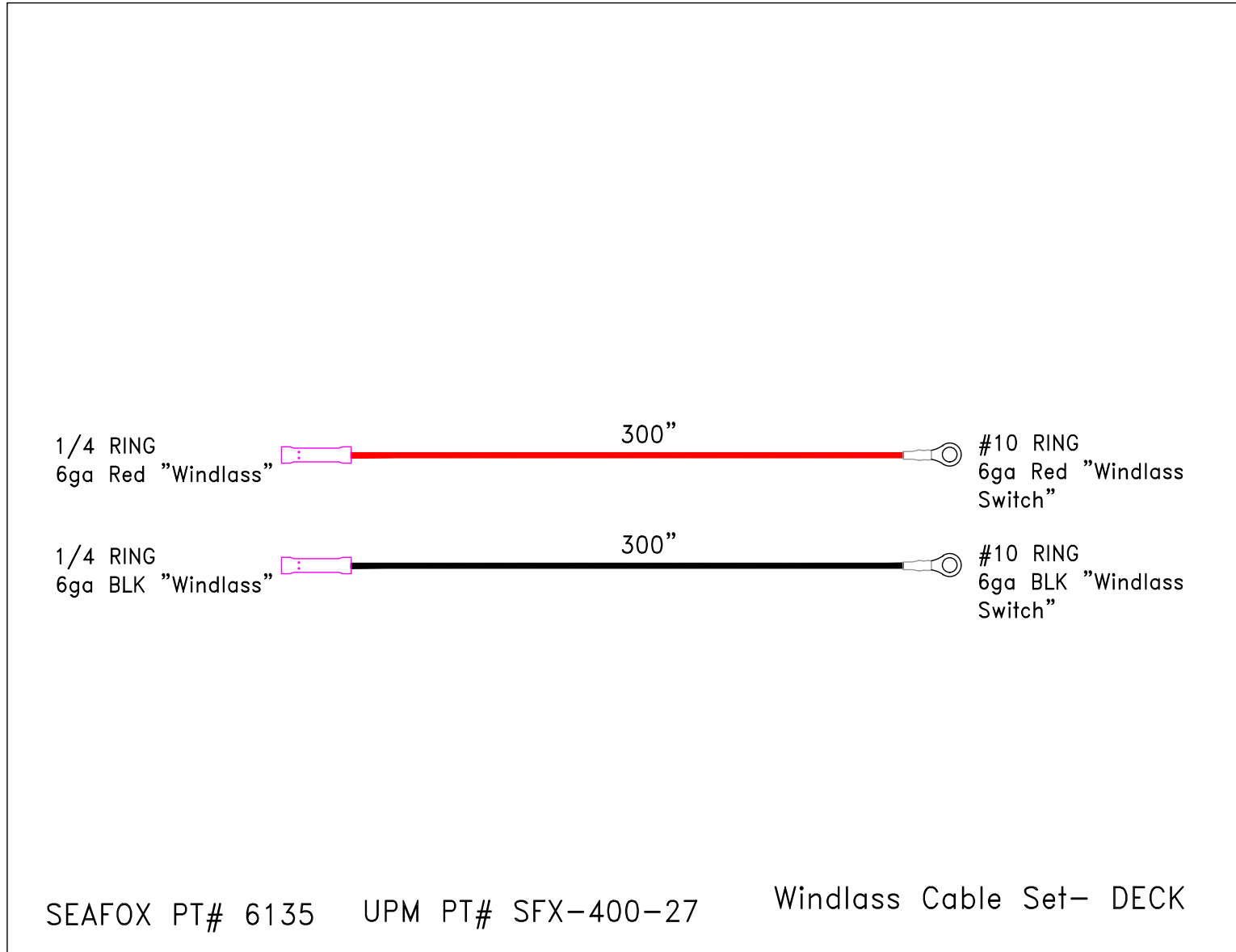

ELECTRIC FLUSH-DISCHARGE SWITCH PANEL (P/N 6136) – OPTIONAL

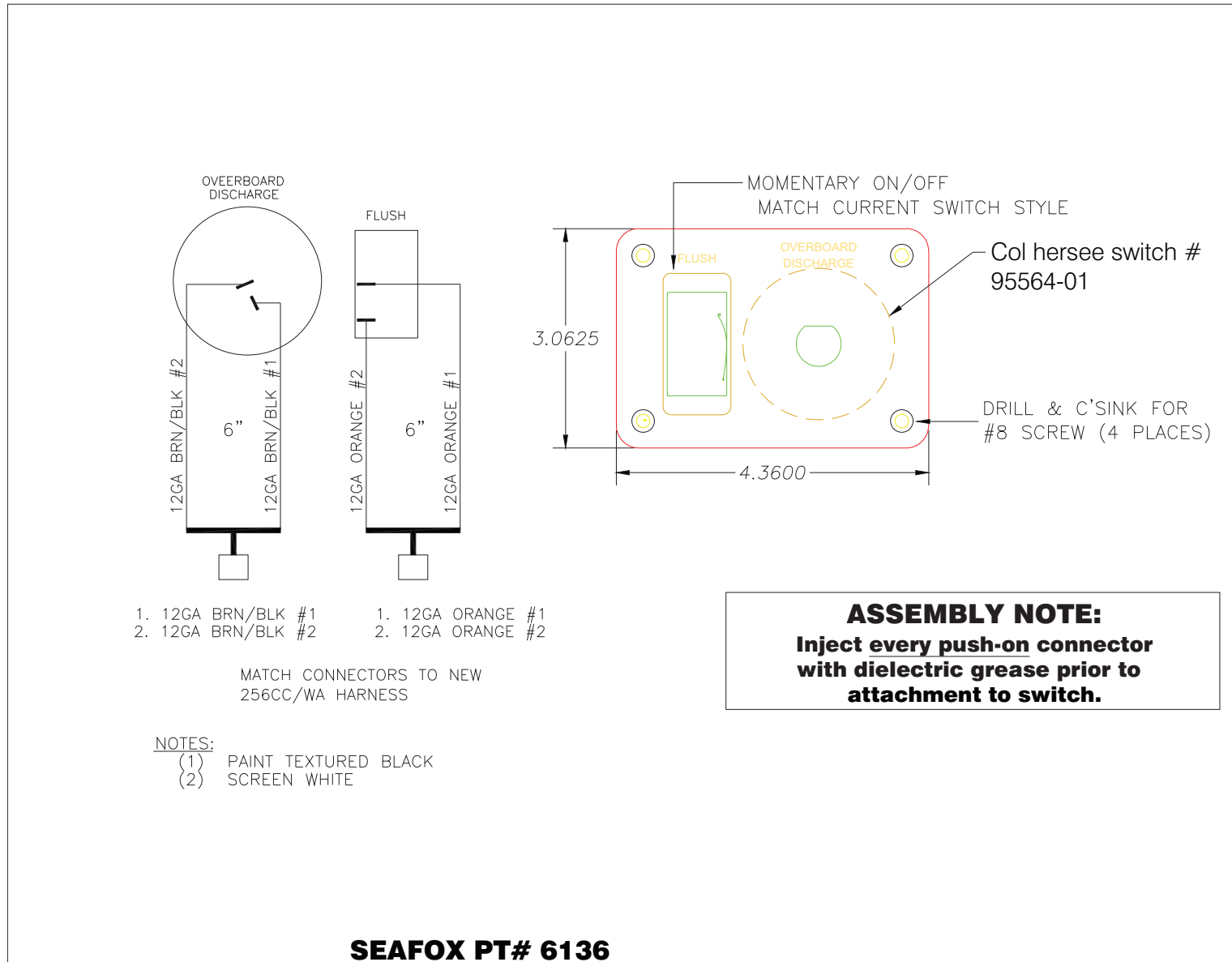

U PANEL SWITCH ULTIMA (P/N 6463) – OPTIONAL

SEAFOX PT# 6463
UPM PT# SFX-600-40

3 OF 3

"J"-FROM SWITCH PANEL

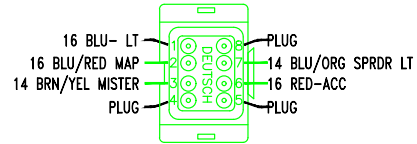

8WAY DEUTSCH DT RECEPTACLE
CONNECTOR 54-0802-008 (DT04-8PA)
WEDGE LOCK 54-0801-009 (W8P)

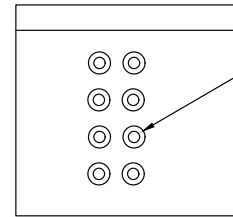

SHIP WITH SWP ASSEMBLY:
081401002 (8) SHOULDER WASHER
IN 4 X 4 PLASTIC BAG

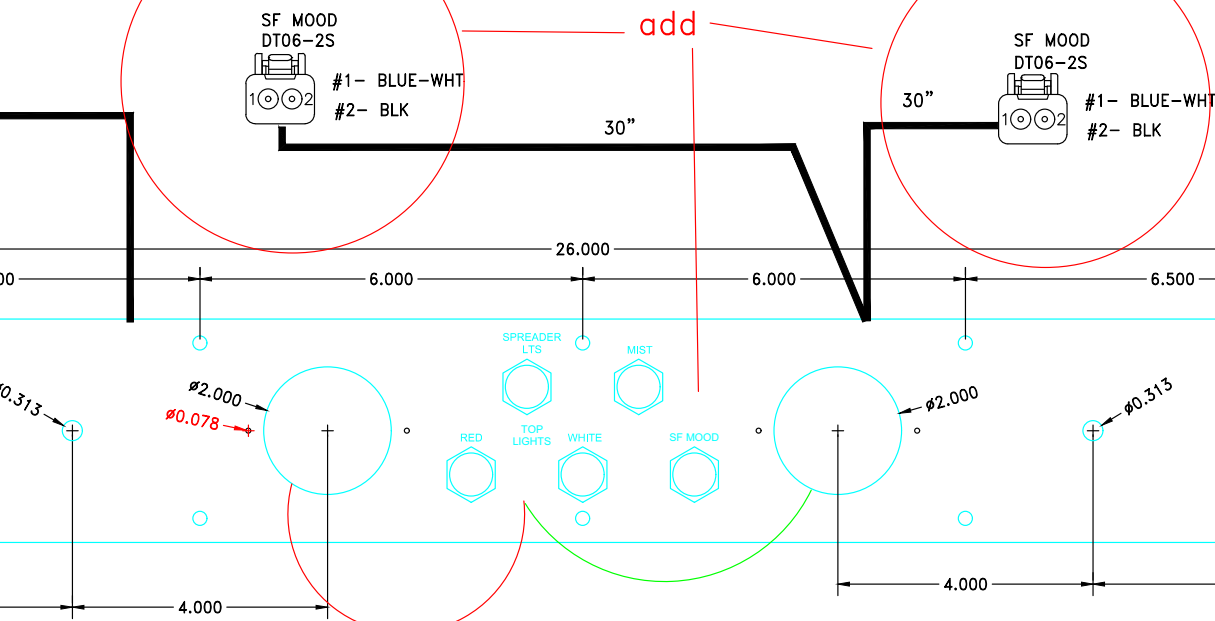

CENTER CONSOLE ULTIMA TOP – 2016 (P/N 6463, 6464 AND 6476) – OPTIONAL

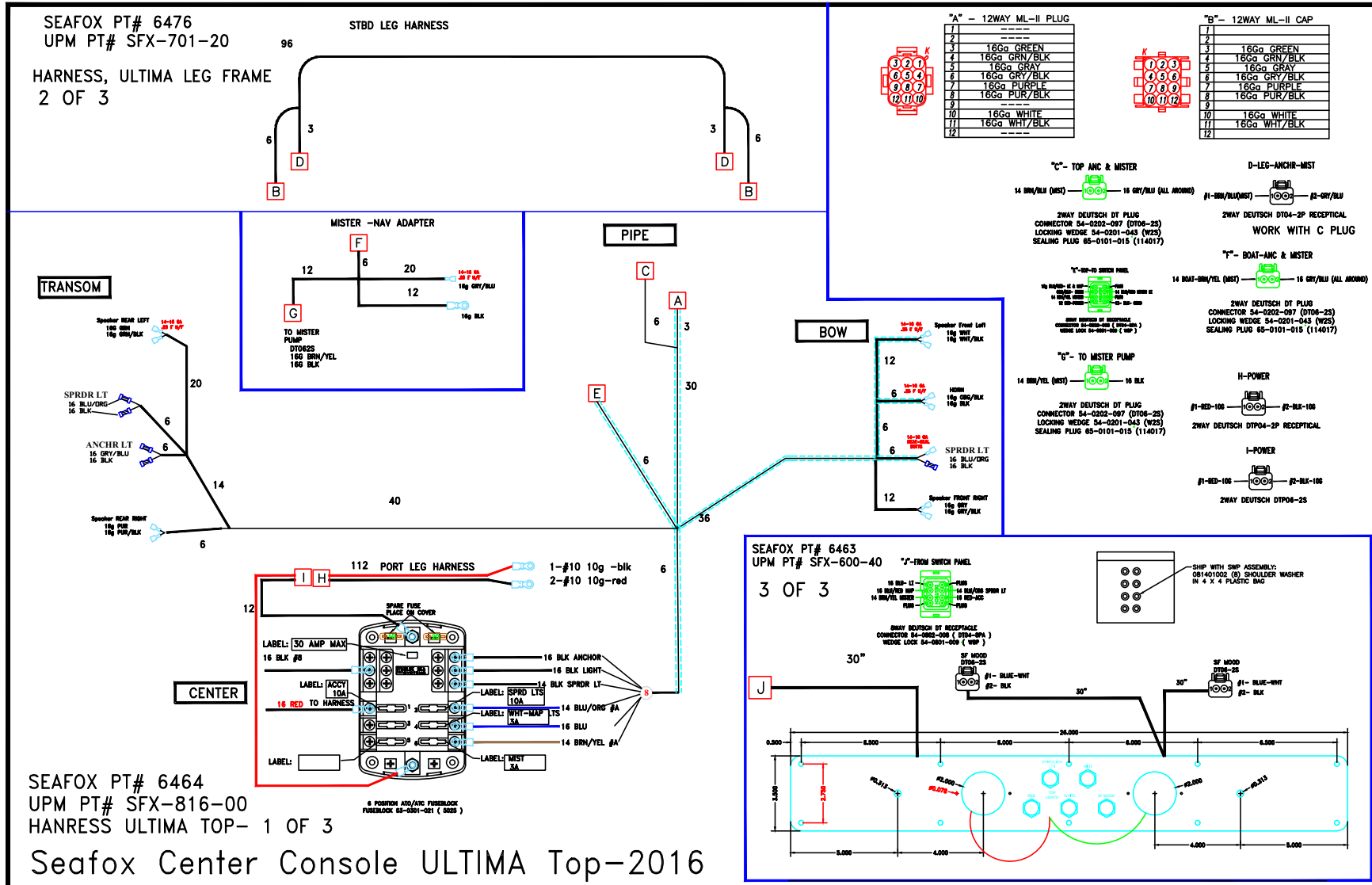

ELECTRIC FLUSH SWITCH PANEL (P/N 6870) – OPTIONAL

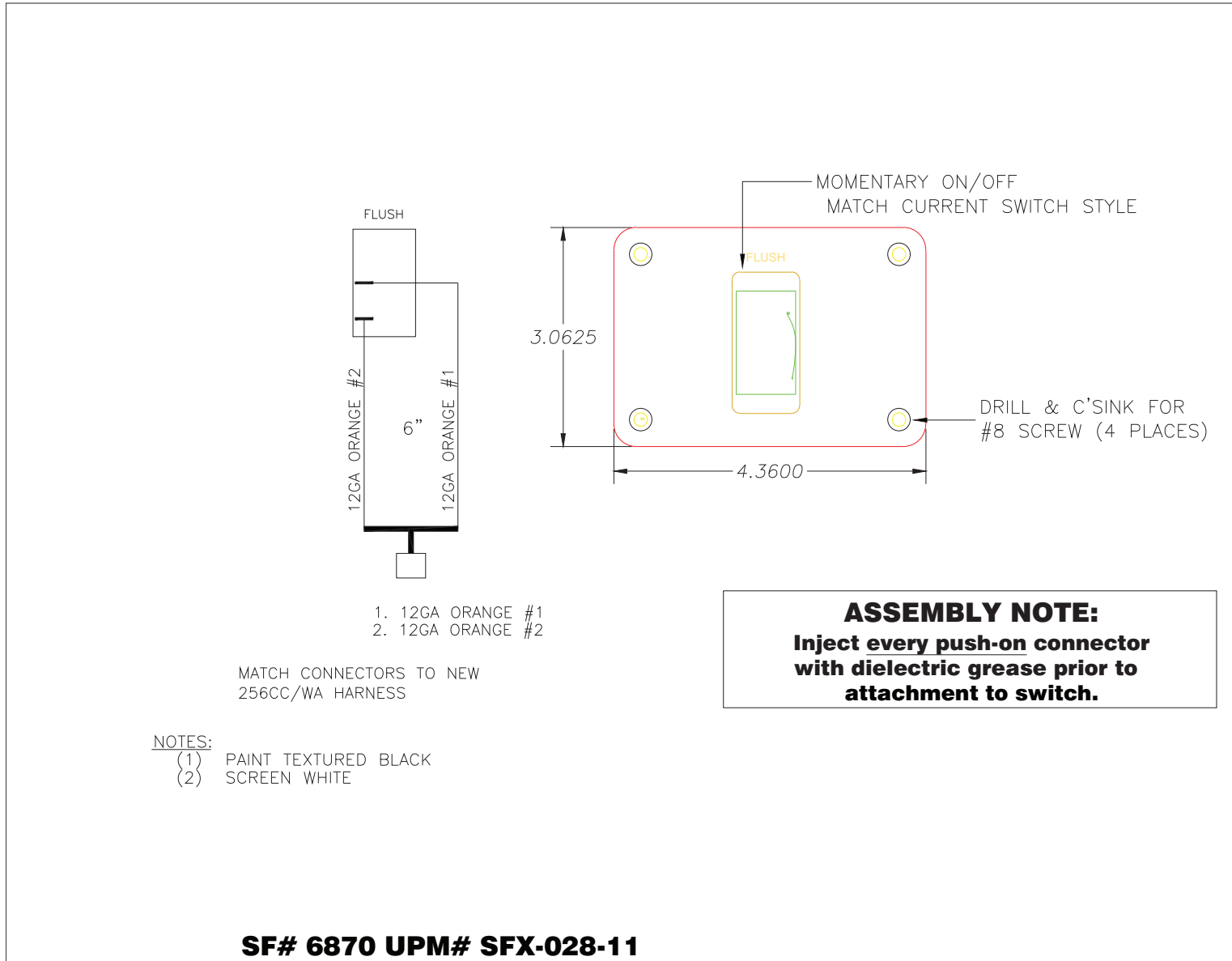

HEAD HARNESS ORB 249AV (P/N 6871) – OPTIONAL

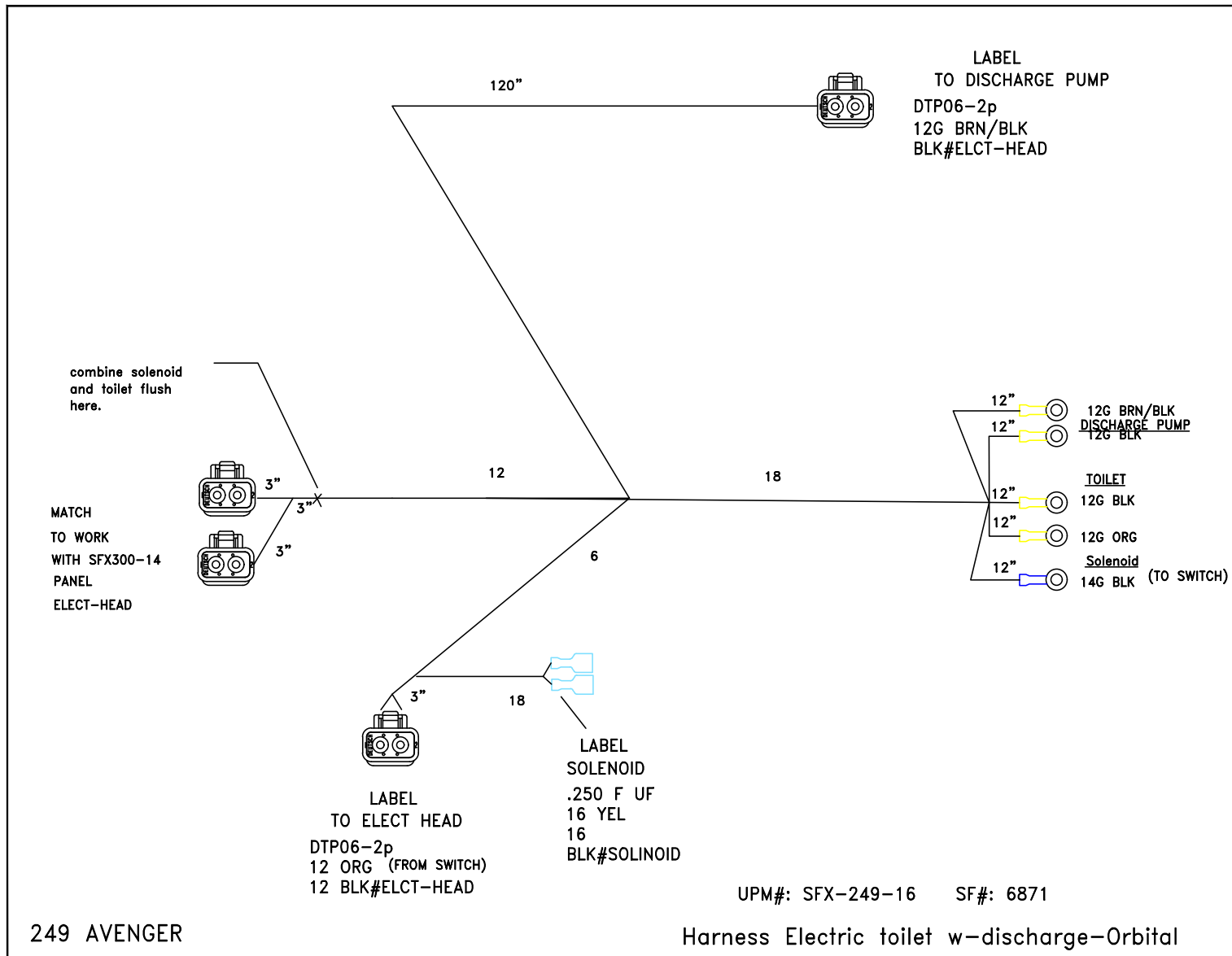

This Page Intentionally Left Blank

SEA FOX

BOAT WORKS

Sea Fox Boat Company, Inc.
2550 Highway 52
Moncks Corner, SC 29461-5024

Telephone: 843-761-6090
www.seafoxboats.com

Ken Cook Co.
Printed in U.S.A.
Rev 0124