

251B



Owner's Manual Supplement

www.seafoxboats.com

SEA FOX BOAT'S DISCLAIMER

The following Owner's Manual is provided for information and educational purposes only and is not intended to offer or provide legal advice or create a contractual relationship between Sea Fox Boat Company and the owner of any Sea Fox brand vessel. Please beware that as a vessel owner you have non-delegable responsibilities regarding the safety, maintenance, fitness, and operation of your vessel and the extent of such responsibilities is ultimately determined by Federal law and regulations, the general maritime law of the United States, the laws and regulations of the states and territories of the United States, or the laws and regulations of the country where you operate your vessel. To fully understand your responsibilities as a vessel owner, and before operating or letting any third-party operate your vessel, we recommend that you consult the services of a qualified lawyer in admiralty and maritime law.

TABLE OF CONTENTS

Introduction	3	Harness ACC w/Deutsch (P/N 6402)	18
Specifications	3	Panel Switch Shroud (P/N 6510)	19
Designated Occupant Seating	4	Harness Nav Short	20
Safety Decals	5	Trimtabs Electrical Switch Standard (P/N 2895) – Optional	21
Plumbing Schematics	7	Harness Mood Light w/Deutsch (P/N 6128) – Optional	22
Bilge System	7	Harness Stereo Infinity Con (P/N 6129) – Optional	23
Drains	8	Harness Stereo Infinity Deck (P/N 6130) – Optional	24
Drains (continued)	9	Harness Underwater Light w/Deutsch (P/N 6133) – Optional ..	25
Fresh Water System	10	U Panel Switch Ultima (P/N 6463) – Optional	26
Fuel System	11	Center Console Ultima Top – 2016 (P/N 6463, 6464 and 6476) –	
Standard Livewell System	12	Optional	27
Mister System	13	Harness Trimtab Electric 20 ft Lenco (P/N 6564) – Optional	28
Pod Livewell System	14	Harness Stereo Kicker Con 2016 (P/N 6851) – Optional	29
Raw Water System	15	Harness Stereo Kicker Deck 2016 (P/N 6852) – Optional	30
Electrical Schematics	16	Panel Switch Shroud (P/N 6858) – Optional	31
Typical 2-Battery Setup in Console	16		
Harness Trolling Motor 180-240 (P/N 4823)	17		

This Page Intentionally Left Blank

INTRODUCTION

Congratulations and Welcome Aboard! With so many boat brands to choose from, we want to congratulate you on your decision to choose Sea Fox Boats. For more than 28 years, Sea Fox offers the finest hand-crafted saltwater boats carefully balanced with the build-quality, features, styling and performance for the fairest price. Our passion for boating is evident in every model we make and we appreciate that you've noticed the Sea Fox difference.

We share your love for the moments spent on the water with friends and family, which is why every Sea Fox boat offers a unique blend of fishing/family options, technologies and innovative features. Your choice of a Sea Fox affirms that you have performed your research and compared the value of your model with the competition.

Whether you are new to the boating lifestyle or an old salt, we ask that **you and all other operators** read the owner's manual, this supplement, and all other literature provided with the boat **before** operating the boat or any equipment. We also recommend that all operators enroll in a boating safety course available online - see References and Contact Information in this section for education resources online.

This supplement contains model-specific information not included with the owner's manual. This manual is not intended to be a replacement for specific product literature provided by engine, accessory or other major equipment manufacturers, but rather to supplement that information.

Because of our philosophy of continuous product improvement, this manual serves as a general guide only, so the specifications and illustrations used may not match the equipment on your boat and are intended only as general reference views.

We welcome you to the Sea Fox family and wish you many years of boating enjoyment!

SPECIFICATIONS

Max. Weight Capacity	2200 lbs (1000 kg)
Persons	8
Persons Weight	1200 lbs (544 kg)
Max. HP	300 hp (224 kw)
L.O.A.	24' 4" (7.41 m)
Beam	8' 6" (2.59 m)
Draft	13 in. (0.33 m)
Height, Keel to Top (Light Folded)	106 in. (2.69 m)
Bridge Clearance Hard Top	93 in. (2.36 m)
Max. Weight Boat (w/ Fluids, Largest HP)	4645 lbs (2107 kg)
Fuel Tank Capacity	77 gal (291 L)
Freshwater Tank Capacity	6 gal (23 L)
Holding Tank Capacity	N/A

DESIGNATED OCCUPANT SEATING

Be sure all passengers are properly seated in designated seating positions and not riding on the bow, bow pulpit, deck, gunwale or rear sun deck while underway. Passengers must use hand-holds and use caution when riding in the bow. Move to the aft passenger seats during rough water operation or if visibility is restricted.

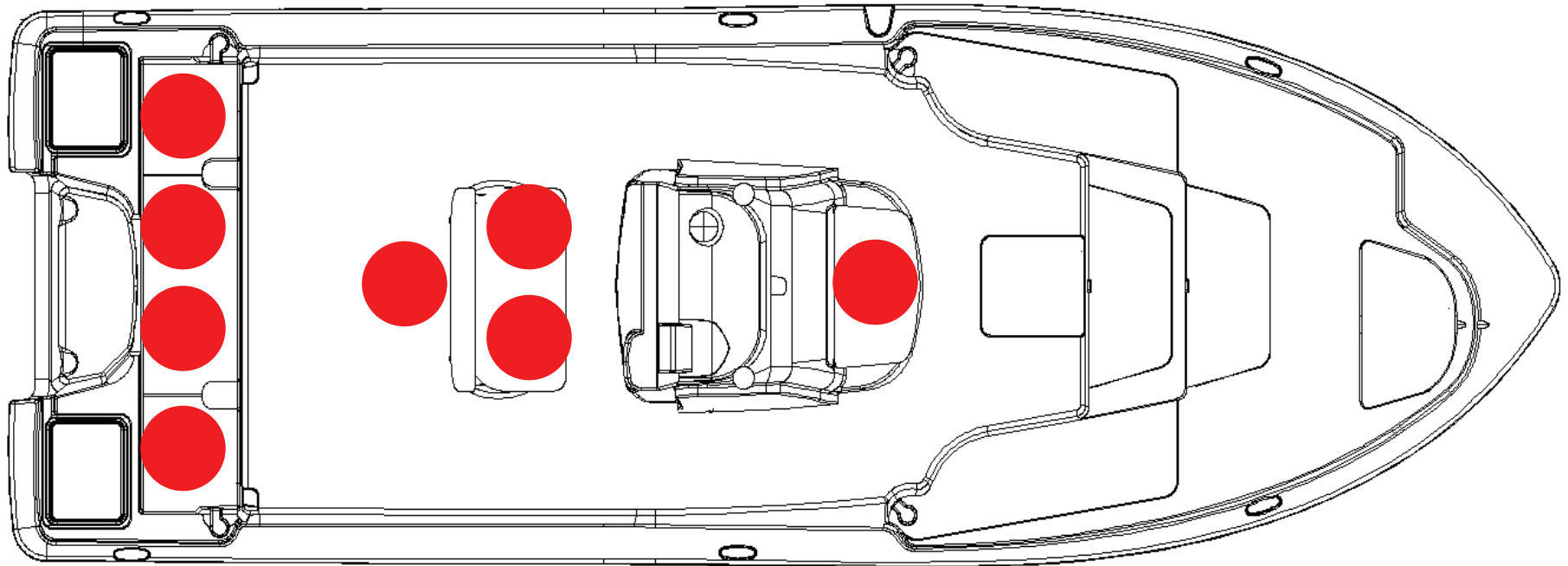

● = Seat position

SFOX-0015

SAFETY DECALS

4 **BATTERY CHARGER**
U36438-01

4 **WARNING**
Operating, servicing and maintaining a recreational marine vessel can expose you to chemicals including engine exhaust, carbon monoxide, phthalates, and lead, which are known to the State of California to cause cancer and birth defects or other reproductive harm. To minimize exposure, avoid breathing exhaust, service your vessel in a well-ventilated area and wear gloves or wash your hands frequently when servicing this vessel. For more information go to www.P66warnings.ca.gov/marine. U36438-01

6 **DANGER**
ROTATING PROPELLER CAN CAUSE SERIOUS INJURY OR DEATH. SHUT OFF MOTOR WHEN NEAR PERSONS IN WATER. U36070-01

6 **DANGER**
ROTATING PROPELLER CAN CAUSE SERIOUS INJURY OR DEATH. SHUT OFF MOTOR WHEN NEAR PERSONS IN WATER. U36070-01

1 **WARNING**
Failure to follow these warnings could cause SERIOUS INJURY OR DEATH.
• REMAIN PROPERLY SEATED AND HOLD ON to available handrails while boat is moving to avoid falling overboard or being ejected from the boat. Do not sit on seat backs, gunwales or outermost deck edges.
• WEAR U.S. COAST GUARD APPROVED LIFE JACKETS.
• DO NOT OVERLOAD THE BOAT. OCCUPANTS AND GEAR MUST BE PROPERLY AND EVENLY DISTRIBUTED fore and aft, and on both sides of the boat. Improper loading and/or overloading may result in poor handling, sudden loss of control, swamping and/or capsizing.
• REFER TO AND OBEY THE DESIGNATED OCCUPANT SEATING POSITIONS that are indicated by the manufacturer for your specific model.
• OBEY THE OPERATOR at all times.
• DO NOT RESTRICT THE OPERATOR'S VISION.
• DO NOT DEPART THE VESSEL without informing the operator.

5 **WARNING**
Failure to follow these warnings could cause SERIOUS INJURY OR DEATH.
• REMAIN PROPERLY SEATED AND HOLD ON to available handrails while boat is moving to avoid falling overboard or being ejected from the boat. Do not sit on seat backs, gunwales or outermost deck edges.
• WEAR U.S. COAST GUARD APPROVED LIFE JACKETS.
• DO NOT OVERLOAD THE BOAT. OCCUPANTS AND GEAR MUST BE PROPERLY AND EVENLY DISTRIBUTED fore and aft, and on both sides of the boat. Improper loading and/or overloading may result in poor handling, sudden loss of control, swamping and/or capsizing.
• REFER TO AND OBEY THE DESIGNATED OCCUPANT SEATING POSITIONS that are indicated by the manufacturer for your specific model.
• OBEY THE OPERATOR at all times.
• DO NOT RESTRICT THE OPERATOR'S VISION.
• DO NOT DEPART THE VESSEL without informing the operator.

Manufactured by
SEA FOX
BOAT WORKS

6 **AMERICAN BOAT & YACHT COUNCIL**
ABYC
Boating Safety... Built In
www.abyc.org
MEMBER

6 **PROTECTED DESIGN**
SEA FOX
BOAT WORKS
U.S. LIBRARY OF CONGRESS

6 **NO WOOD! NO ROT!**
U36060-01

6 **RAW WATER**
U36070-01

6 **FRESH WATER**
U36070-01

6 **NON POTABLE WATER**
U36070-01

6 **NON POTABLE WATER**
U36070-01

5 **WARNING**
Moving parts can crush and cut. Keep hands clear while operating bracket. U36070-01

6 **WARNING**
Moving parts can crush and cut. Keep hands clear while operating bracket. U36070-01

6 **WARNING**
Moving parts can crush and cut. Keep hands clear while operating bracket. U36070-01

6 **DANGER**
Carbon monoxide (CO) can cause brain damage or death. Engine and generator exhaust contains odorless and colorless carbon monoxide gas. Carbon monoxide will be around the back of the boat when engines or generators are running. Move to fresh air, if you feel nausea, headache, dizziness, or drowsiness. U36069-01

6 **DANGER**
Carbon monoxide (CO) can cause brain damage or death. Engine and generator exhaust contains odorless and colorless carbon monoxide gas. Carbon monoxide will be around the back of the boat when engines or generators are running. Move to fresh air, if you feel nausea, headache, dizziness, or drowsiness. U36069-01

5 **CAUTION**
TO AVOID DAMAGE TO ENGINE, LOWER SEAT BACK REST BEFORE TRIMMING ENGINE IN TRAILERING POSITION. U36070-01

2 **WARNING** GAS / PETROL ONLY
CONTENTS CAN BE UNDER PRESSURE. AVOID SERIOUS INJURY OR DEATH FROM FIRE OR EXPLOSION. OPEN SLOWLY IN WELL VENTILATED AREA. NO SMOKING OR OPEN FLAMES. U36068-01

4 **MAXIMUM CAPACITIES**
8 PERSONS OR 1200 LBS.
2200 LBS. PERSONS, MOTOR, GEAR
300 H.P. MOTOR
THIS BOAT COMPLIES WITH THE U.S. COAST GUARD SAFETY STANDARDS IN EFFECT ON THE DATE OF CERTIFICATION
SEA FOX BOAT COMPANY, INC.
MONCKS CORNER, S.C. KS6A U36068-01

5 **WARNING**
Leaking fuel is a fire and explosion hazard. Avoid serious injury or death from fire or explosion from leaking fuel. Inspect system for leaks at least once a year.

4 **WARNING**
CARBON MONOXIDE (CO) CAN CAUSE BRAIN DAMAGE OR DEATH. Carbon monoxide can be present in the cabin. Signs of carbon monoxide poisoning include nausea, headache, dizziness, drowsiness, and lack of consciousness. MOVE TO FRESH AIR if anyone shows signs of carbon monoxide poisoning. USE AVAILABLE HANDRAILS AND HANDHOLDS while moving about the cabin and while the boat is in motion to avoid falling. U40419-01

4 **WARNING**
Rotating propeller may cause serious injury or death. Shut off engine when near persons in the water. Carbon monoxide (CO) can cause brain damage or death. Engine and generator exhaust contains odorless and colorless carbon monoxide gas. Signs of carbon monoxide poisoning include nausea, headache, dizziness, drowsiness, and lack of consciousness. Get fresh air if anyone shows signs of carbon monoxide poisoning. See Owner's Manual for information regarding carbon monoxide poisoning. Leaking fuel is a fire and explosion hazard. Avoid serious injury or death from fire or explosion from leaking fuel. Inspect system for leaks at least once a year. U36070-01

SEA FOX BOAT COMPANY
MEETS U.S. EPA EVAL STANDARDS USING CERTIFIED COMPONENTS

1 **WARNING**
AVOID PERSONAL INJURY SECURE GATE/DOOR & DO NOT BE OUTSIDE GATE/DOOR WHEN BOAT IS UNDERWAY. U36070-01

1 **WARNING**
WARNING: AVOID SERIOUS INJURY OR DEATH. OCCUPANT MAY FALL OR BE EJECTED FROM SEAT. DO NOT OCCUPY SEAT WHEN SPEED EXCEEDS 5 MPH. U36068-01

1 **WARNING**
WARNING: AVOID SERIOUS INJURY OR DEATH. OCCUPANT MAY FALL OR BE EJECTED FROM SEAT. DO NOT OCCUPY SEAT WHEN SPEED EXCEEDS 5 MPH. U36068-01

4 **WARNING**
Failure to follow these warnings could cause severe injury or death
• WEAR SAFETY LANYARD at all times while operating boat to prevent unmanned boat operation.
• NEVER OPERATE WHILE UNDER THE INFLUENCE of drugs or alcohol.
• DO NOT OVERLOAD THE BOAT. ENSURE THAT WEIGHT IS PROPERLY AND EVENLY DISTRIBUTED fore and aft and on both sides of the boat to avoid poor handling, sudden loss of control, swamping and/or capsizing.
• PASSENGERS SHOULD WEAR U.S. COAST GUARD APPROVED LIFE JACKETS.
• MAKE SURE THAT ALL PASSENGERS ARE PROPERLY SEATED WHILE UNDERWAY. To avoid passengers falling overboard or being ejected from the boat, do not allow passengers to sit on seat backs, gunwales or outermost deck edges while boat is moving.
• REDUCE SPEED BEFORE ATTEMPTING SUDDEN OR SHARP TURNS.
• AND MAINTAIN SAFE SPEEDS for water conditions and environment at all times. Maneuverability at high speeds is limited, and sudden turns may cause loss of boat control.
• KEEP PROPER LOOKOUT AND SAFE DISTANCE for the conditions at all times to avoid collisions.
• OBEY APPLICABLE NAVIGATION RULES AND BOATING LAWS.
• USE CAUTION AND PROPER LIGHTING during nighttime boating and boating in adverse weather.
• READ THE OWNER'S MANUAL AND COMPLETE THE BOATER'S PRE-OPERATION CHECKLIST prior to boat operation. U40420-01

6 **NOTICE**
THIS BOAT IS EQUIPPED WITH AN OPTIONAL DIRECT OVERBOARD DISCHARGE VALVE. DISCHARGING OF SEWAGE DIRECTLY OVERBOARD IS FOR USE WHERE APPROVED ONLY. U36419-01

6 **NOTICE**
SHUT OFF VALVE(S) LOCATED BEHIND ACCESS PANEL. CLOSE VALVE(S) WHEN NOT IN USE. U37620-02

230350 251 Bay Fox Decal Kit Rev 2

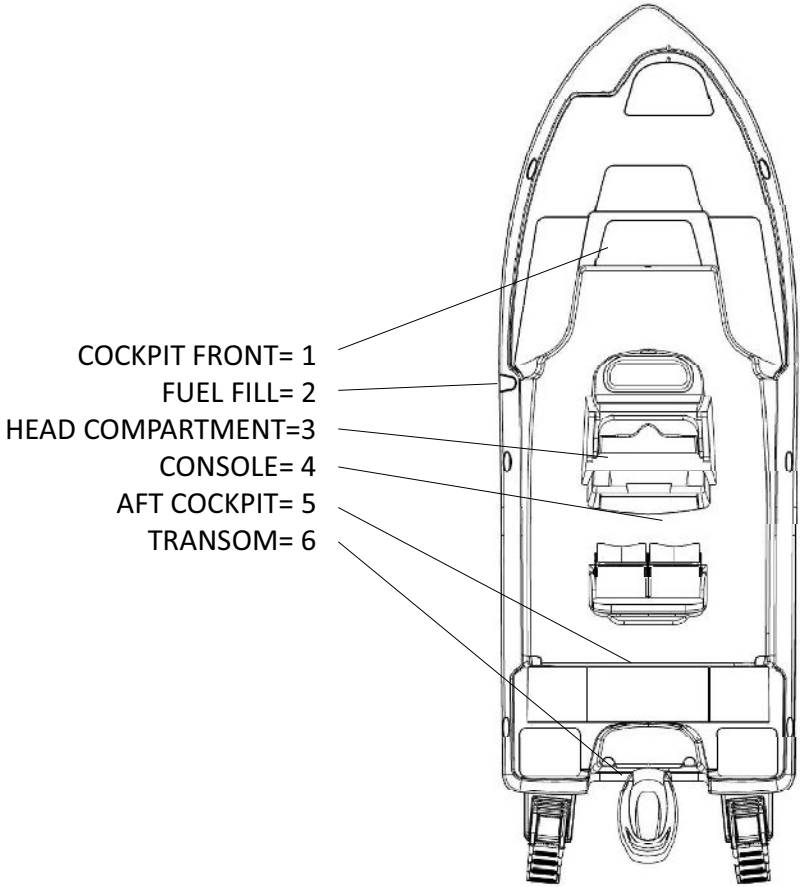

PLUMBING SCHEMATICS

BILGE SYSTEM

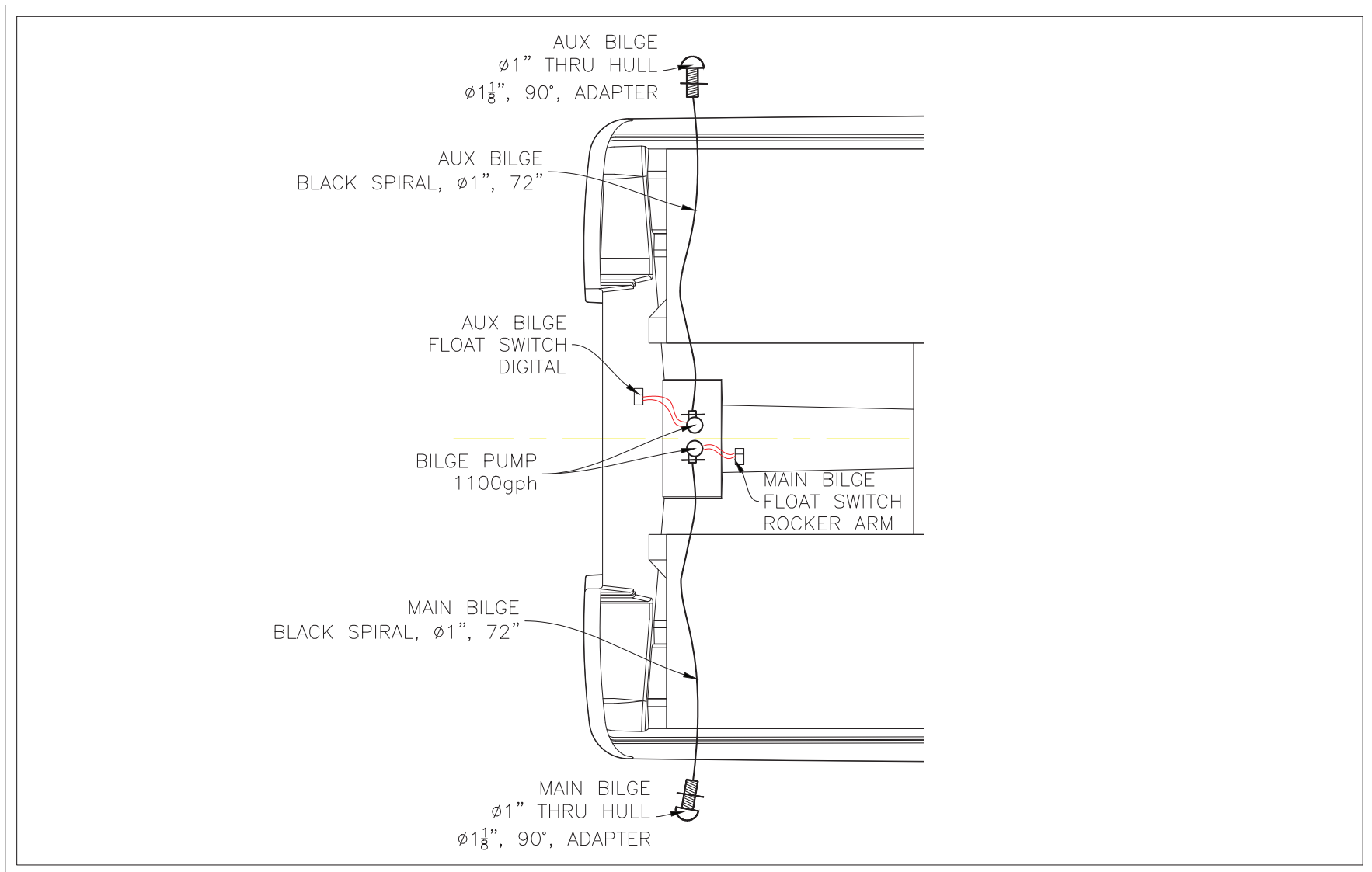

DRAINS

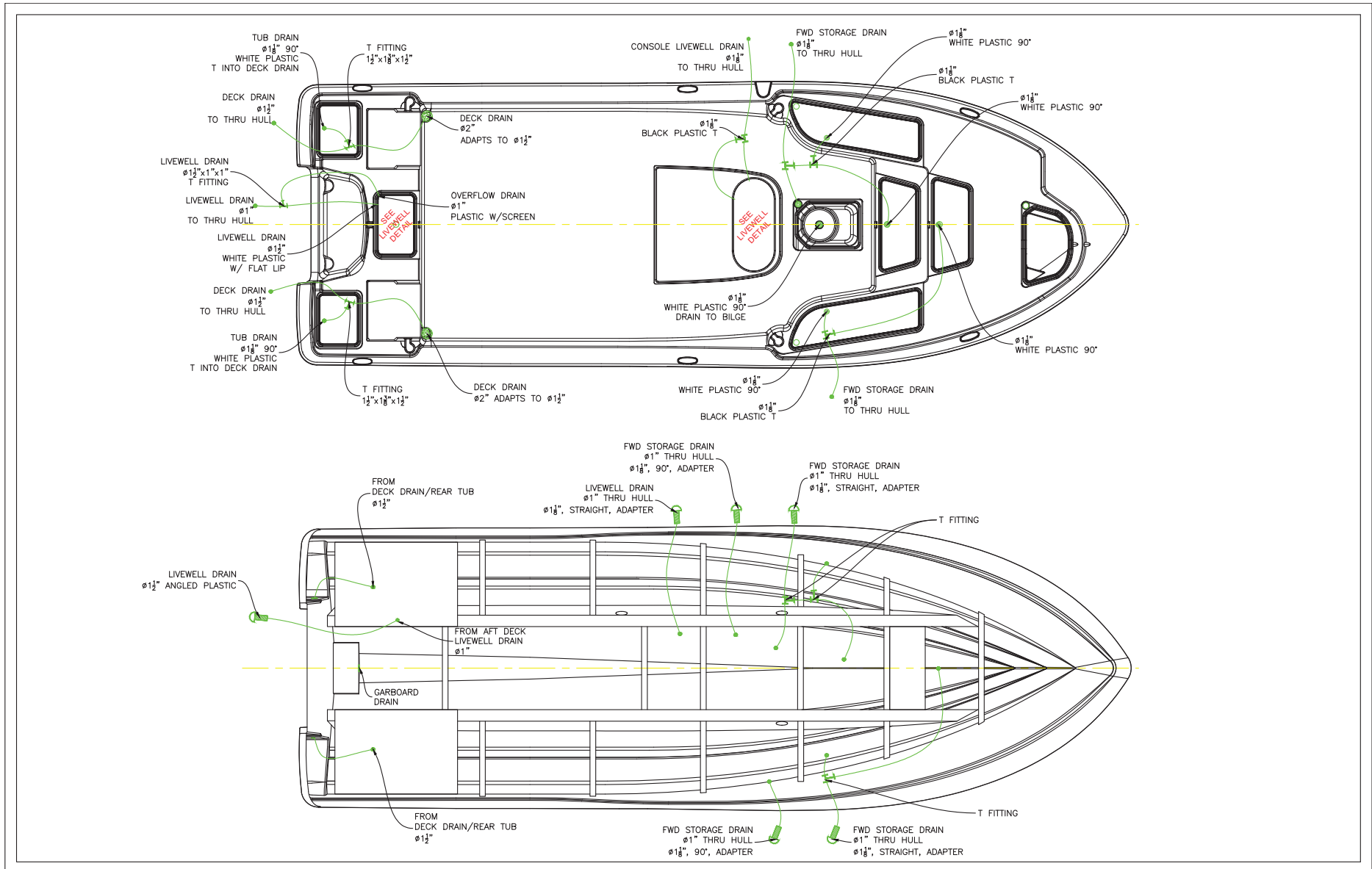

DRAINS (CONTINUED)

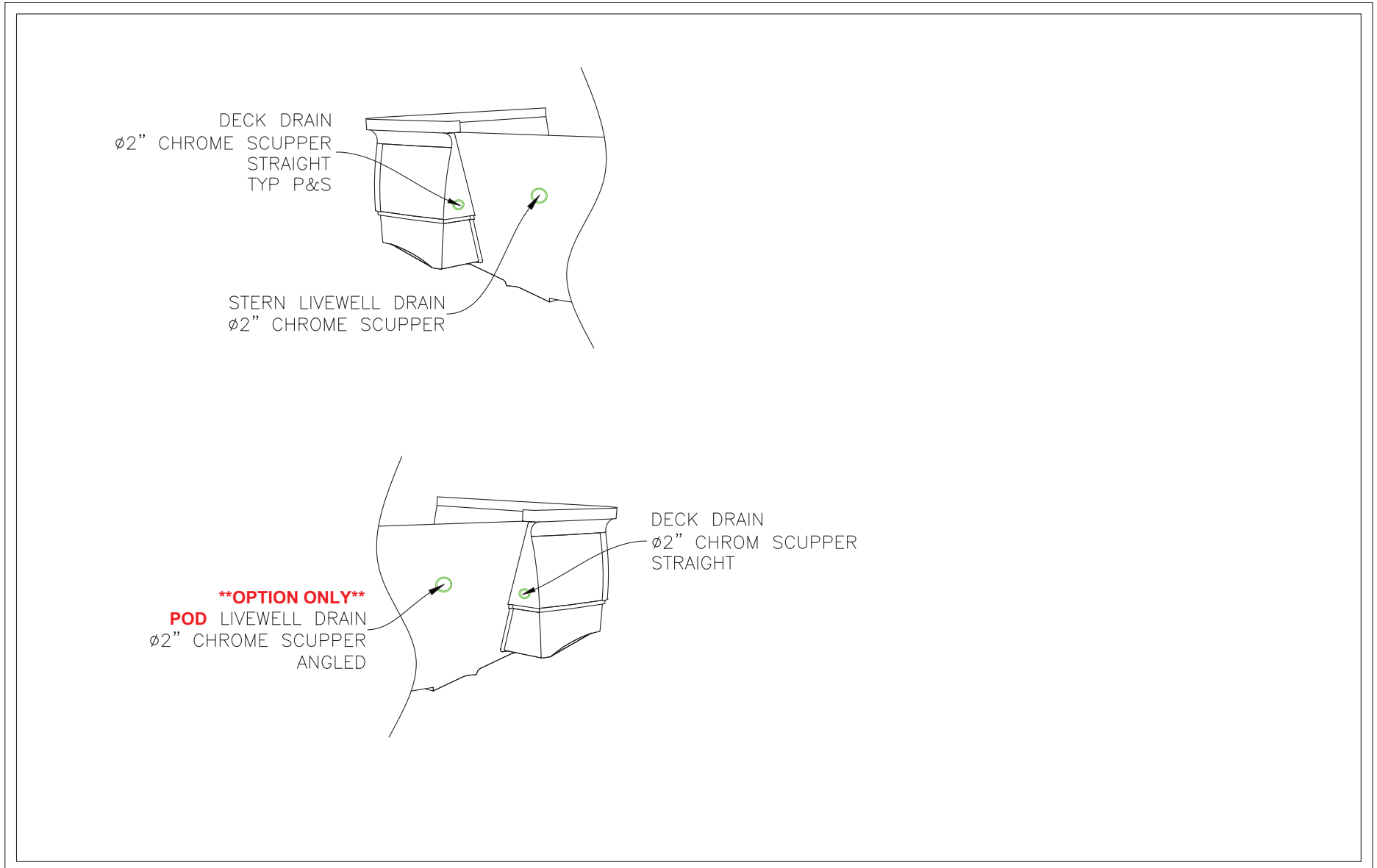

FRESH WATER SYSTEM

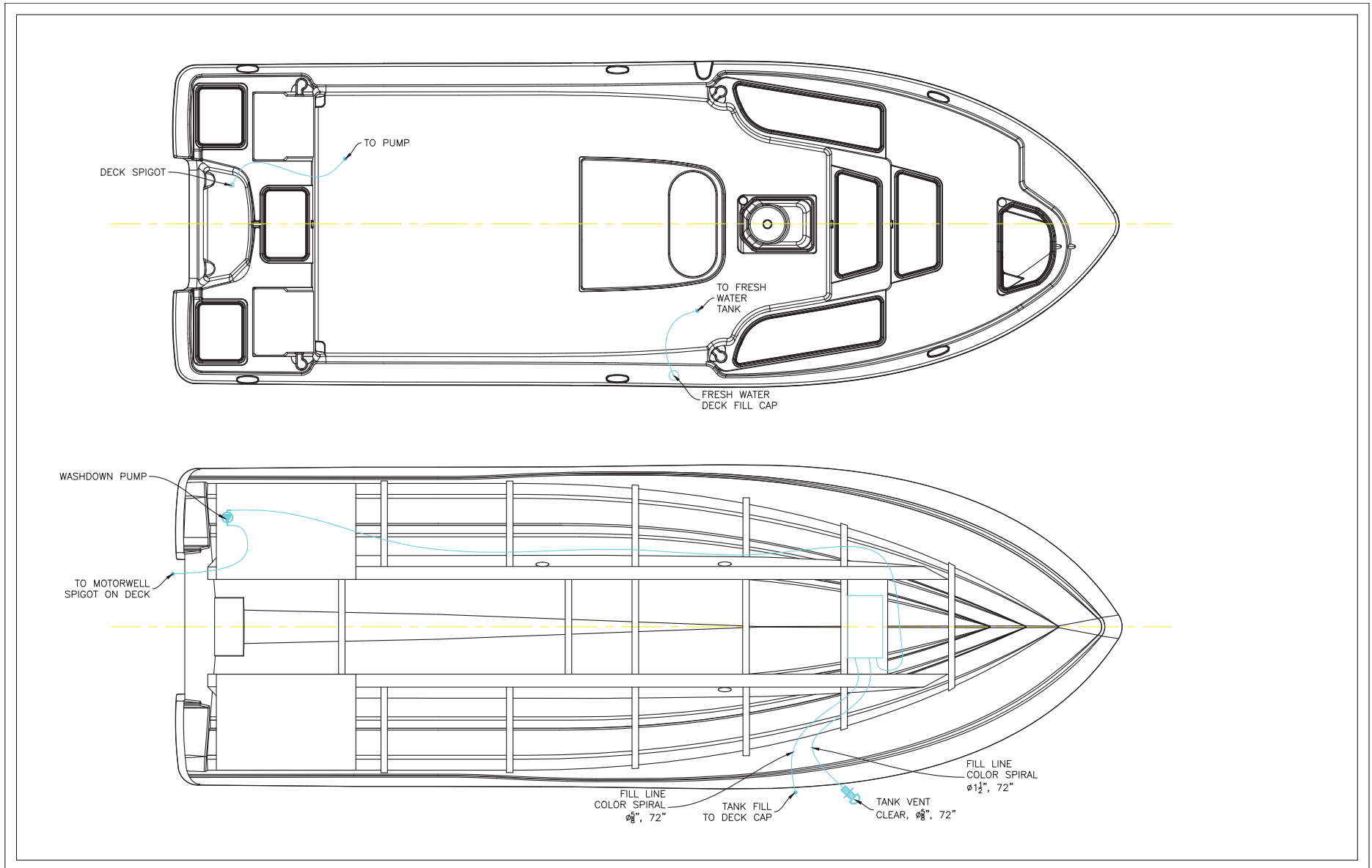

FUEL SYSTEM

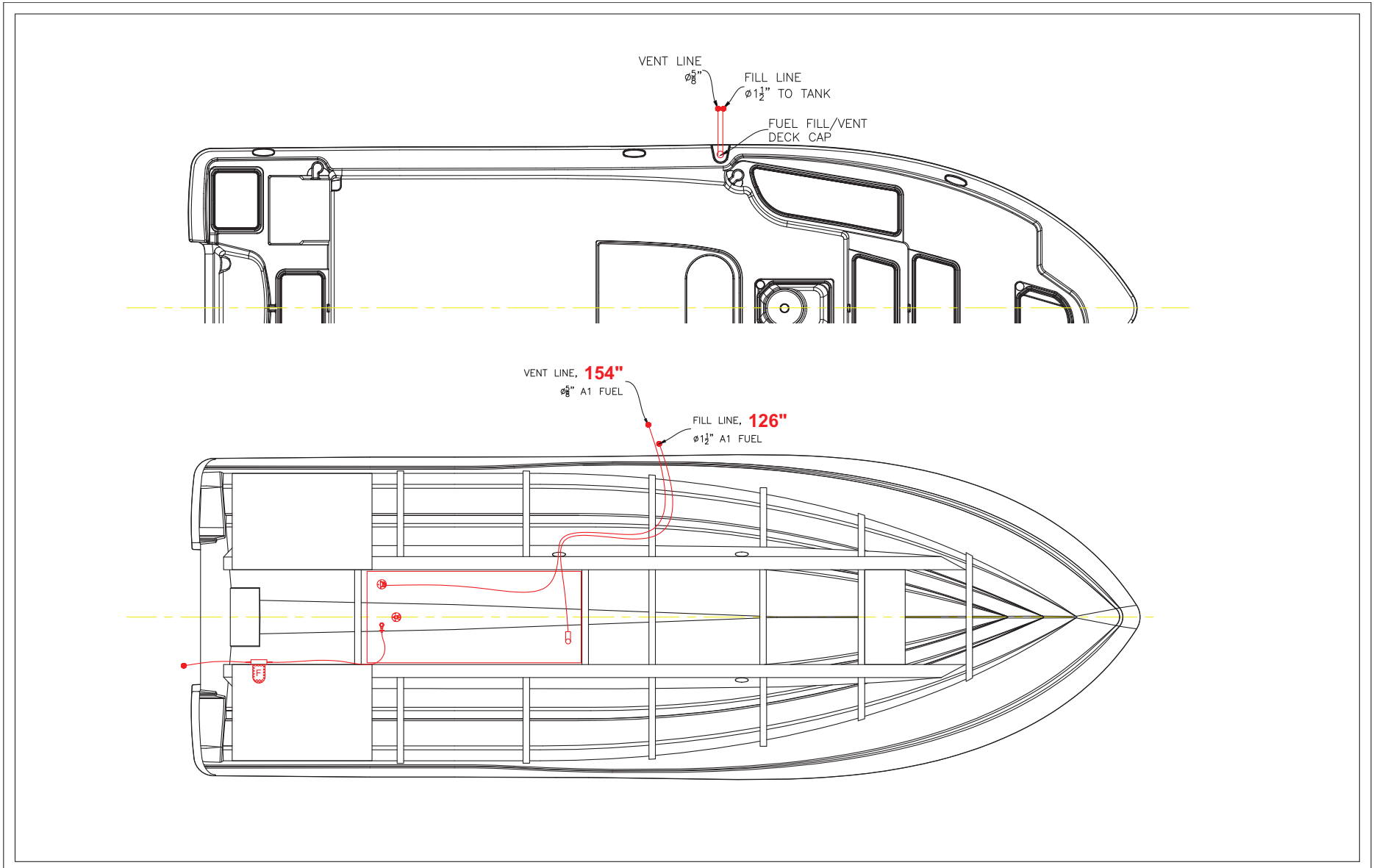

STANDARD LIVEWELL SYSTEM

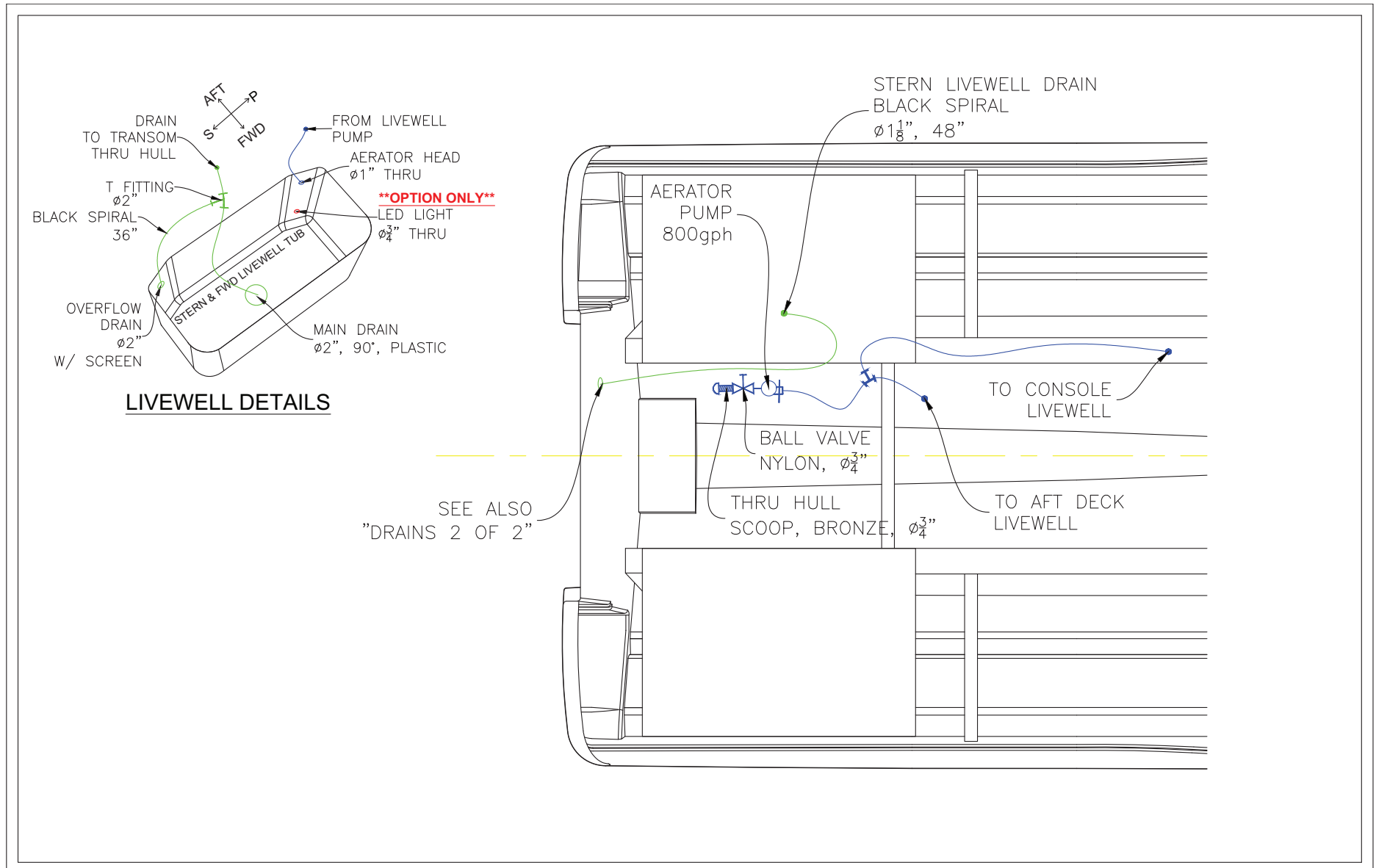

MISTER SYSTEM

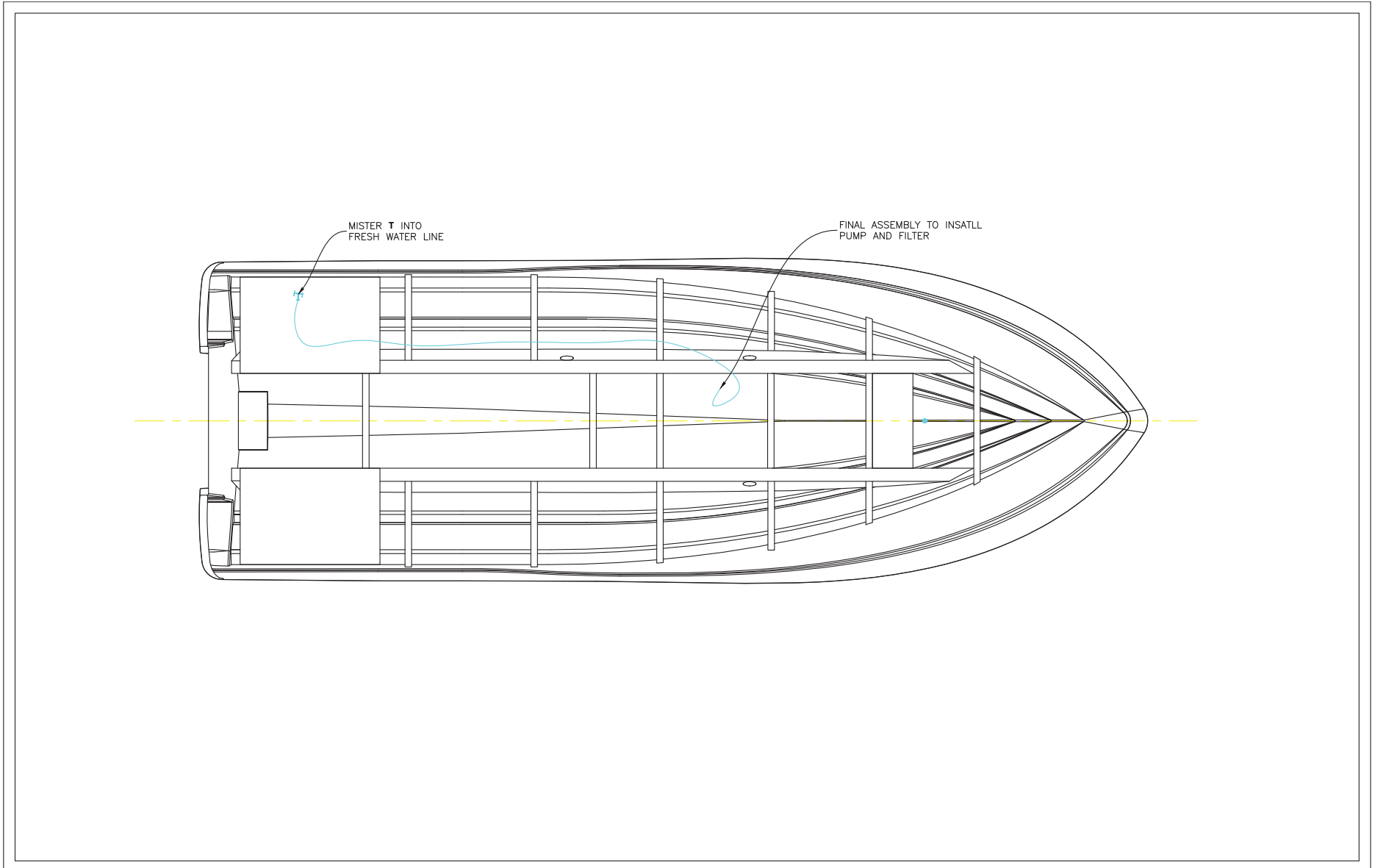

POD LIVEWELL SYSTEM

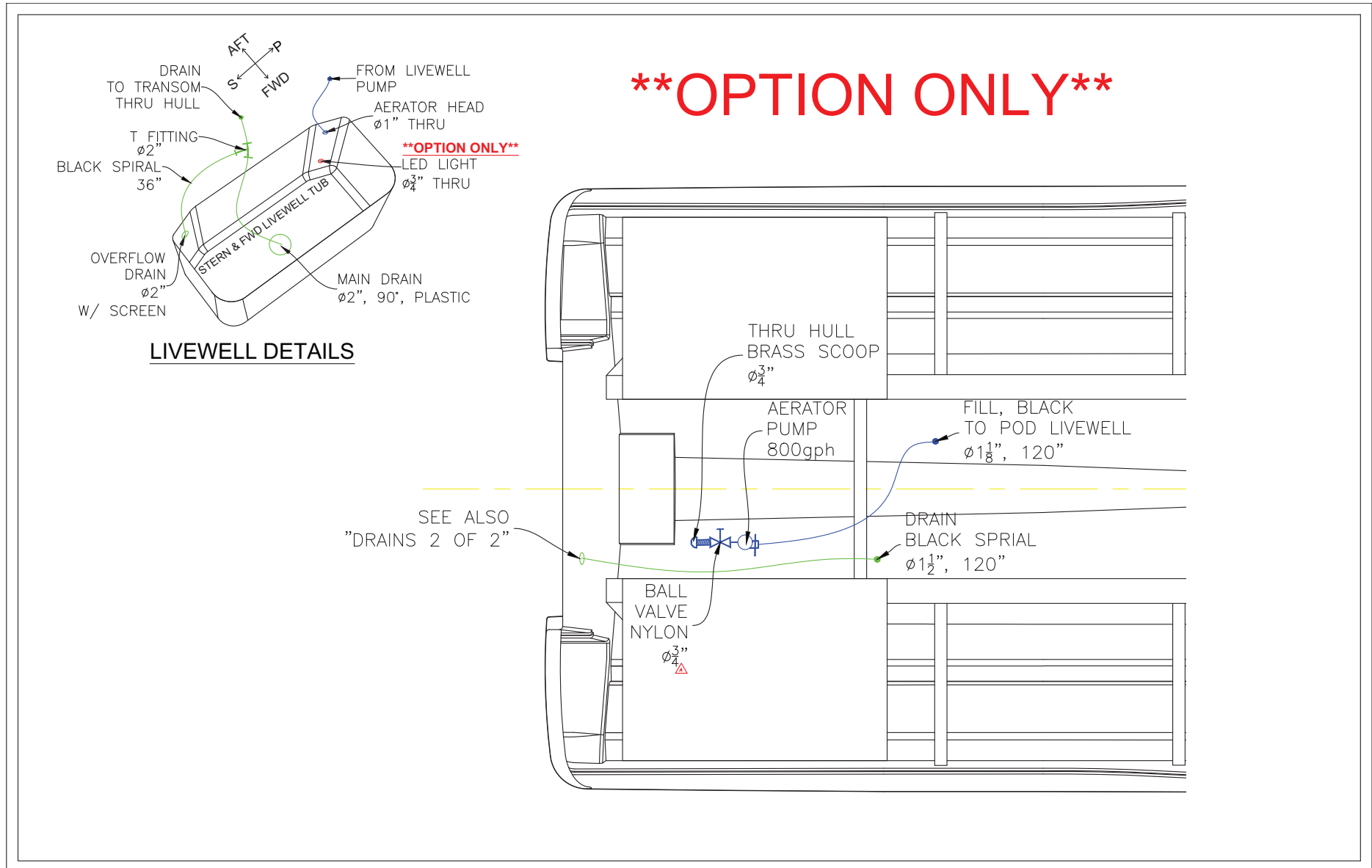

RAW WATER SYSTEM

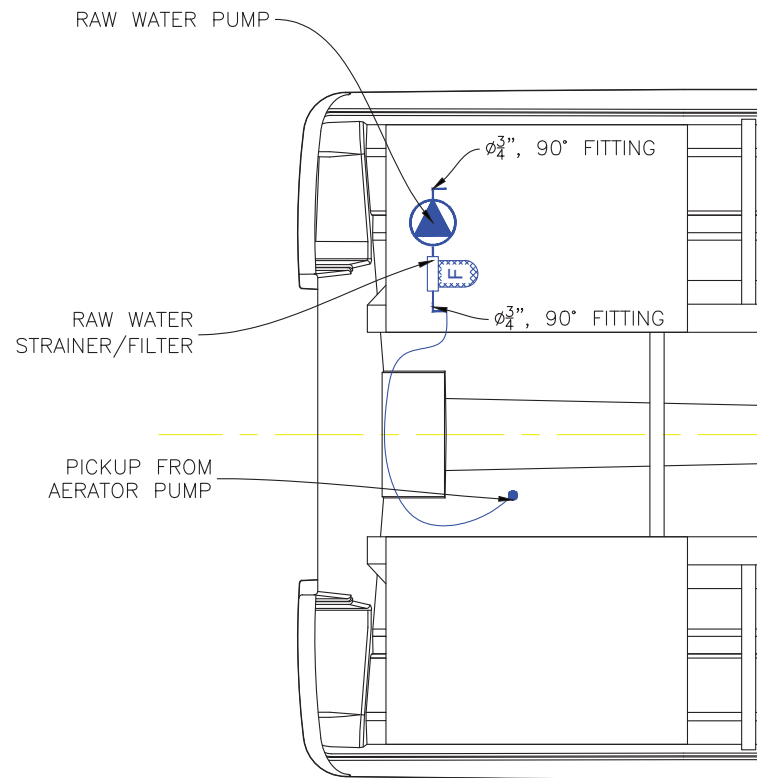

ELECTRICAL SCHEMATICS

TYPICAL 2-BATTERY SETUP IN CONSOLE

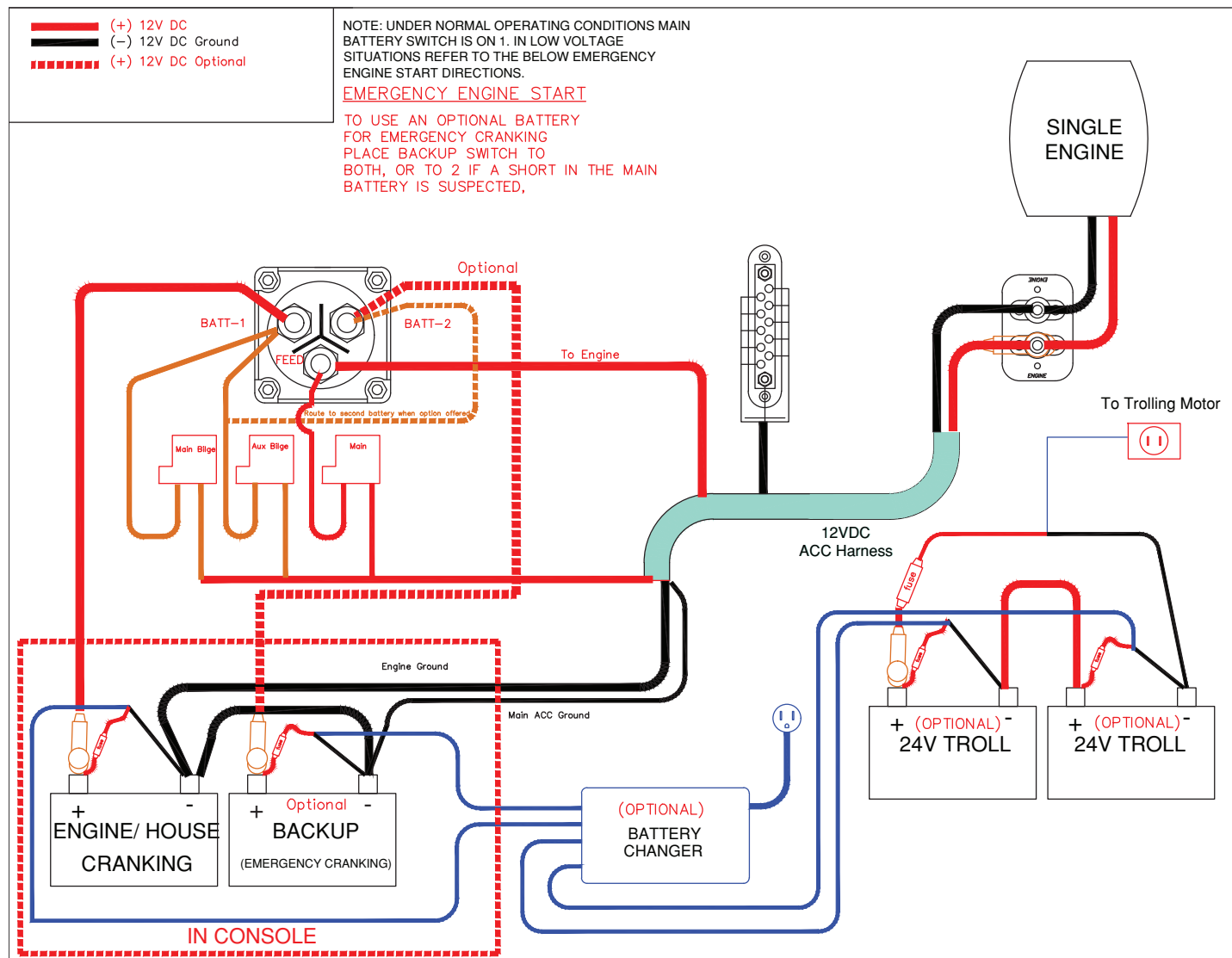

HARNESS TROLLING MOTOR 180-240 (P/N 4823)

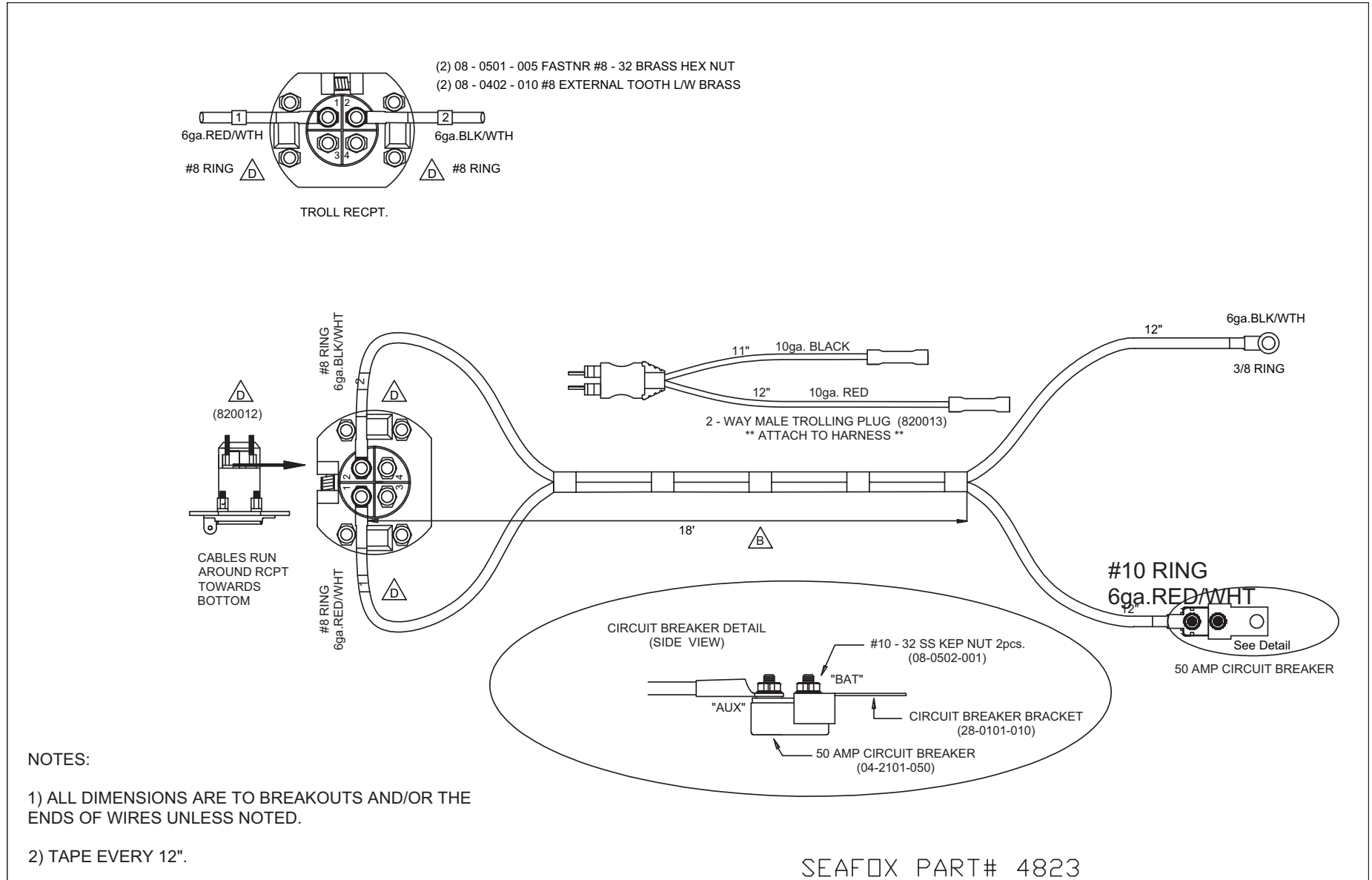

HARNES ACC W/DEUTSCH (P/N 6402)

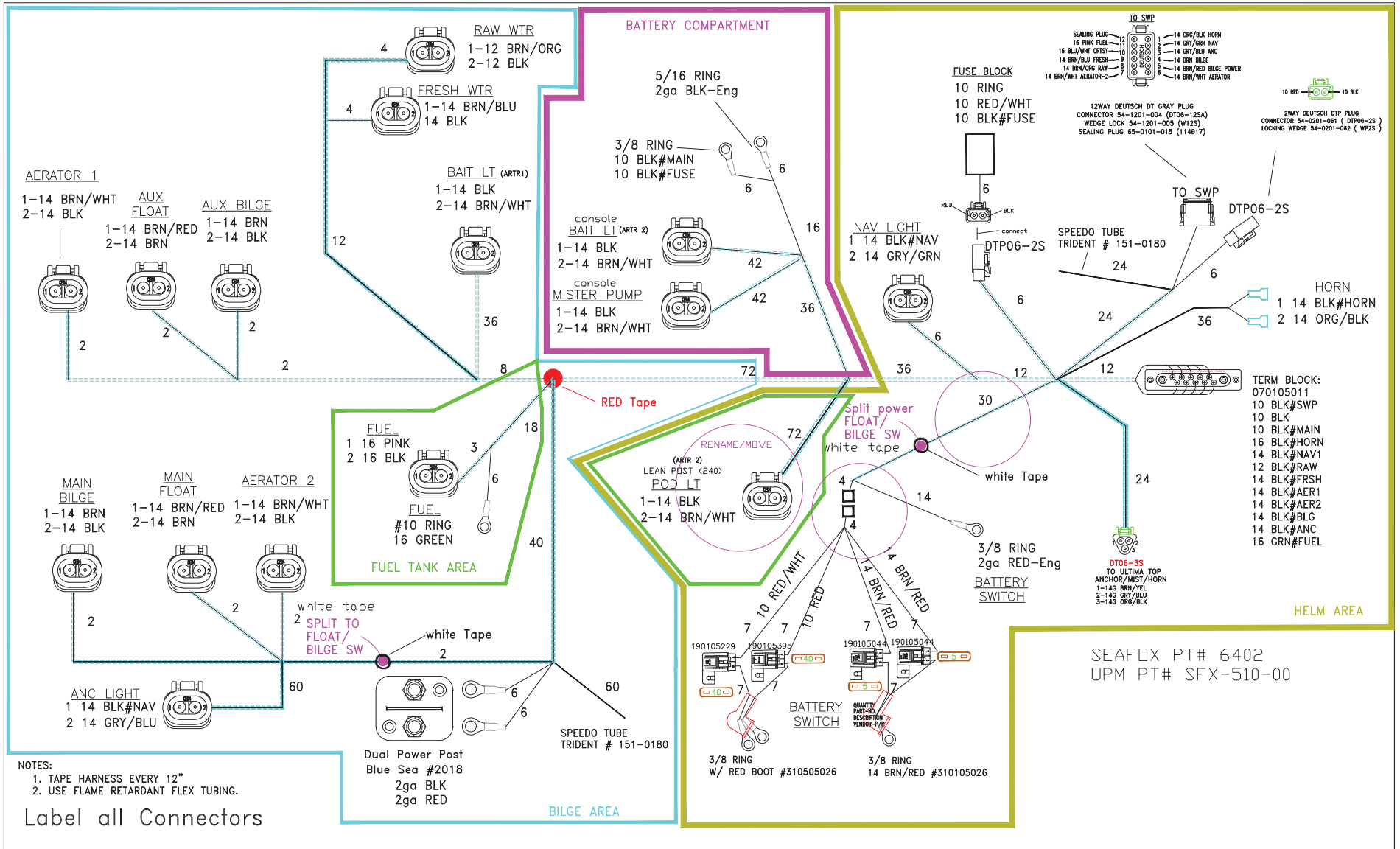

PANEL SWITCH SHROUD (P/N 6510)

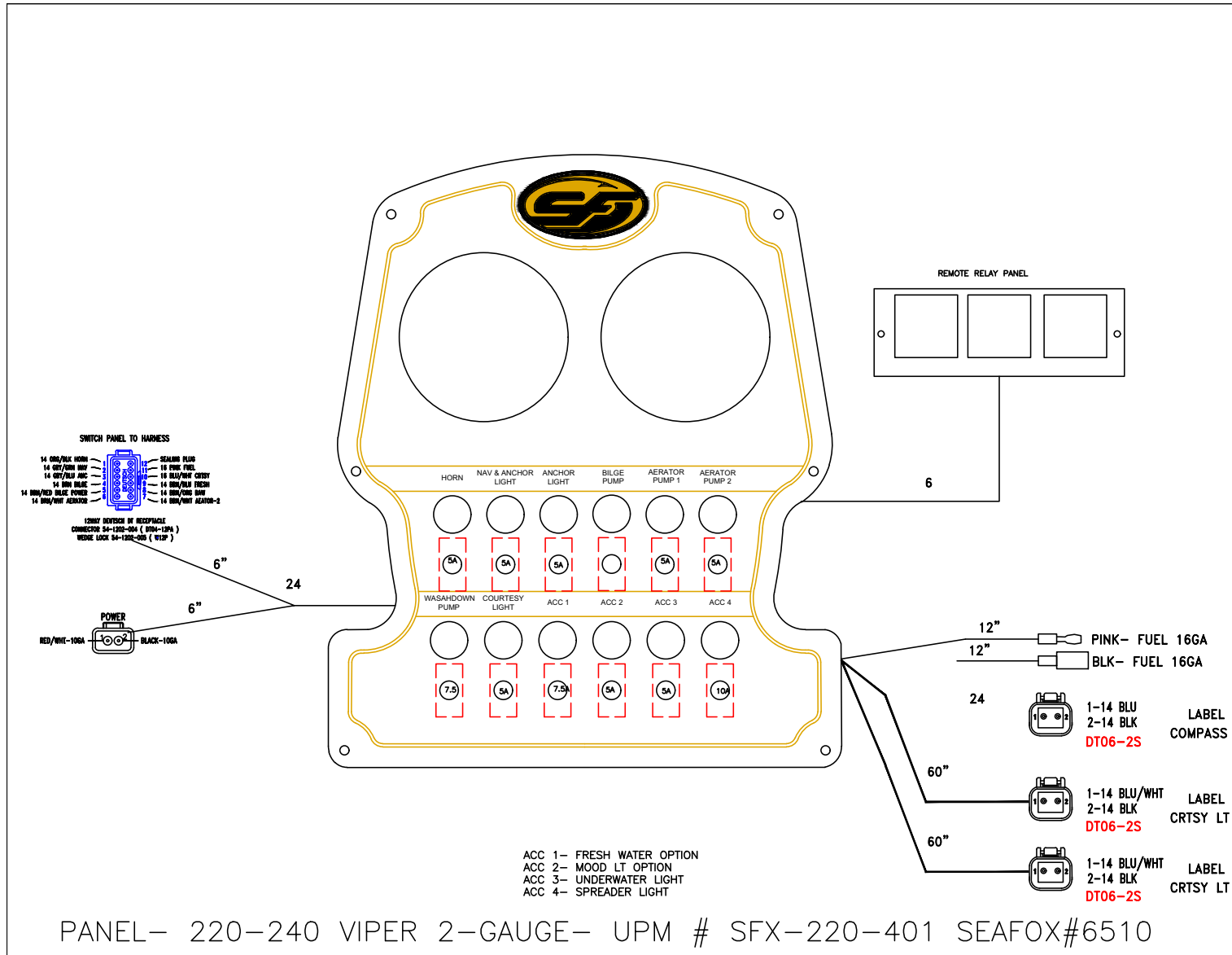

HARNES NAV SHORT

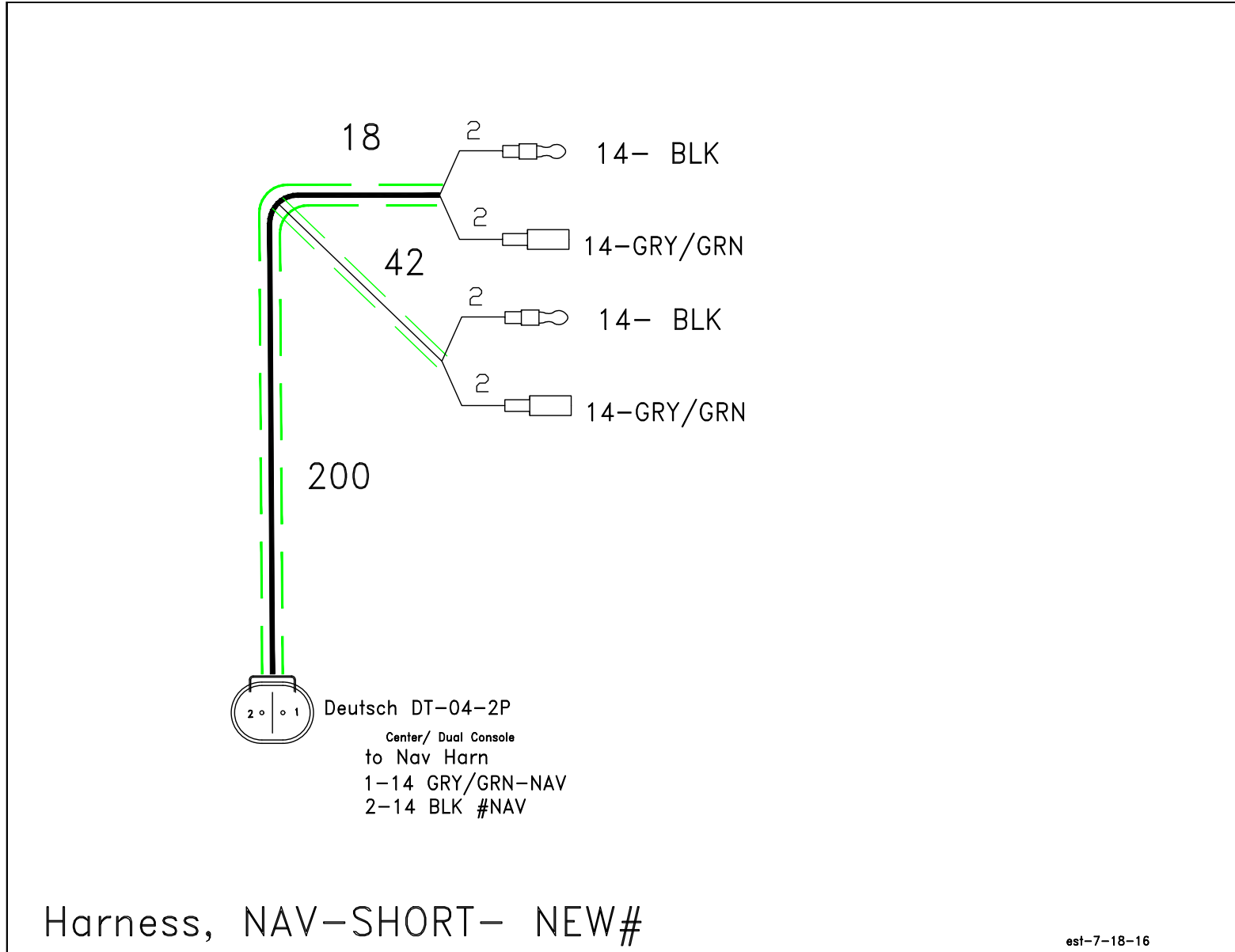

TRIMTABS ELECTRICAL SWITCH STANDARD (P/N 2895) – OPTIONAL

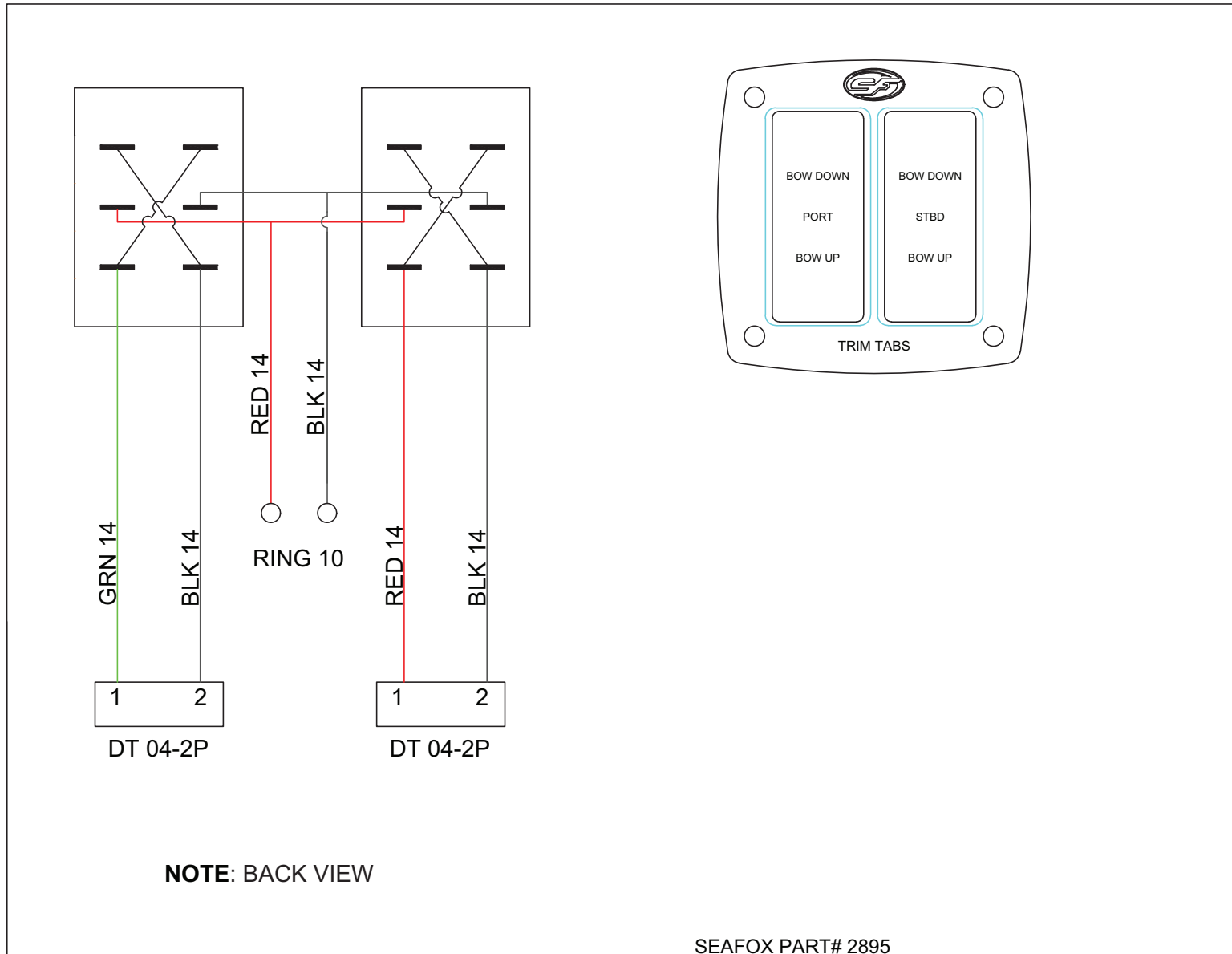

HARNESS MOOD LIGHT W/DEUTSCH (P/N 6128) – OPTIONAL

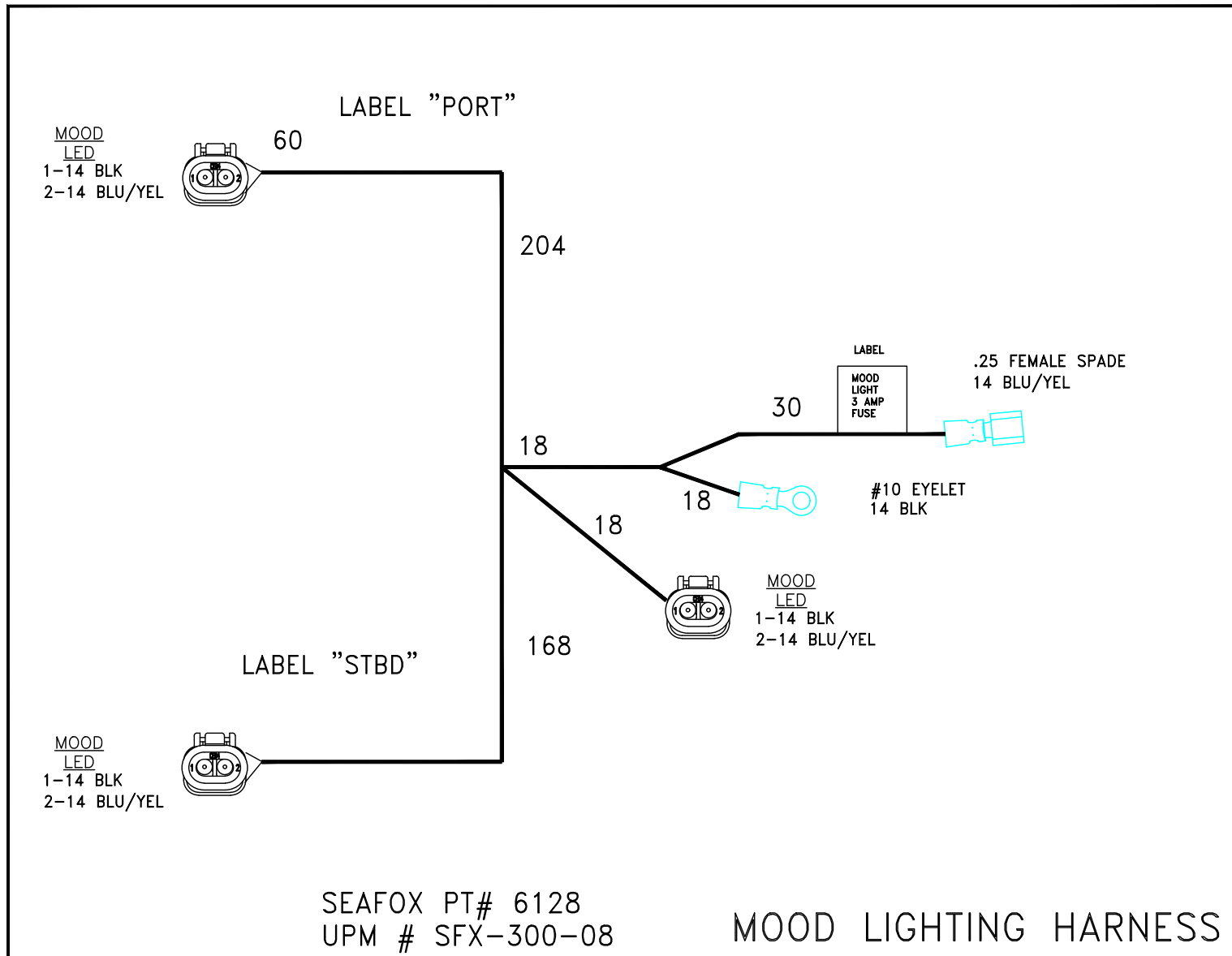

HARNES STEREO INFINITY CON (P/N 6129) – OPTIONAL

CUSTOMER SEAFOX BOAT CO. W/O # _____
 PART # 6129 UPM# SFX-300-09 DUE DATE _____
 FILENAME _____ MODEL ALL MODELS
 DESCRIPTION HARNES STEREO INFINITY/JENSEN

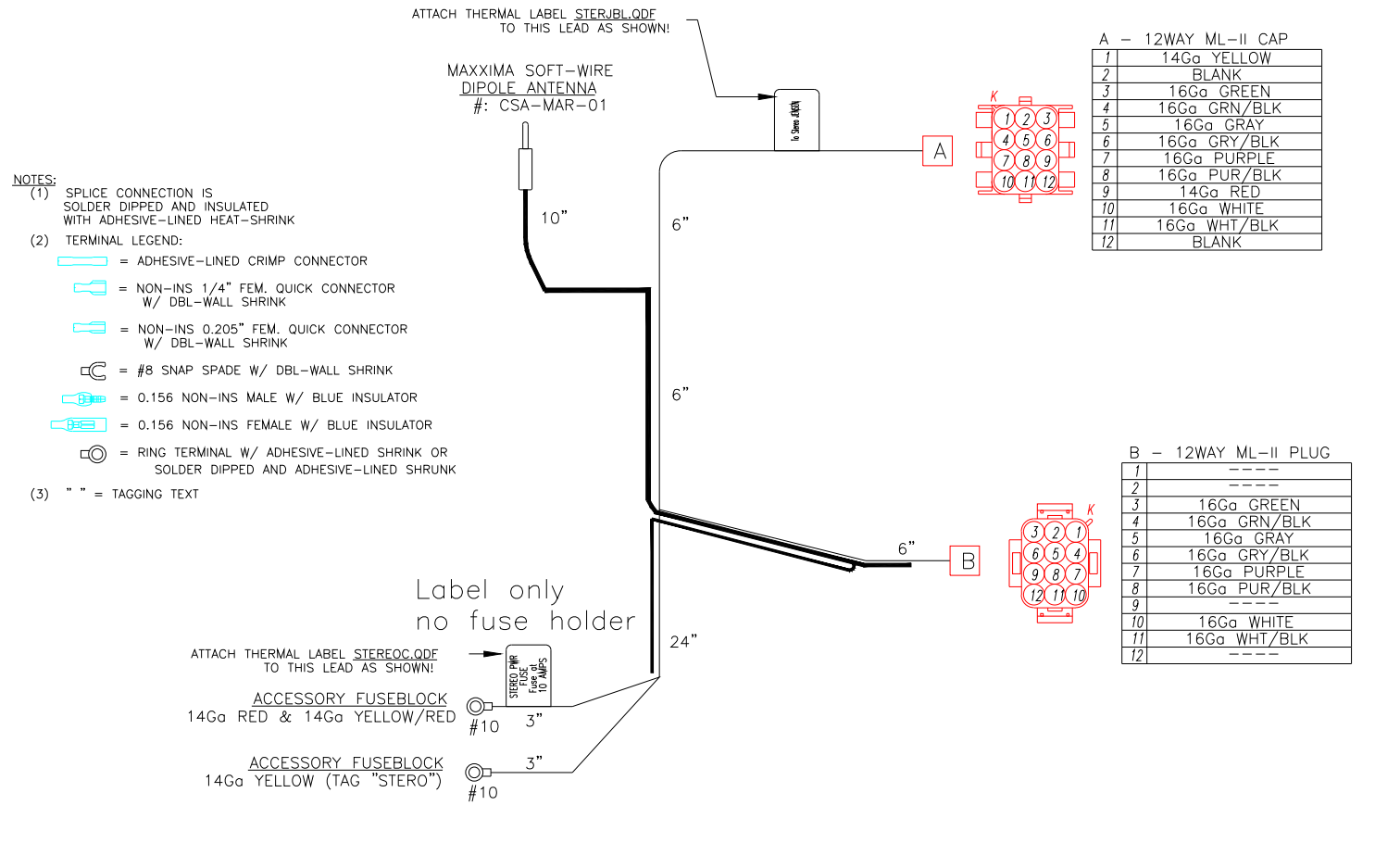

HARNES STEREO INFINITY DECK (P/N 6130) – OPTIONAL

CUSTOMER SEAFOX BOAT CO.

PART # 6130 UPM# SFX-300-04

FILENAME _____

W/O # _____

DUE DATE _____

MODEL ALL MODELS

DESCRIPTION HARNES DECK INFINITY STEREO

NOTES:

 = NON-INS 1/4" FEM. QUICK CONNECTOR
W/ DBL-WALL SHRINK

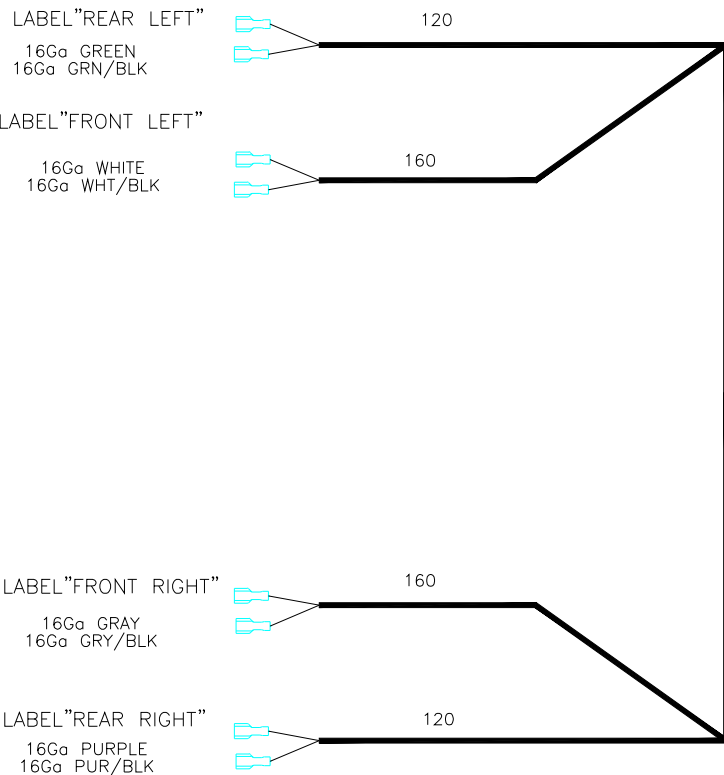

B - 12WAY ML-II PLUG

1	----
2	----
3	16Ga GREEN
4	16Ga GRN/BLK
5	16Ga GRAY
6	16Ga GRY/BLK
7	16Ga PURPLE
8	16Ga PUR/BLK
9	----
10	16Ga WHITE
11	16Ga WHT/BLK
12	----

HARNES UNDERWATER LIGHT W/DEUTSCH (P/N 6133) – OPTIONAL

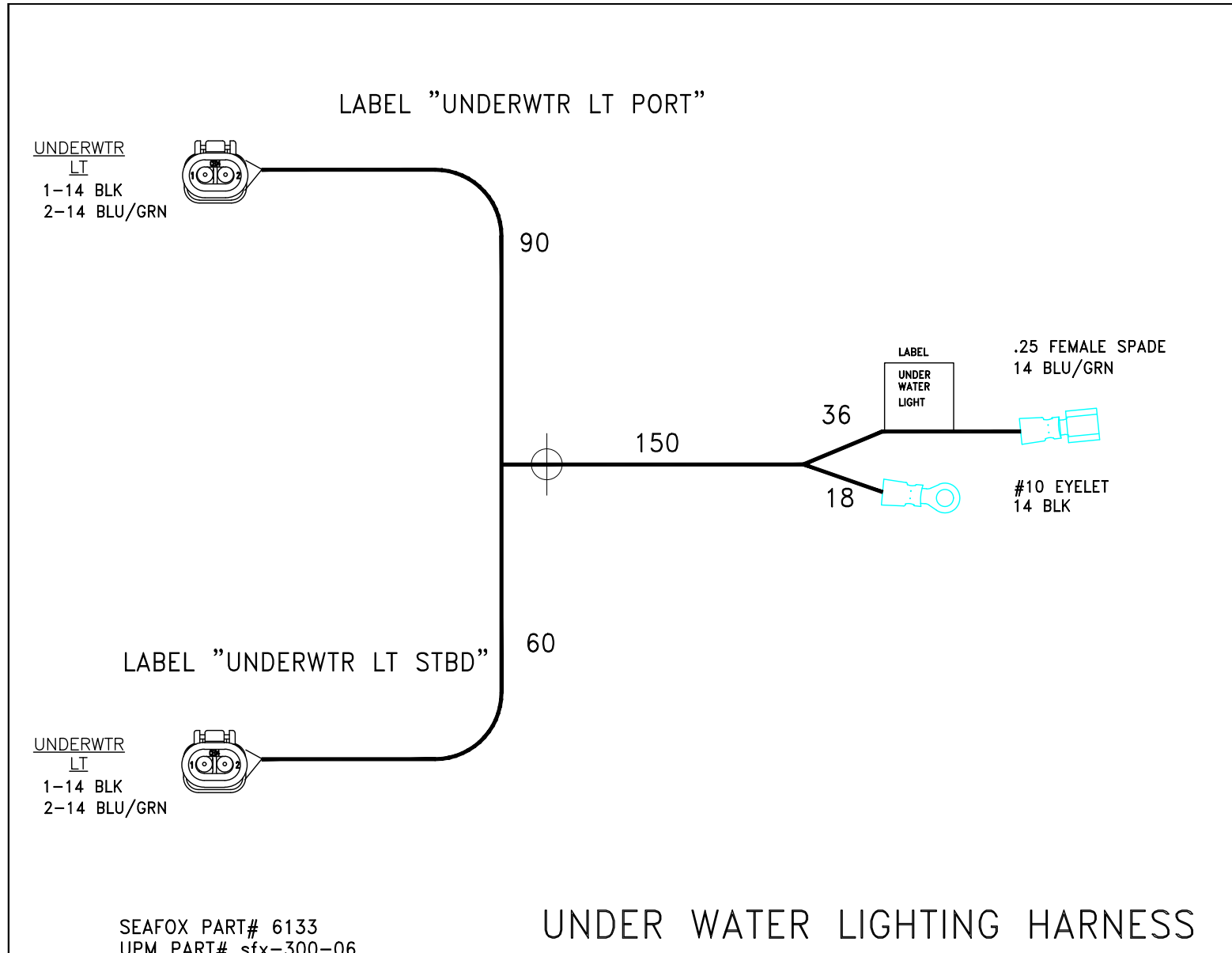

U PANEL SWITCH ULTIMA (P/N 6463) – OPTIONAL

SEAFOX PT# 6463
UPM PT# SFX-600-40

3 OF 3

"J"-FROM SWITCH PANEL

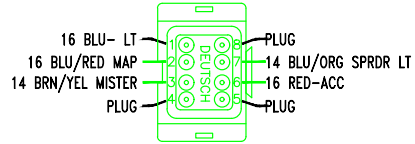

8WAY DEUTSCH DT RECEPTACLE
CONNECTOR 54-0802-008 (DT04-8PA)
WEDGE LOCK 54-0801-009 (W8P)

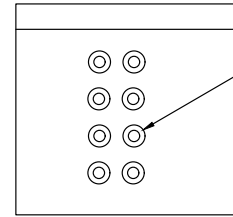

SHIP WITH SWP ASSEMBLY:
081401002 (8) SHOULDER WASHER
IN 4 X 4 PLASTIC BAG

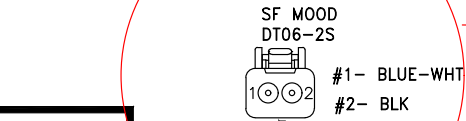

add

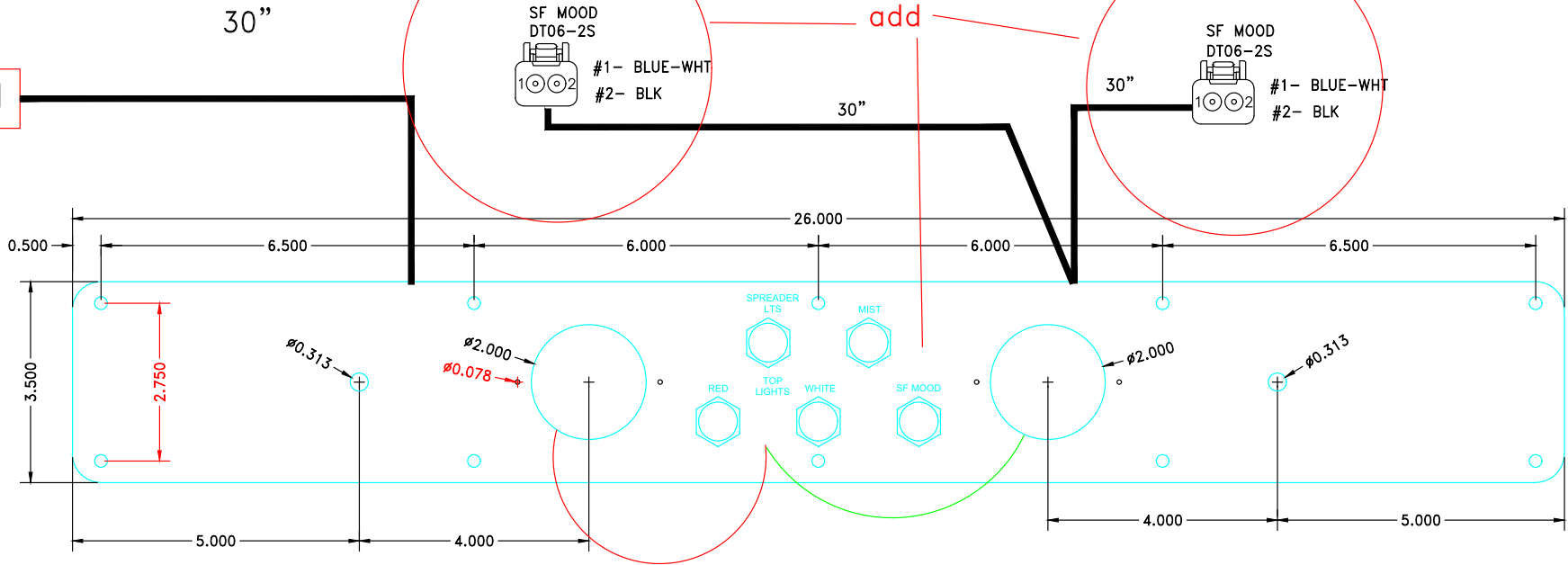
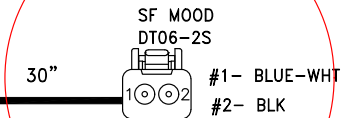

CENTER CONSOLE ULTIMA TOP – 2016 (P/N 6463, 6464 AND 6476) – OPTIONAL

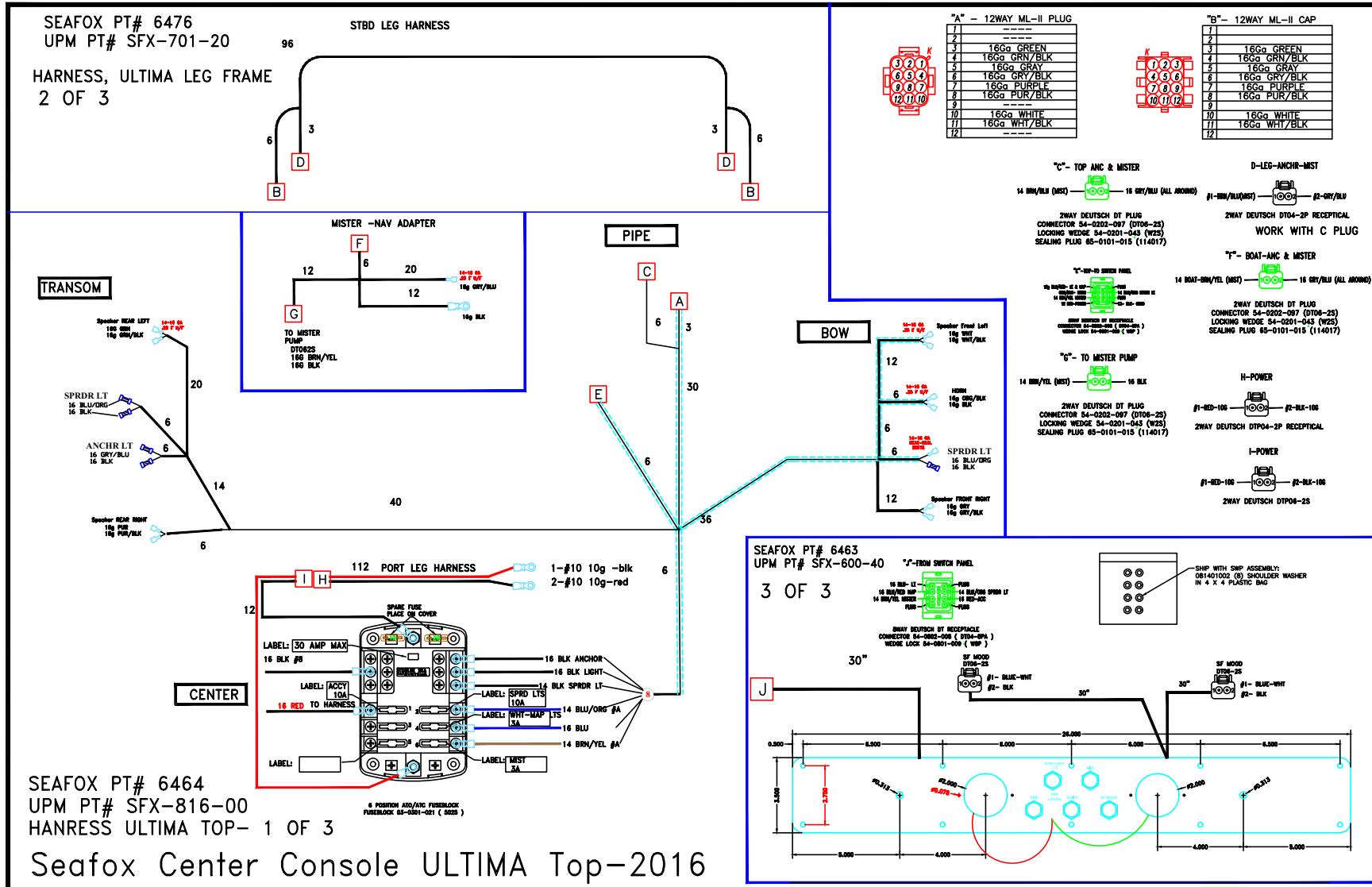

HARNESS TRIMTAB ELECTRIC 20 FT Lenco (P/N 6564) – OPTIONAL

SEAFOX PT#:6564
UPM PT# SFX-050-020

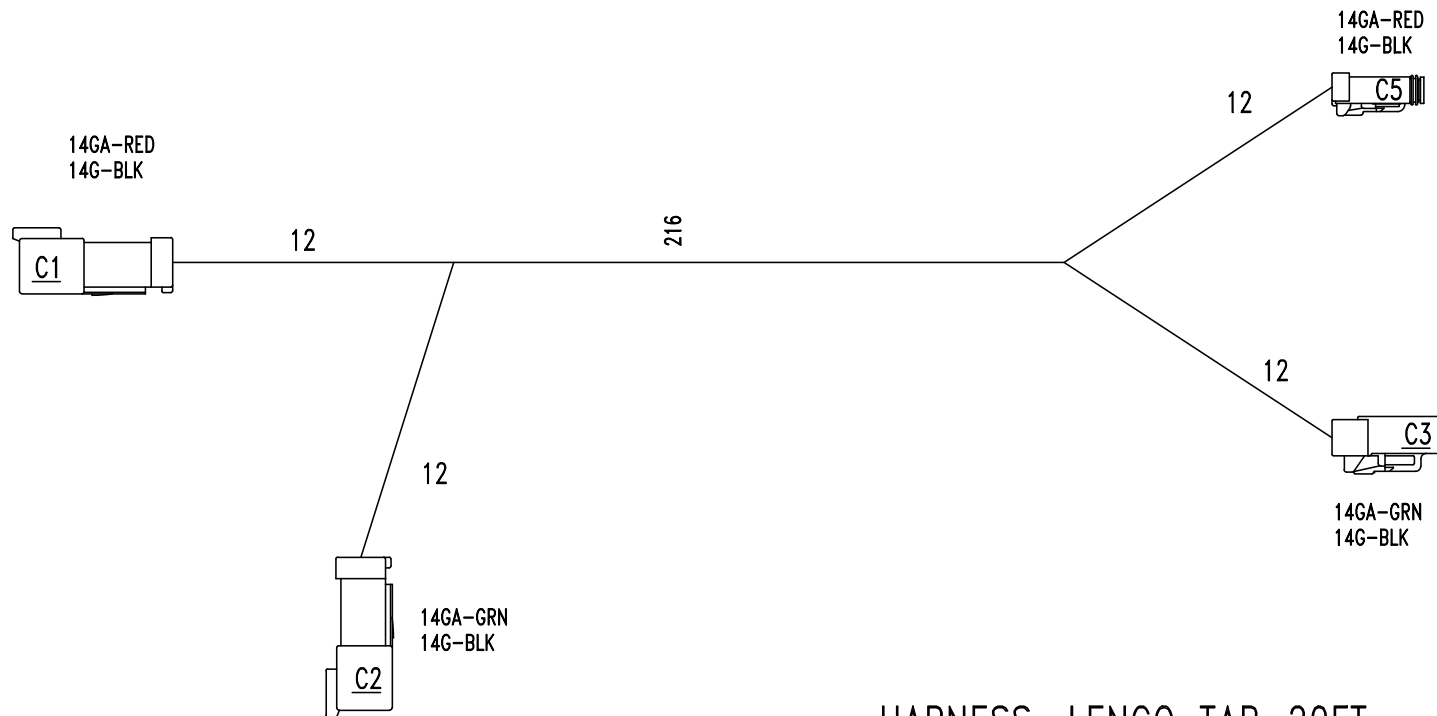

HARNESS, Lenco TAB-20FT

HARNES STEREO KICKER CON 2016 (P/N 6851) – OPTIONAL

NOTES:

- (1) SPLICE CONNECTION IS SOLDER DIPPED AND INSULATED WITH ADHESIVE-LINED HEAT-SHRINK
- (2) TERMINAL LEGEND:
- = ADHESIVE-LINED CRIMP CONNECTOR
 - = NON-INS 1/4" FEM. QUICK CONNECTOR W/ DBL-WALL SHRINK
 - = NON-INS 0.205" FEM. QUICK CONNECTOR W/ DBL-WALL SHRINK
 - = #8 SNAP SPADE W/ DBL-WALL SHRINK
 - = 0.156 NON-INS MALE W/ BLUE INSULATOR
 - = 0.156 NON-INS FEMALE W/ BLUE INSULATOR
 - = RING TERMINAL W/ ADHESIVE-LINED SHRINK OR SOLDER DIPPED AND ADHESIVE-LINED SHRUNK
- (3) " " = TAGGING TEXT

B - 12WAY ML-II PLUG

1	----
2	----
3	16Ga GREEN
4	16Ga GRN/BLK
5	16Ga GRAY
6	16Ga GRY/BLK
7	16Ga PURPLE
8	16Ga PUR/BLK
9	----
10	16Ga WHITE
11	16Ga WHT/BLK
12	----

TO- ULTIMA TOP HARNESS

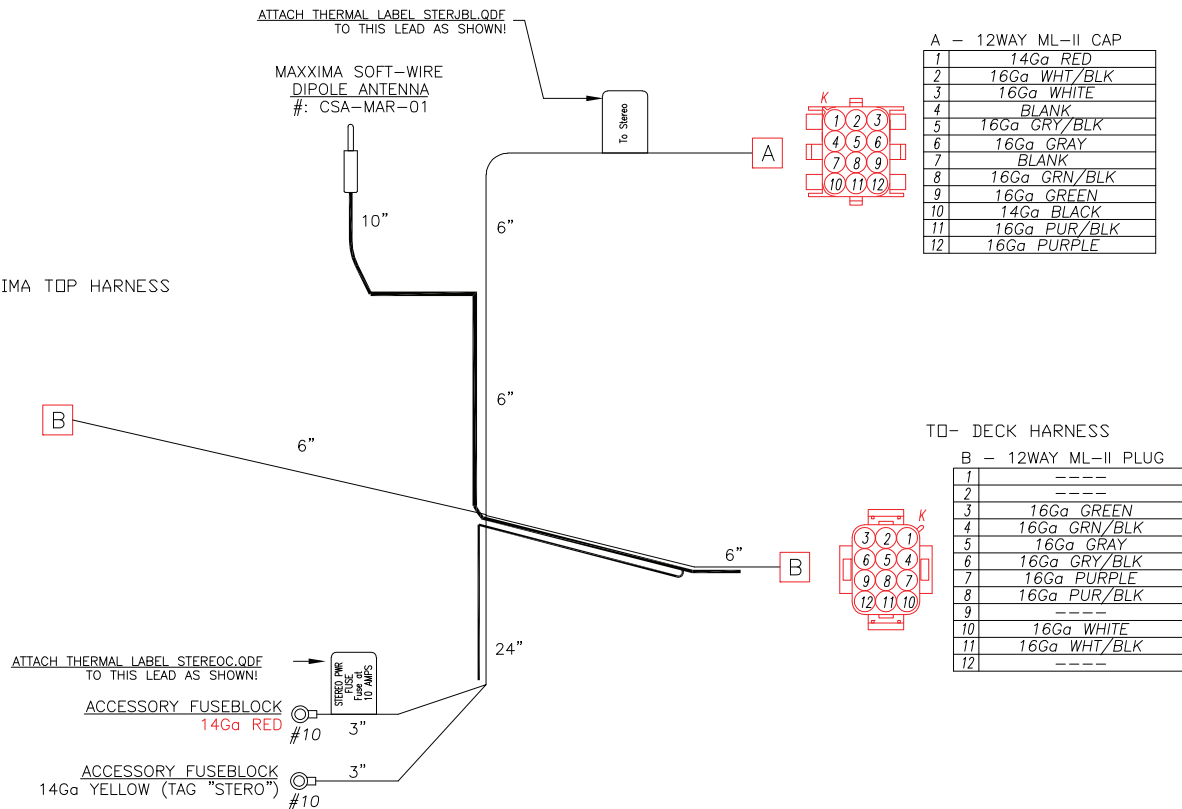

A - 12WAY ML-II CAP

1	14Ga RED
2	16Ga WHT/BLK
3	16Ga WHITE
4	BLANK
5	16Ga GRY/BLK
6	16Ga GRAY
7	BLANK
8	16Ga GRN/BLK
9	16Ga GREEN
10	14Ga BLACK
11	16Ga PUR/BLK
12	16Ga PURPLE

TO- DECK HARNESS

B - 12WAY ML-II PLUG



1	----
2	----
3	16Ga GREEN
4	16Ga GRN/BLK
5	16Ga GRAY
6	16Ga GRY/BLK
7	16Ga PURPLE
8	16Ga PUR/BLK
9	----
10	16Ga WHITE
11	16Ga WHT/BLK
12	----

SEAFXDX PT# 6851

HARNES STEREO KICKER DECK 2016 (P/N 6852) – OPTIONAL

CUSTOMER SEAFOX BOAT CO. W/O # _____
 PART # SF# 6852-UPM# SFX-489-13 DUE DATE _____
 FILENAME _____ MODEL ALL CENTER CONSOLES
 DESCRIPTION HARNES DECK SPEAKER W/LED

NOTES:

-  = NON-INS 1/4" FEM. QUICK CONNECTOR W/ DBL-WALL SHRINK
-  = NON-INS BUTT CONNECTOR W/ DBL-WALL SHRINK

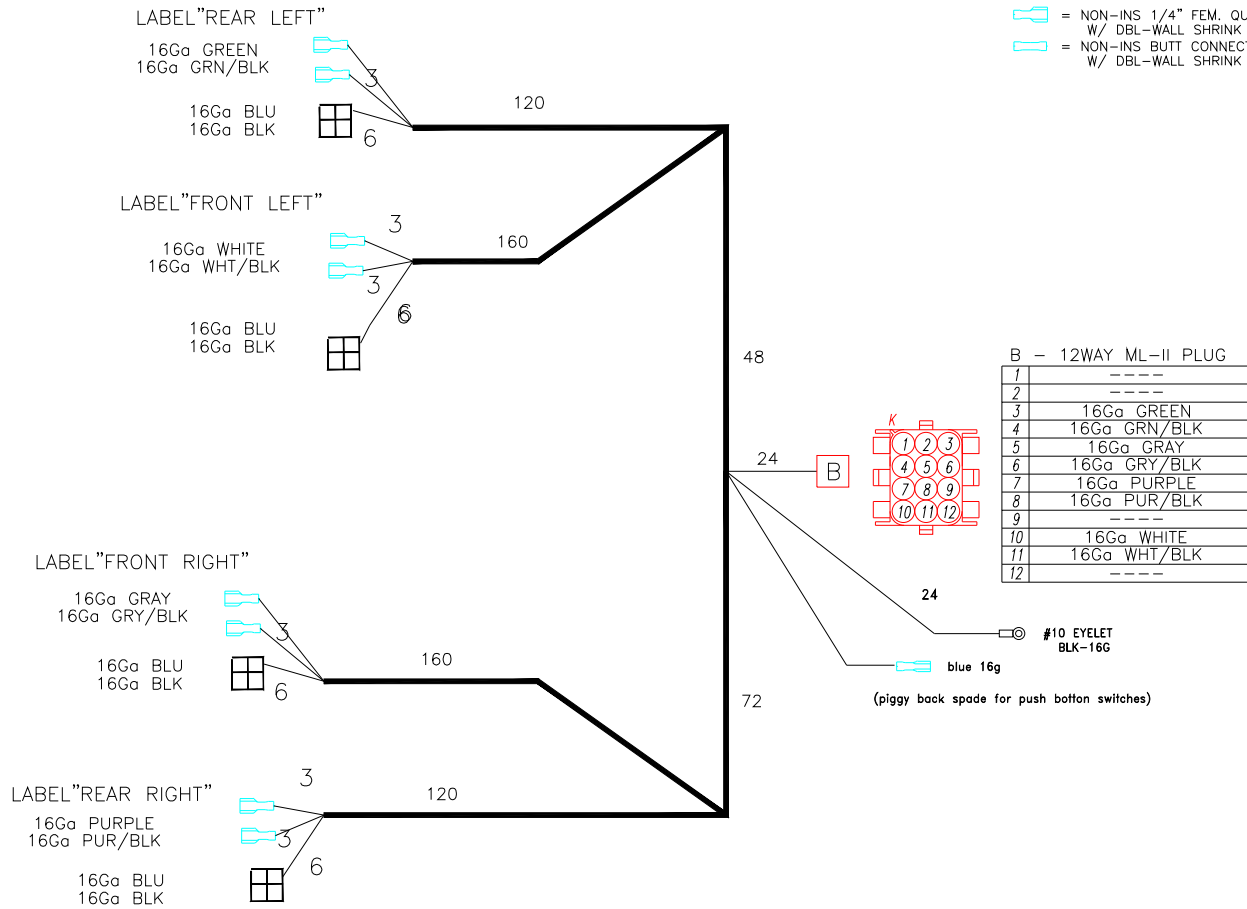

PANEL SWITCH SHROUD (P/N 6858) – OPTIONAL

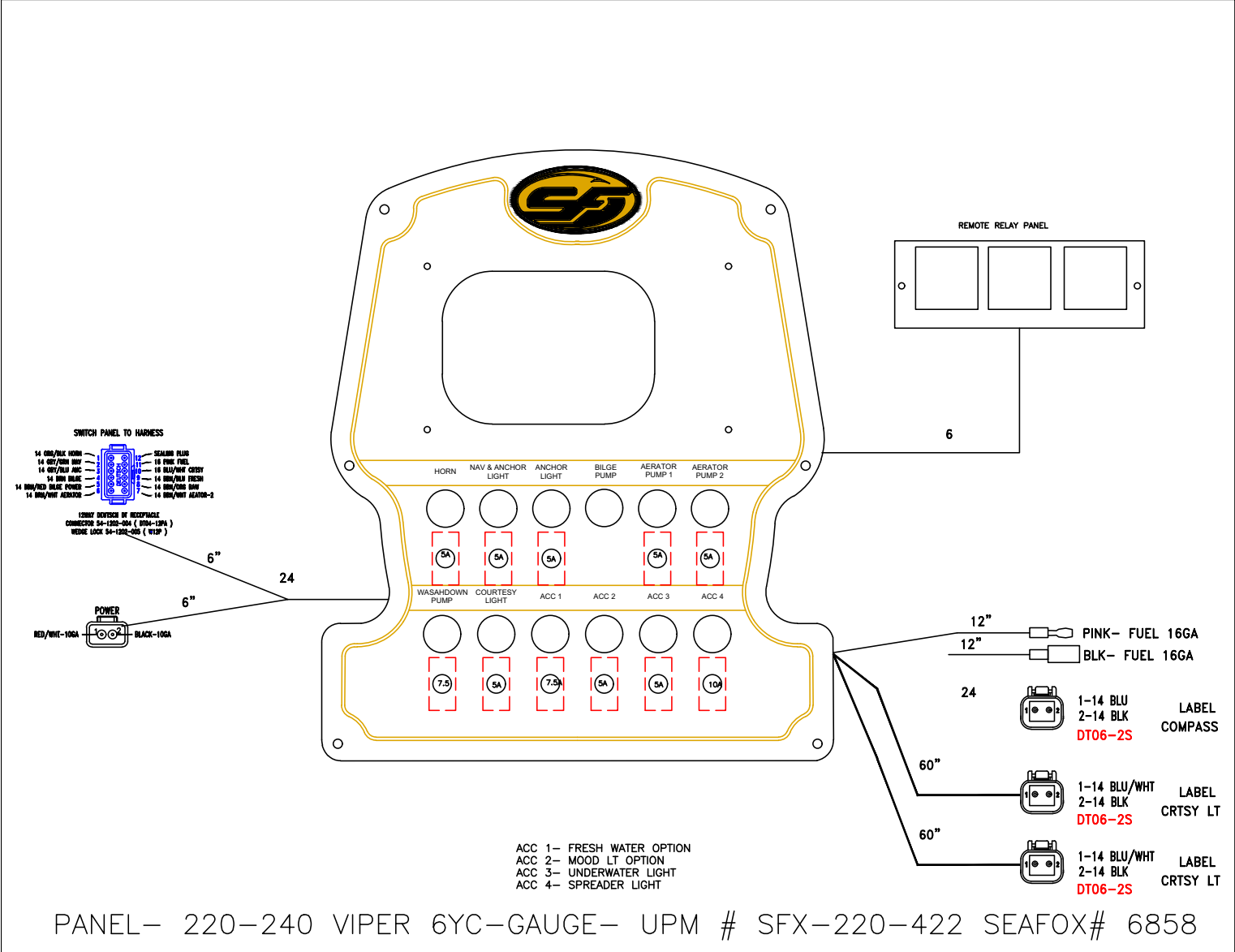

This Page Intentionally Left Blank

SEA FOX

BOAT WORKS

Sea Fox Boat Company, Inc.
2550 Highway 52
Moncks Corner, SC 29461-5024

Telephone: 843-761-6090
www.seafoxboats.com

Ken Cook Co.
Printed in U.S.A.
Rev 0224