

248C



Owner's Manual Supplement

www.seafoxboats.com

SEA FOX BOAT'S DISCLAIMER

The following Owner's Manual is provided for information and educational purposes only and is not intended to offer or provide legal advice or create a contractual relationship between Sea Fox Boat Company and the owner of any Sea Fox brand vessel. Please beware that as a vessel owner you have non-delegable responsibilities regarding the safety, maintenance, fitness, and operation of your vessel and the extent of such responsibilities is ultimately determined by Federal law and regulations, the general maritime law of the United States, the laws and regulations of the states and territories of the United States, or the laws and regulations of the country where you operate your vessel. To fully understand your responsibilities as a vessel owner, and before operating or letting any third party operate your vessel, we recommend that you consult the services of a qualified lawyer in admiralty and maritime law.

TABLE OF CONTENTS

Introduction	3	Harness Nav Short	18
Specifications	3	Harness Kicker Only 6-Speaker	19
Designated Occupant Seating	4	Harness JL 6-Speaker	20
Safety Decals.	5	JL Audio Breaker Kit Short	21
Plumbing Schematics	7	Trimtabs Electrical Switch Standard (P/N 2895) – Optional	22
Commander Bilge System.	7	Harness Mood Light w/Deutsch (P/N 6128) – Optional	23
Commander Drains	8	Harness Stereo Infinity Con (P/N 6129) – Optional.	24
Commander Drains (continued).	9	Harness Stereo Infinity Deck (P/N 6130) – Optional.	25
Commander Electric Head System	10	Harness Underwater Light w/Deutsch (P/N 6133) – Optional	26
Commander Fresh Water System	11	Harness Windlass Deck (P/N 6135) – Optional.	27
Commander Fuel System	12	Head Panel Switch ORB (P/N 6136) – Optional	28
Commander Livewell System	13	Harness Stereo Kicker Con 2016 (P/N 6851) – Optional	29
Commander Electric Head with Overboard Discharge System	14	Harness Stereo Kicker Deck 2016 (P/N 6852) – Optional	30
Commander Pod Livewell System	15	Head Panel Switch ORB (P/N 6870) – Optional	31
Commander Fresh Water System	16	Head Harness ORB (P/N 6874) – Optional	32
Electrical Schematics	17	U Panel Switch/Harness Ultima (P/N 7277) – Optional	33
Typical 2-Battery Setup in Console.	17		

This Page Intentionally Left Blank

INTRODUCTION

Congratulations and Welcome Aboard! With so many boat brands to choose from, we want to congratulate you on your decision to choose Sea Fox Boats. For more than 24 years, Sea Fox offers the finest hand-crafted saltwater boats carefully balanced with the build-quality, features, styling and performance for the fairest price. Our passion for boating is evident in every model we make and we appreciate that you've noticed the Sea Fox difference.

We share your love for the moments spent on the water with friends and family, which is why every Sea Fox boat offers a unique blend of fishing/family options, technologies and innovative features. Your choice of a Sea Fox affirms that you have performed your research and compared the value of your model with the competition.

Whether you are new to the boating lifestyle or an old salt, we ask that **you and all other operators** read the owner's manual, this supplement, and all other literature provided with the boat **before** operating the boat or any equipment. We also recommend that all operators enroll in a boating safety course available online - see References and Contact Information in this section for education resources online.

This supplement contains model-specific information not included with the owner's manual. This manual is not intended to be a replacement for specific product literature provided by engine, accessory or other major equipment manufacturers, but rather to supplement that information.

Because of our philosophy of continuous product improvement, this manual serves as a general guide only, so the specifications and illustrations used may not match the equipment on your boat and are intended only as general reference views.

We welcome you to the Sea Fox family and wish you many years of boating enjoyment!

SPECIFICATIONS

Max. Weight Capacity	2500 lbs (1134 kg)
Persons	10
Persons Weight	1500 lbs (680 kg)
Max. HP	300 hp (224 kw)
L.O. A.	24' 4" (7.41 m)
Beam	8' 6" (2.59 m)
Draft	14 in. (0.36 m)
Height, Keel to Top (Light Folded)	115 in. (2.92 m)
Bridge Clearance Hard Top	99 in. (2.51 m)
Max. Weight Boat (w/ Fluids, Largest HP)	5260 lbs (2386 kg)
Fuel Tank Capacity	117 gal (443 L)
Freshwater Tank Capacity	12 gal (45 L)
Holding Tank Capacity	12 gal (45 L)

DESIGNATED OCCUPANT SEATING

Be sure all passengers are properly seated in designated seating positions and not riding on the bow, bow pulpit, deck, gunwale or rear sun deck while underway. Passengers must use hand-holds and use caution when riding in the bow. Move to the aft passenger seats during rough water operation or if visibility is restricted.

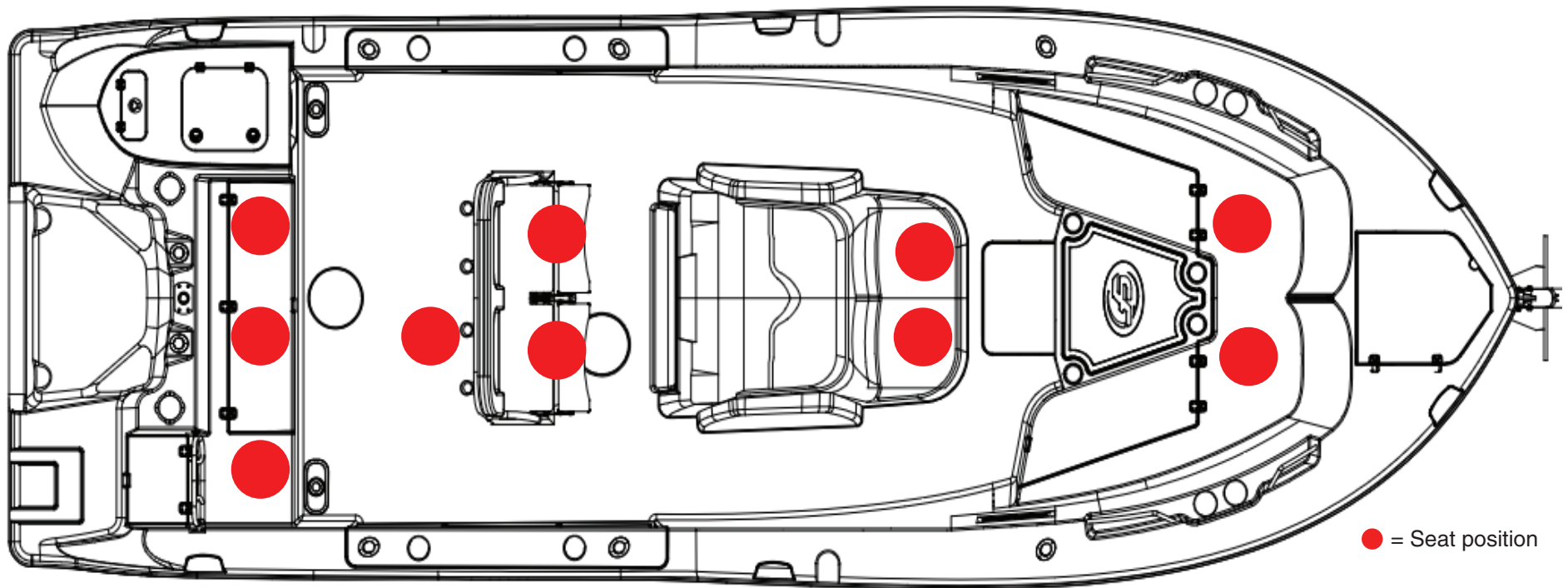

SFOX-0011

SAFETY DECALS



8



8

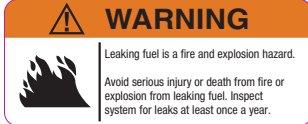

6



8



3

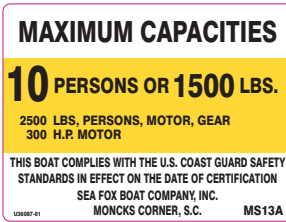

3

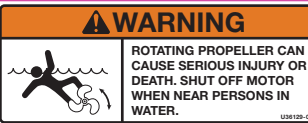

3

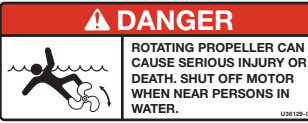

8

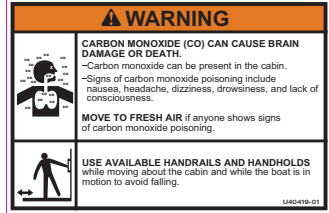

7

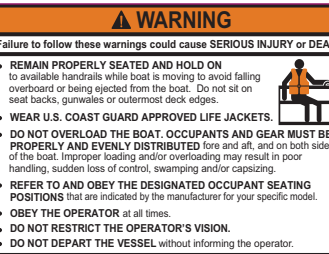

1



5

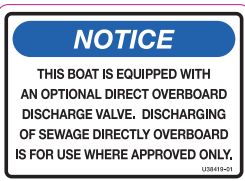

2

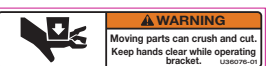

5

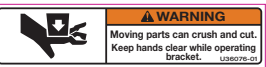

5

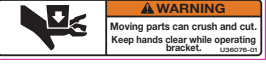

7

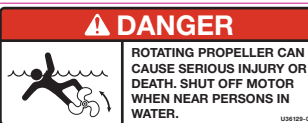

8



3



3



6



8

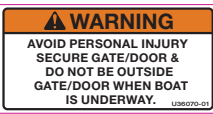

7



4



8

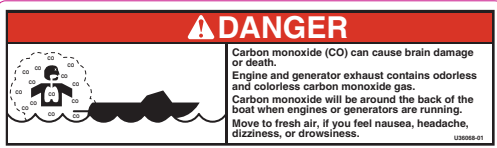

8



6



8

- 1= COCKPIT FRONT
- 2= HEAD COMPARTMENT
- 3= CONSOLE
- 4= FUEL FILL
- 5= COCKPIT MID SHIP
- 6= COCKPIT AFT
- 7= TRANSOM GATE
- 8= TRASOM

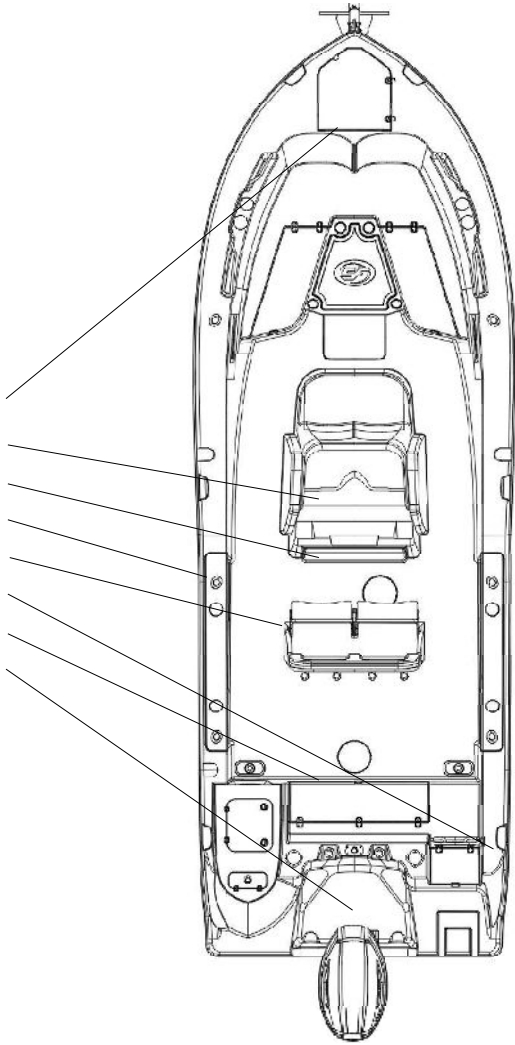

PLUMBING SCHEMATICS

COMMANDER BILGE SYSTEM

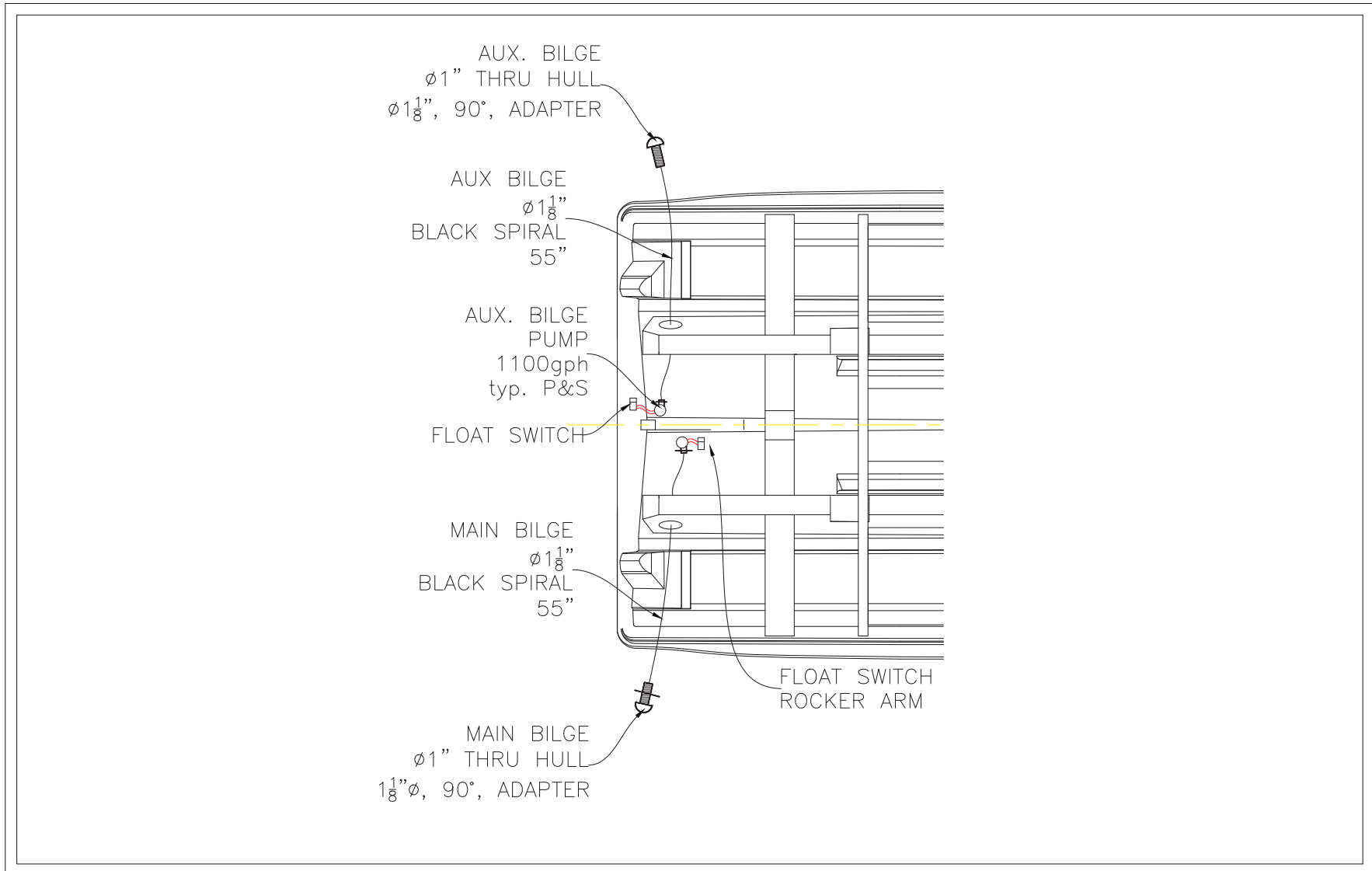

COMMANDER DRAINS

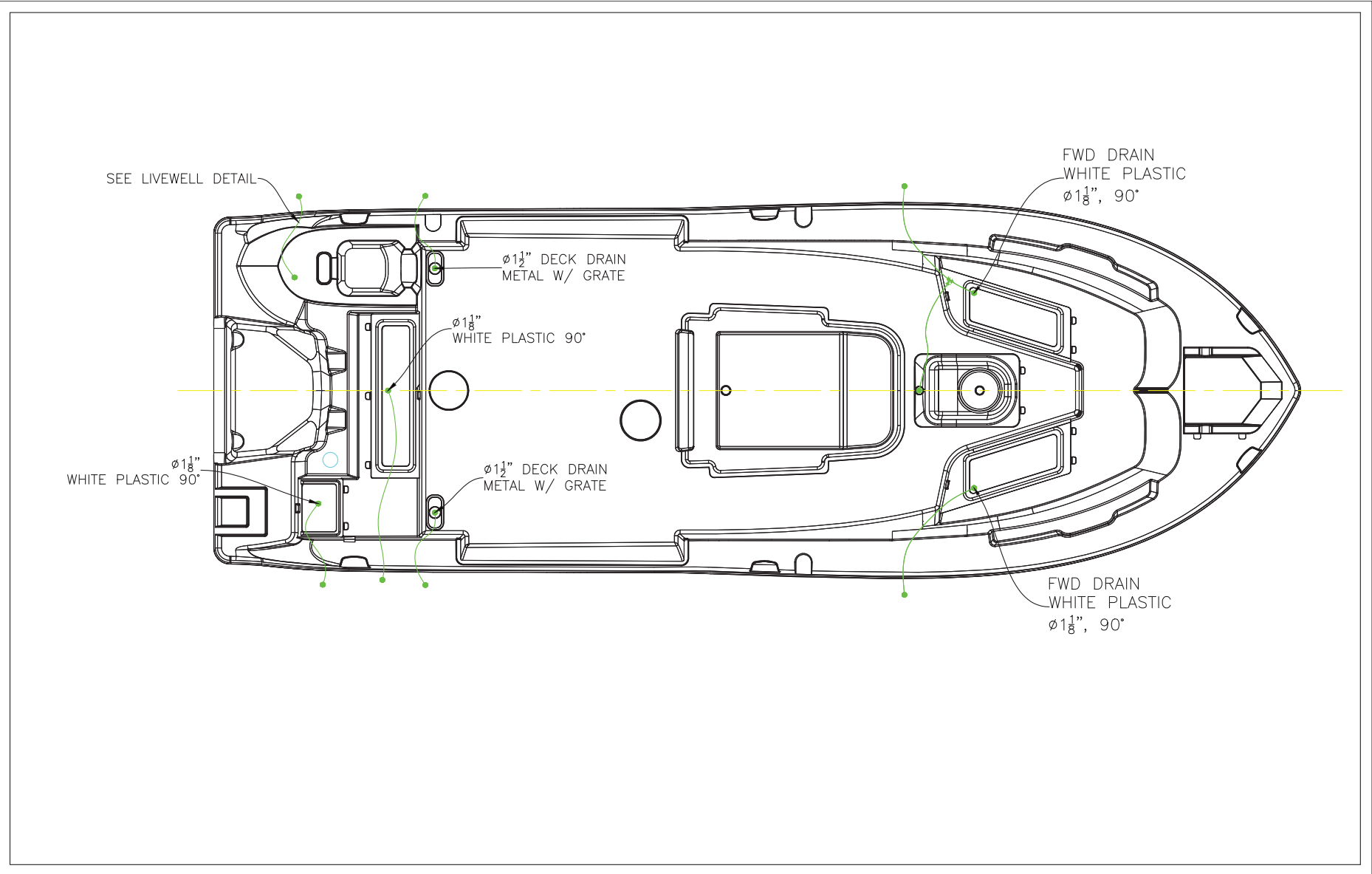

COMMANDER DRAINS (CONTINUED)

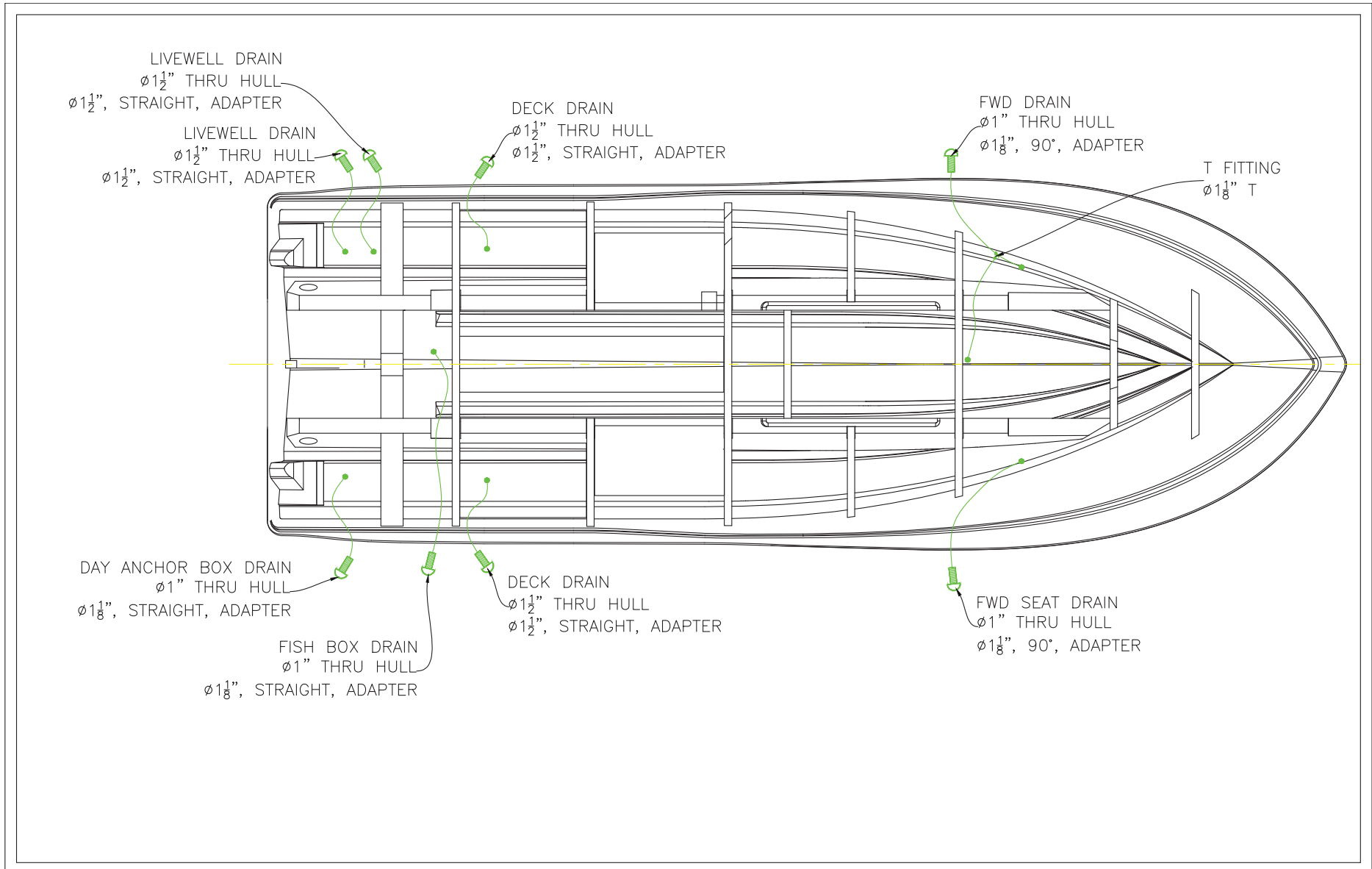

COMMANDER ELECTRIC HEAD SYSTEM

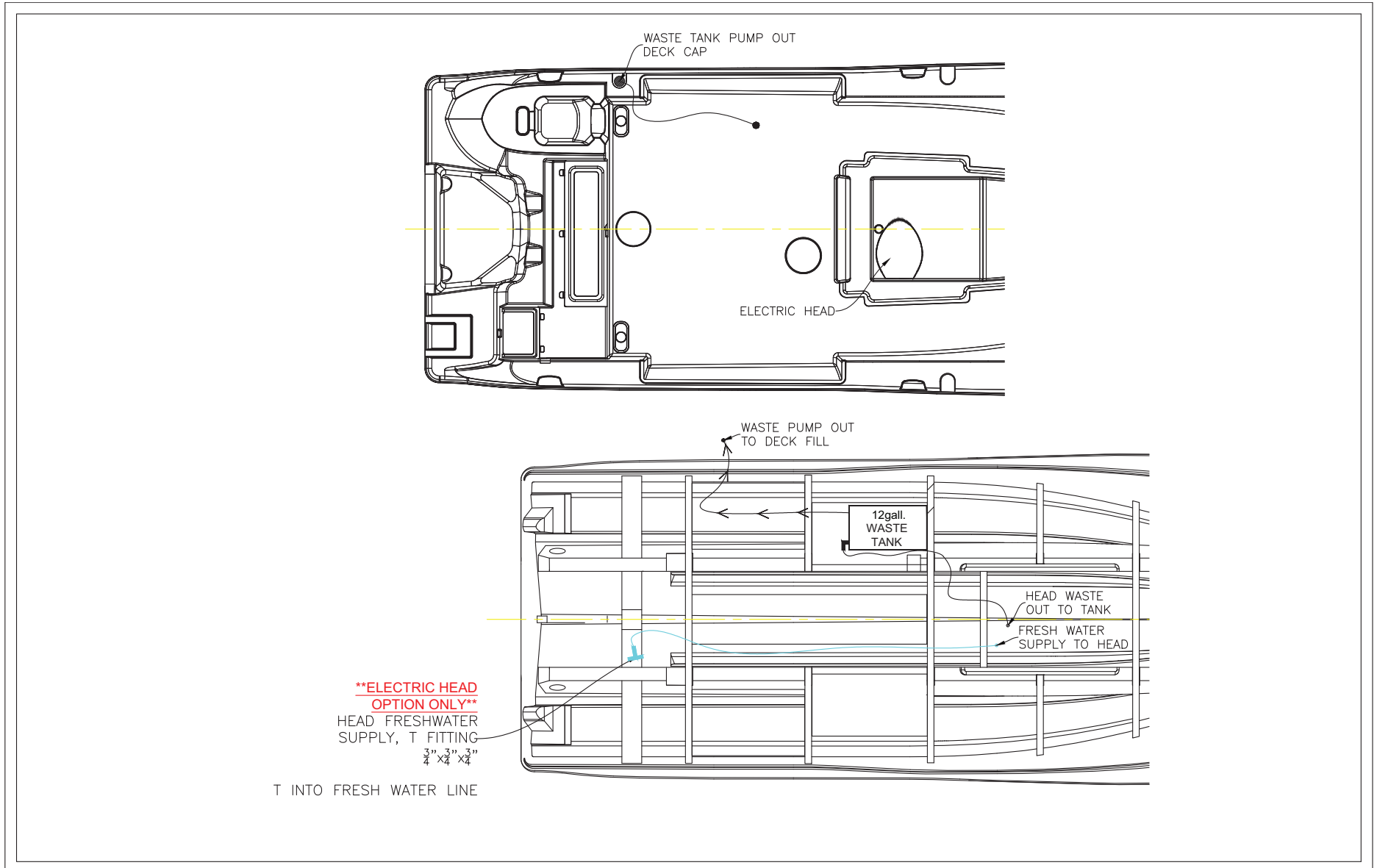

COMMANDER FRESH WATER SYSTEM

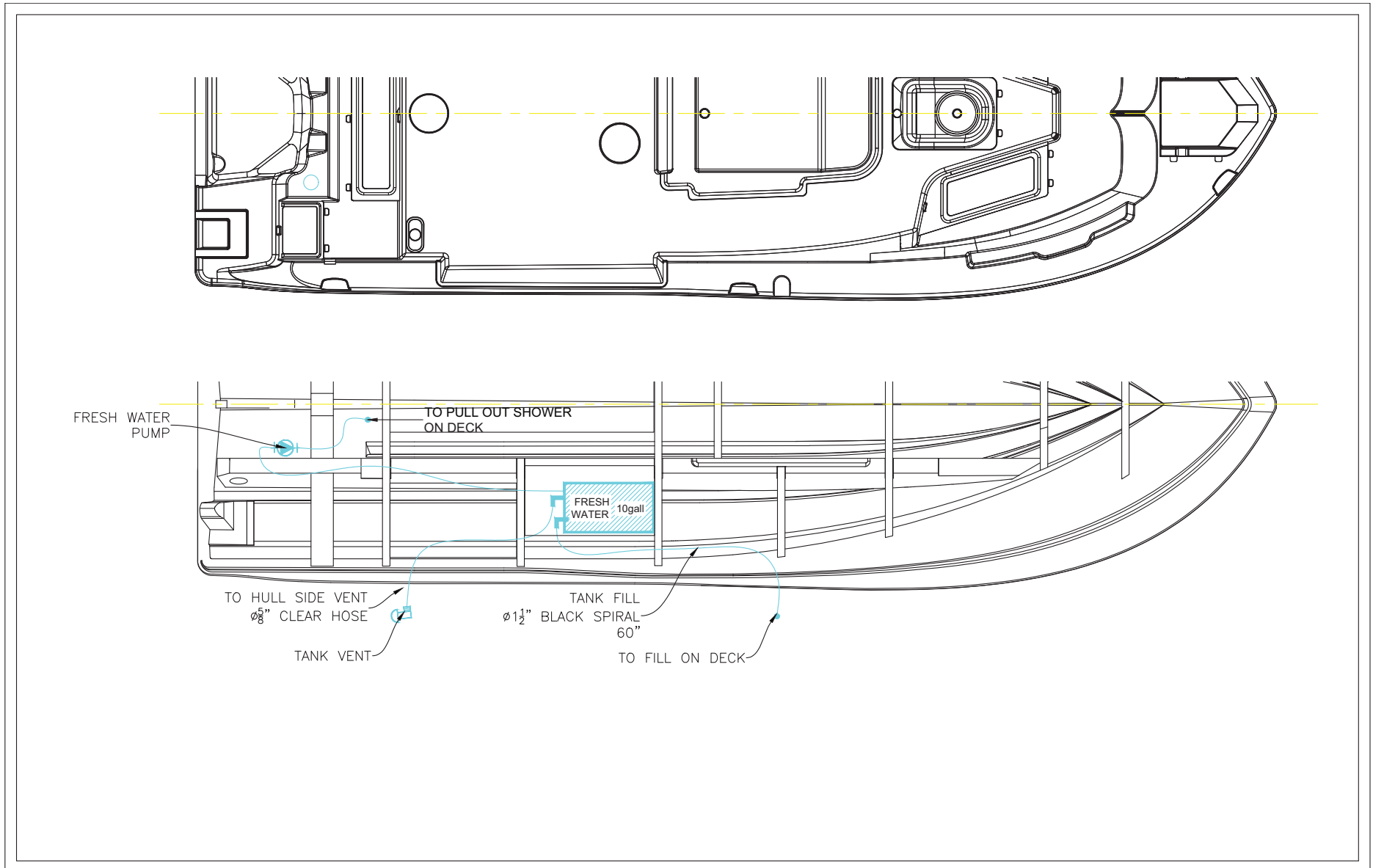

COMMANDER FUEL SYSTEM

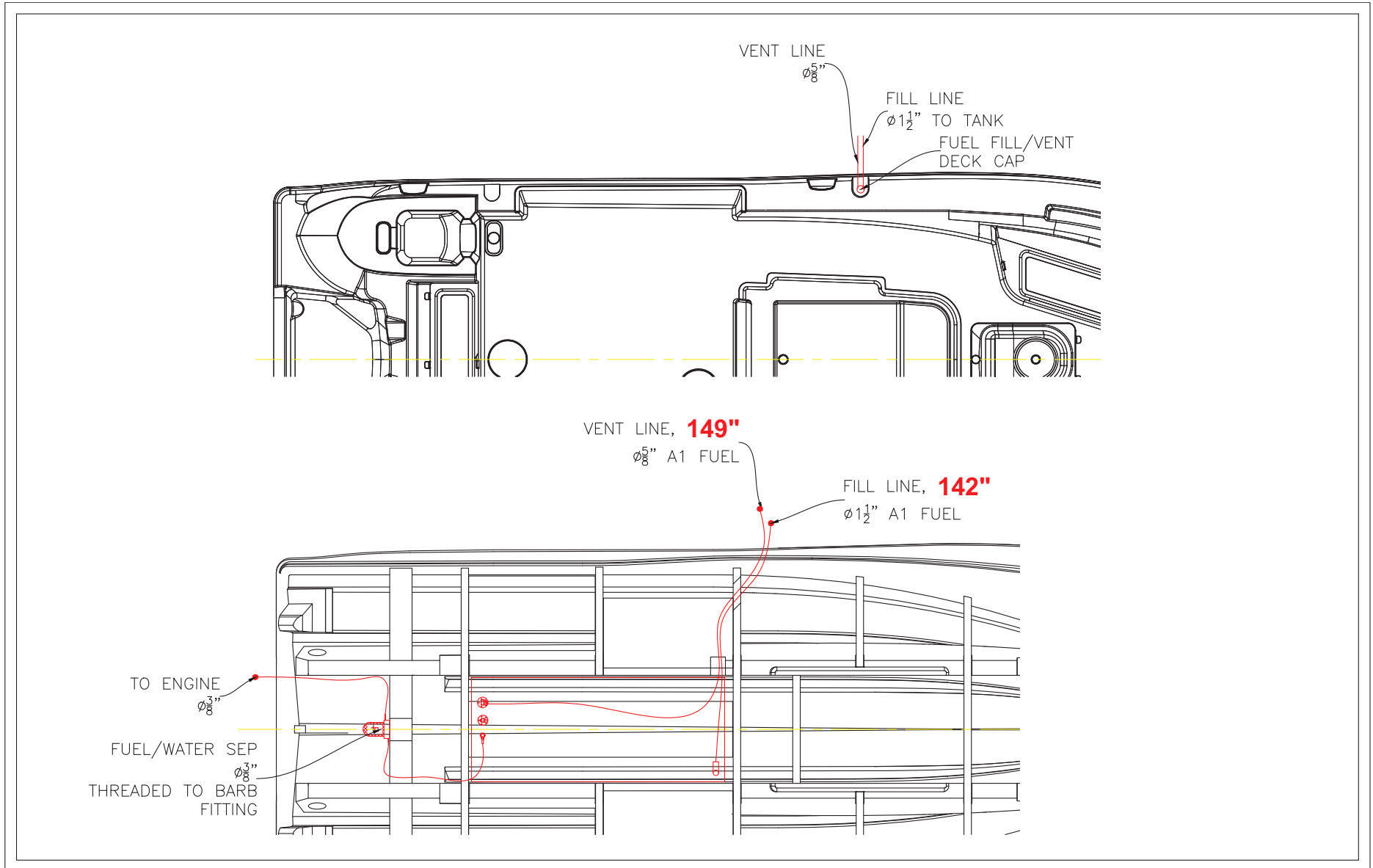

COMMANDER LIVEWELL SYSTEM

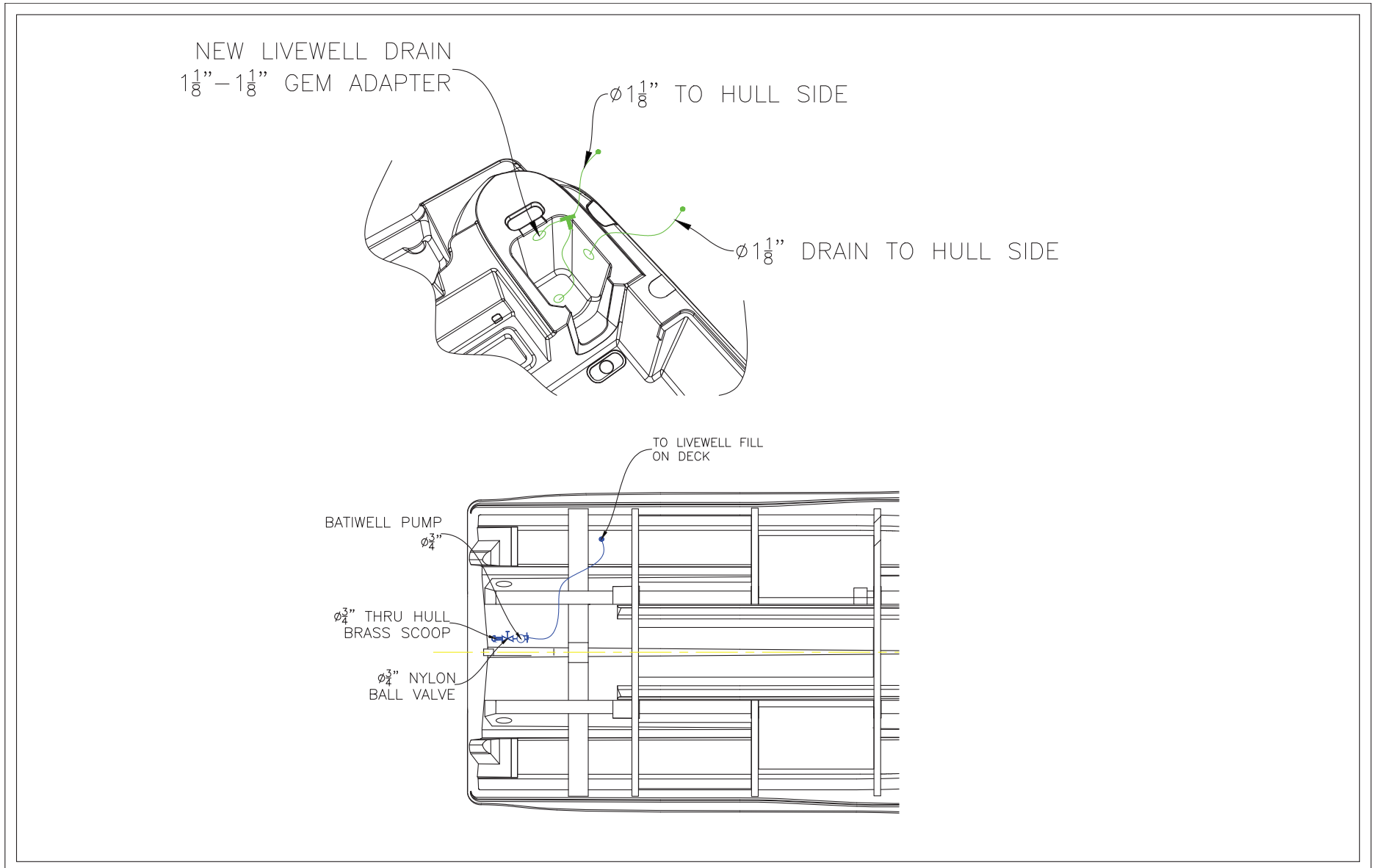

COMMANDER ELECTRIC HEAD WITH OVERBOARD DISCHARGE SYSTEM

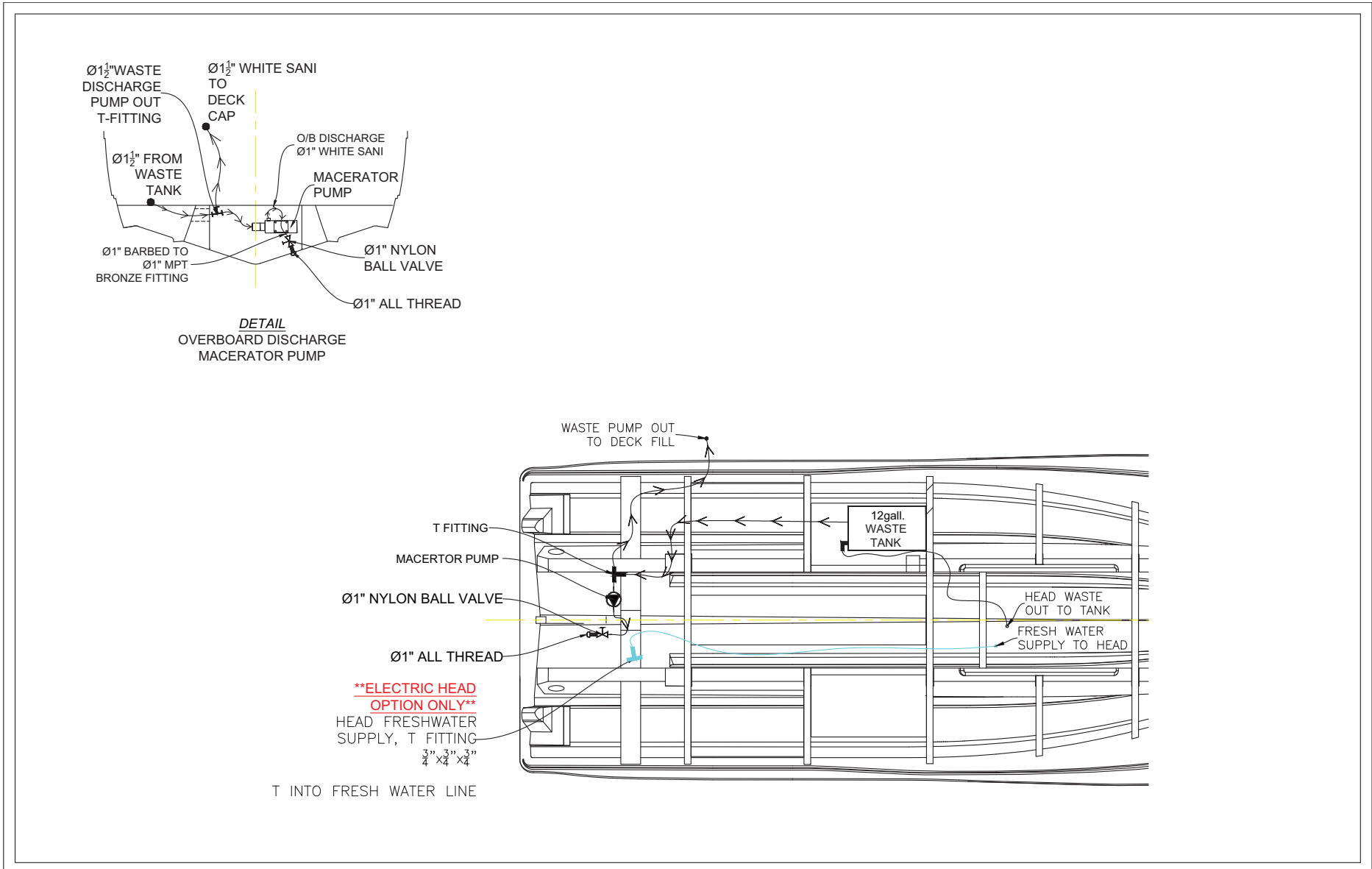

COMMANDER POD LIVEWELL SYSTEM

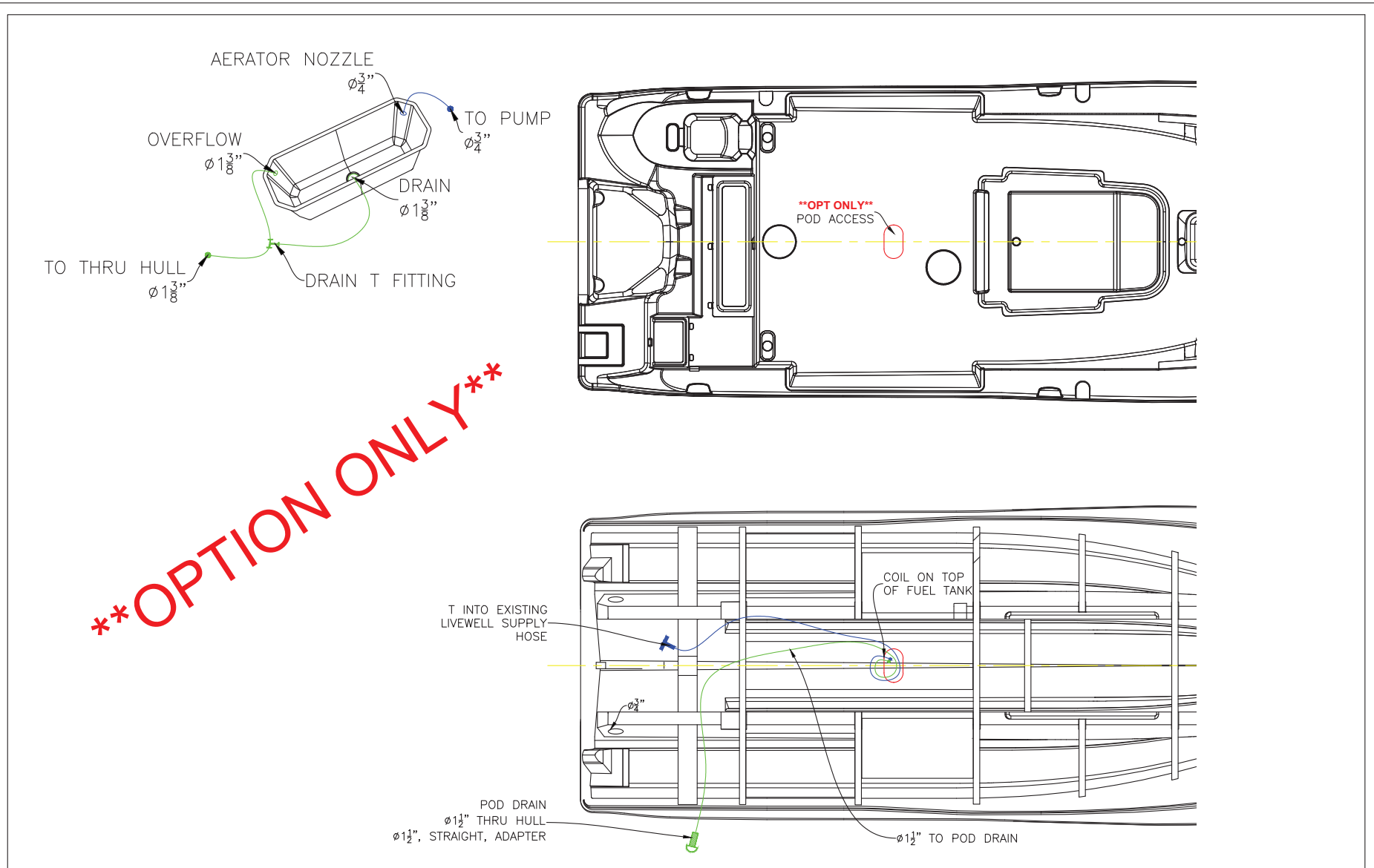

COMMANDER FRESH WATER SYSTEM

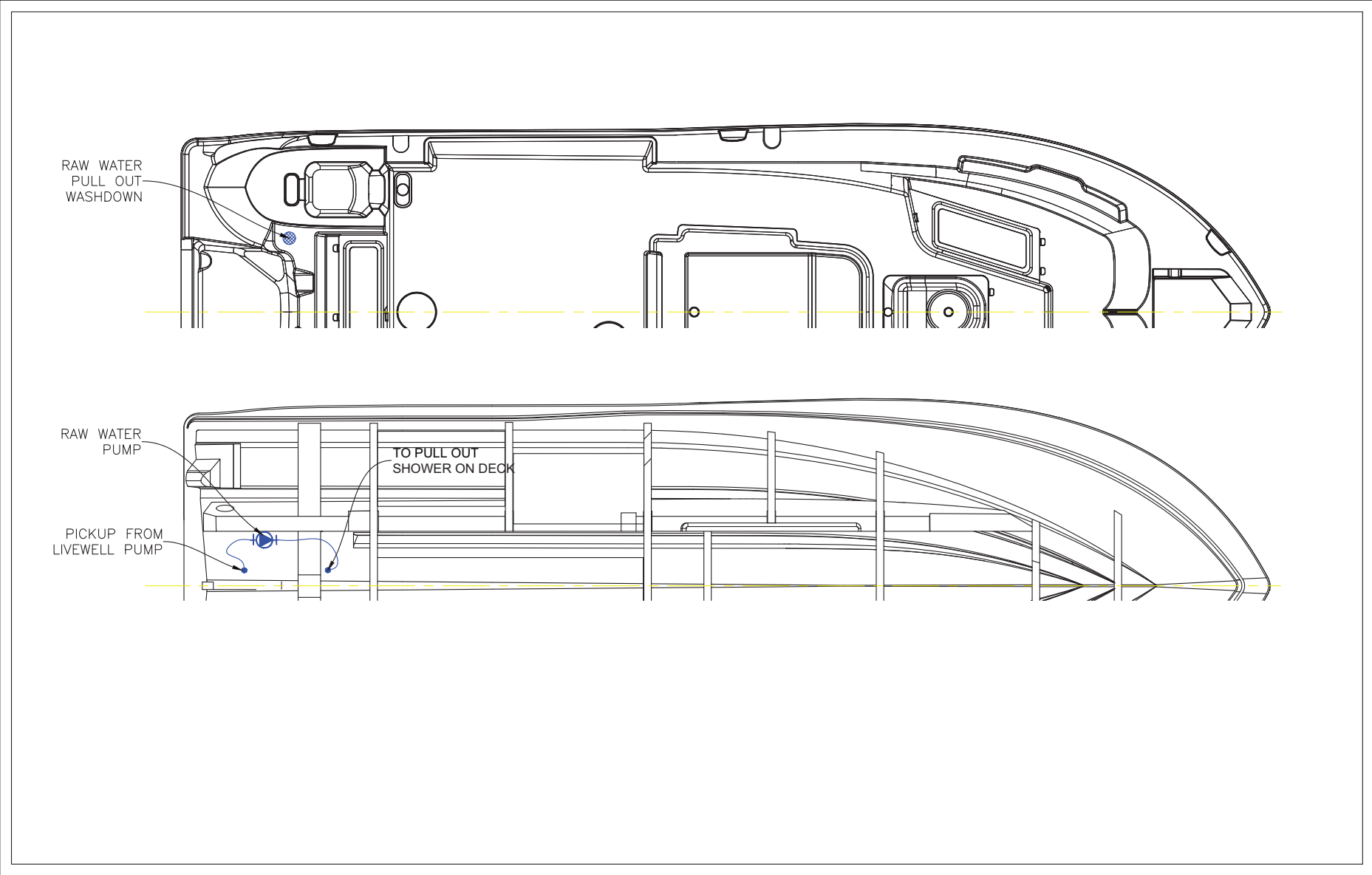

ELECTRICAL SCHEMATICS

TYPICAL 2-BATTERY SETUP IN CONSOLE

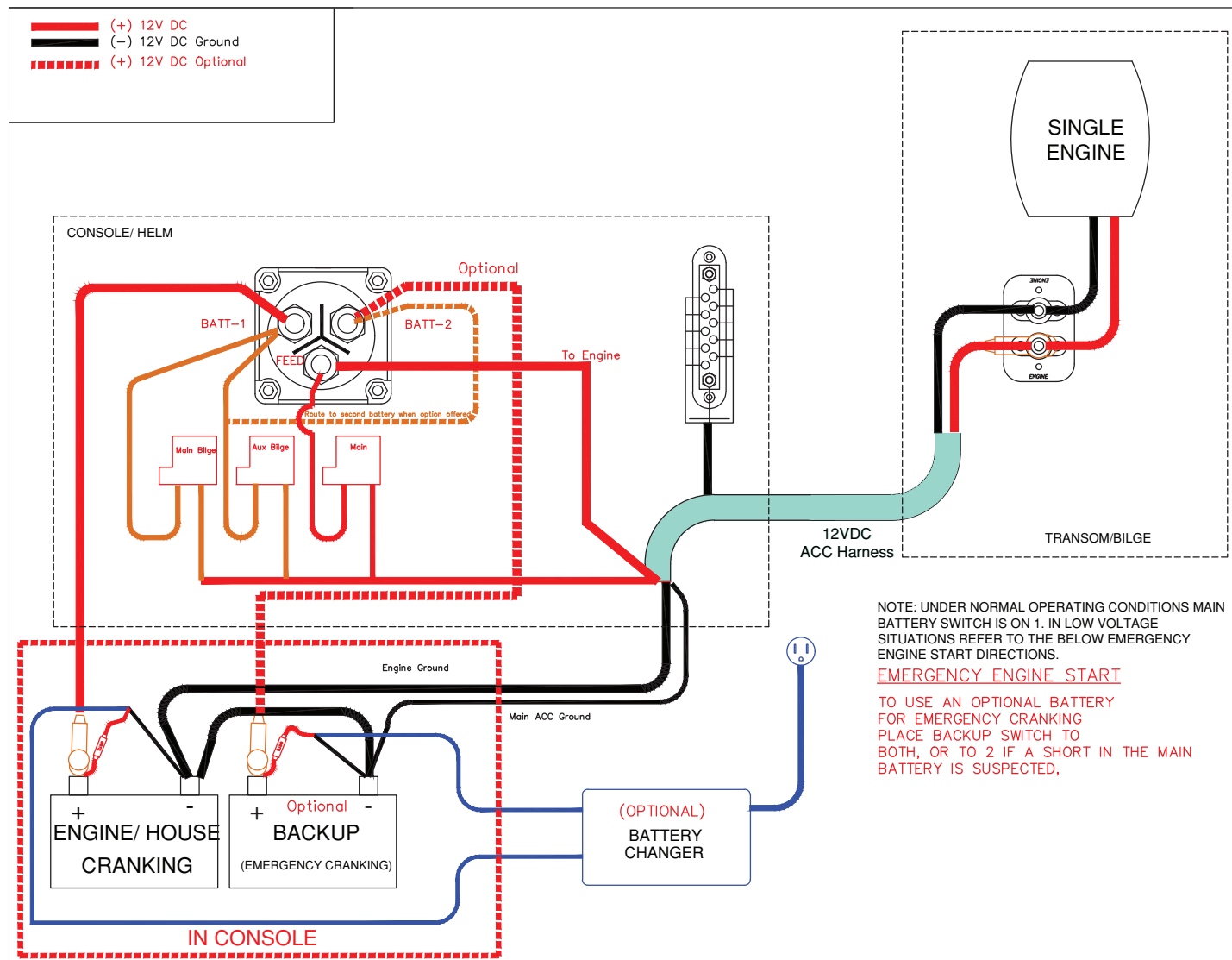

HARNES NAV SHORT

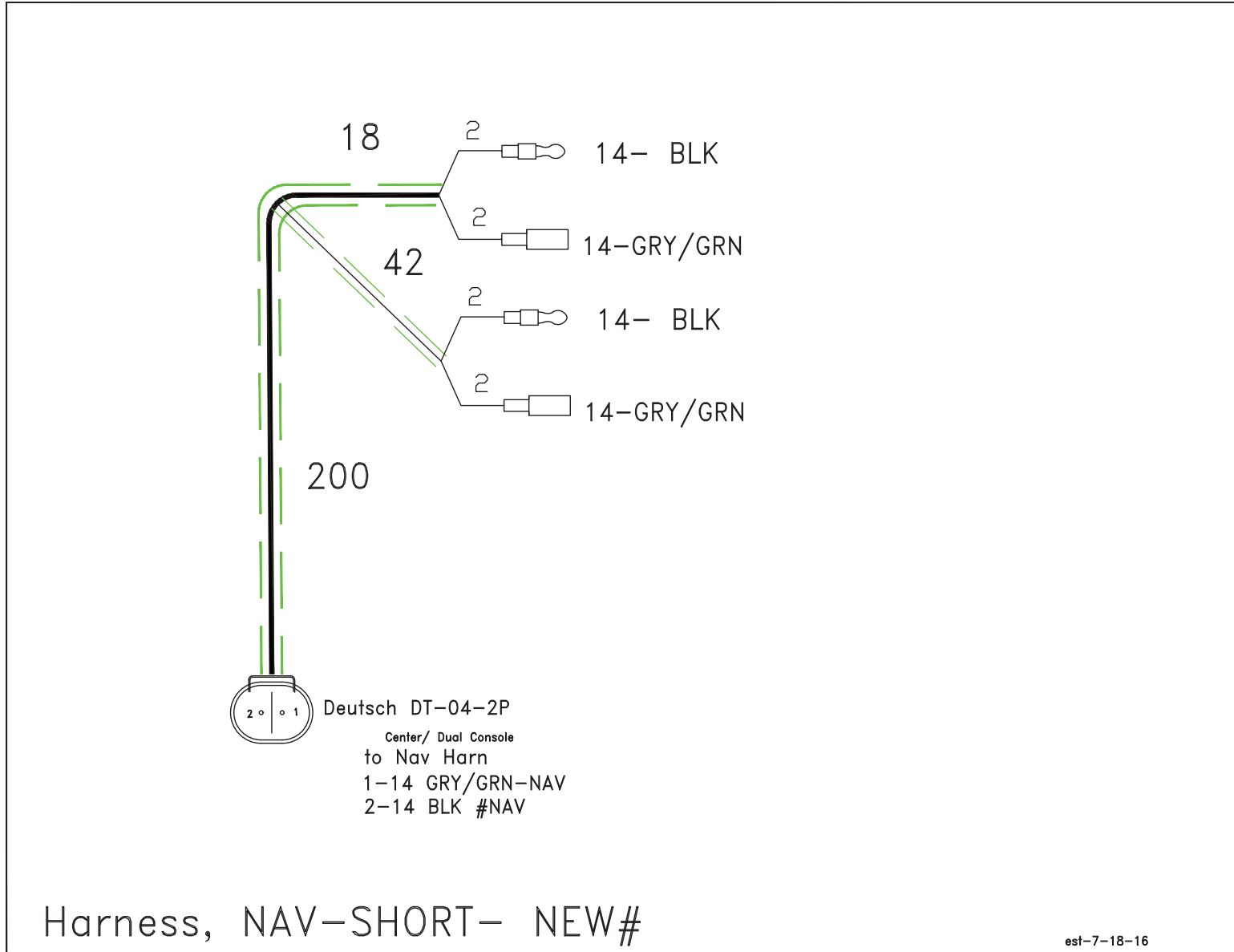

HARNES KICKER ONLY 6-SPEAKER

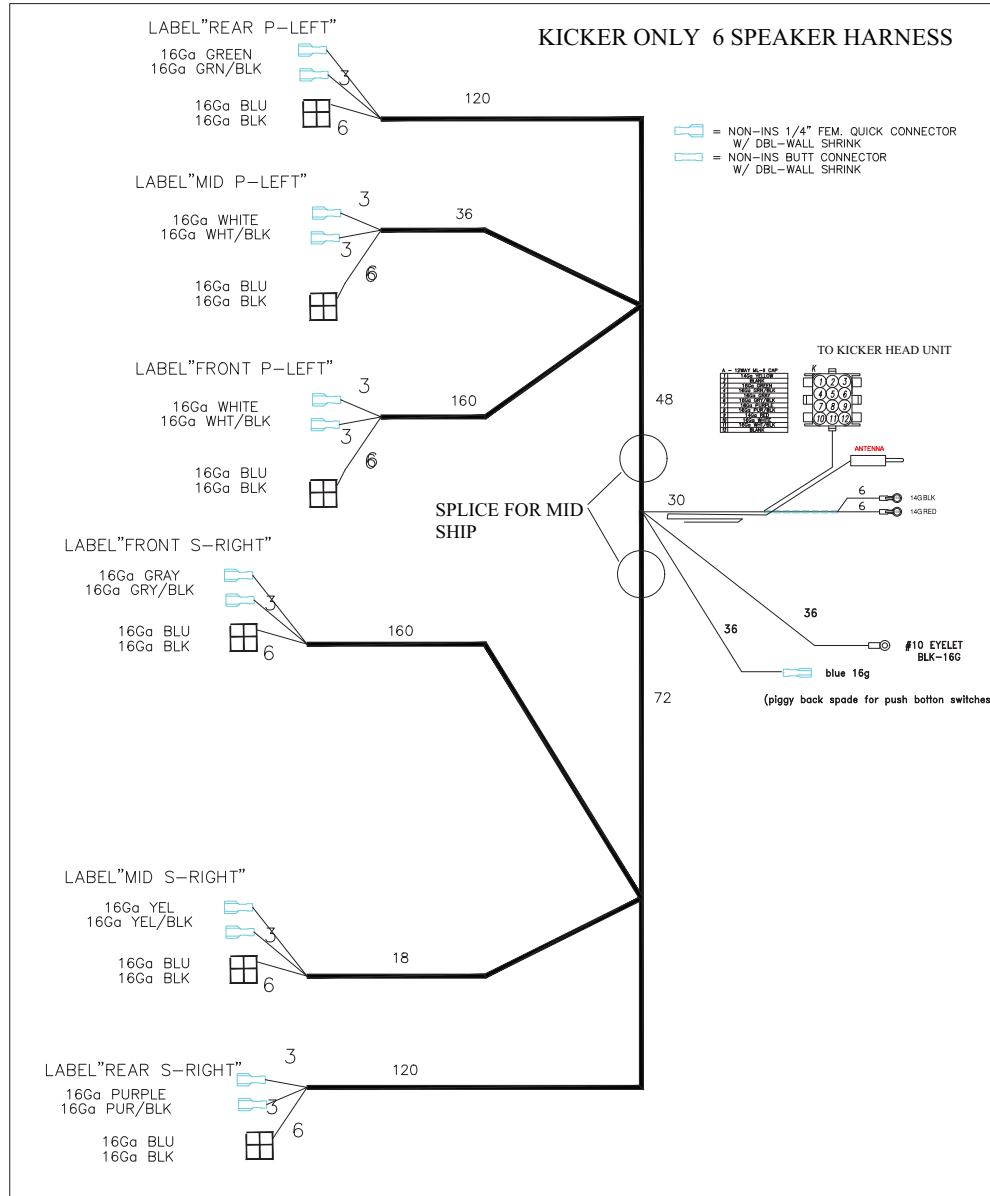

HARNESS JL 6-SPEAKER

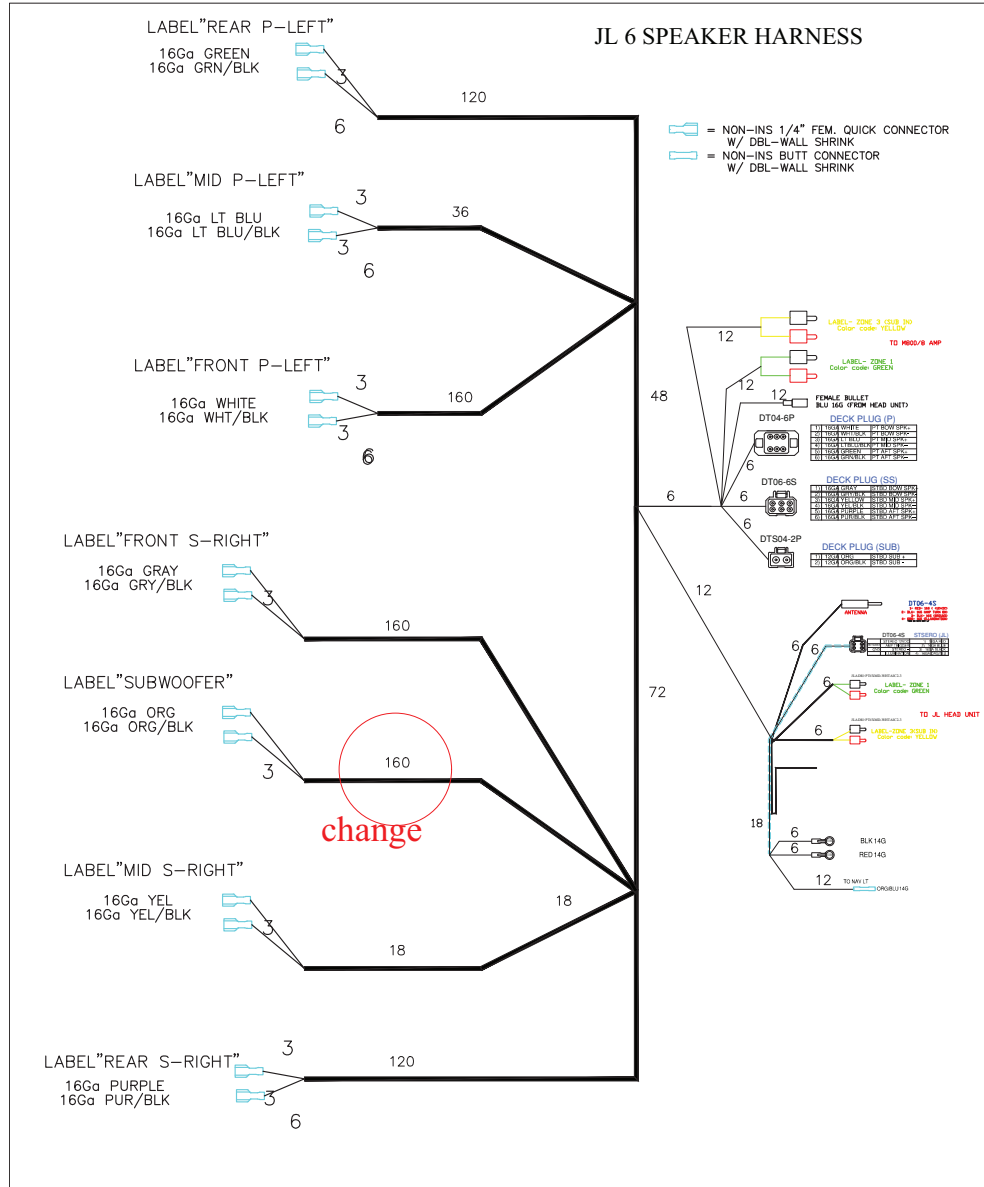

JL AUDIO BREAKER KIT SHORT

JL AUDIO BREAKER KIT SHORT 800/8

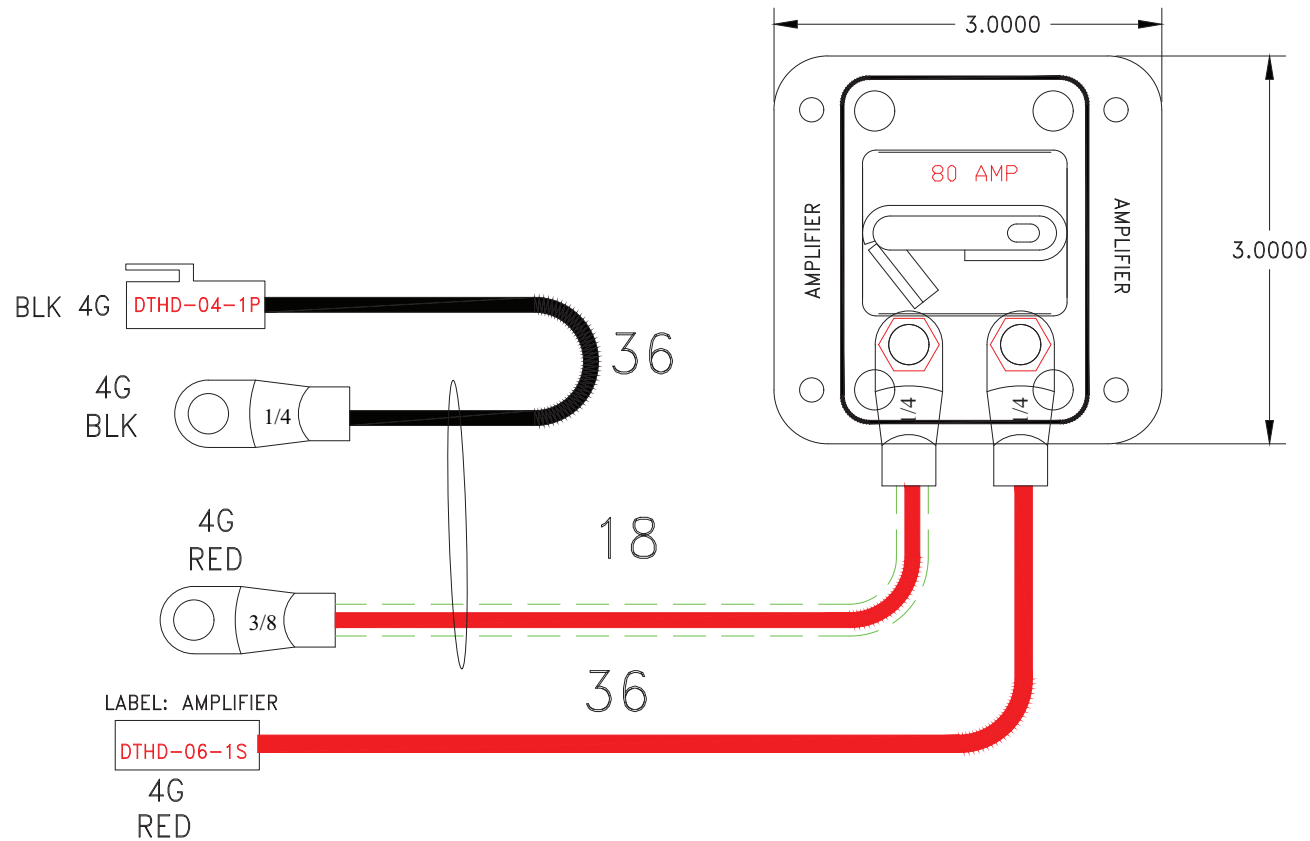

TRIMTABS ELECTRICAL SWITCH STANDARD (P/N 2895) – OPTIONAL

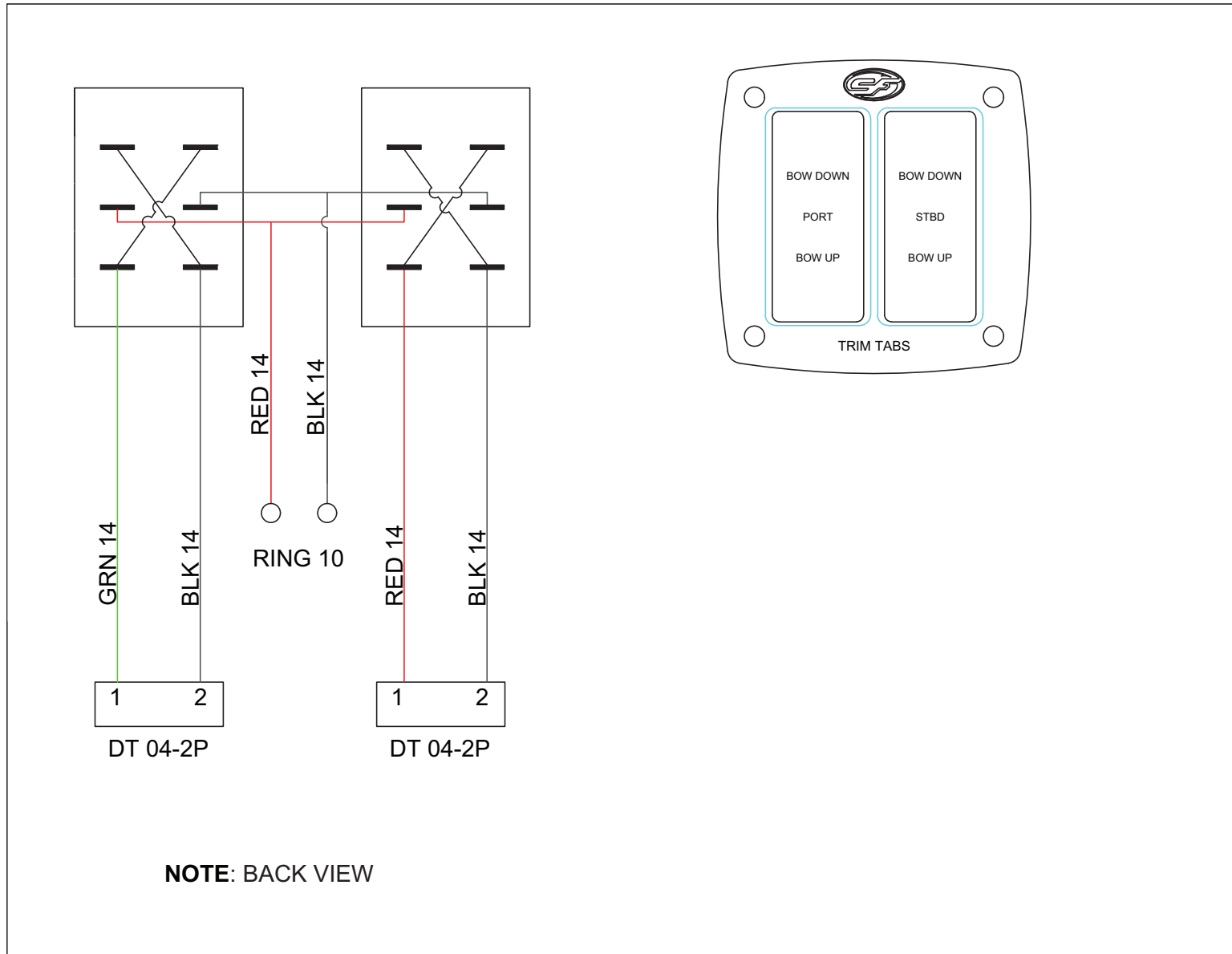

HARNES MOOD LIGHT W/DEUTSCH (P/N 6128) – OPTIONAL

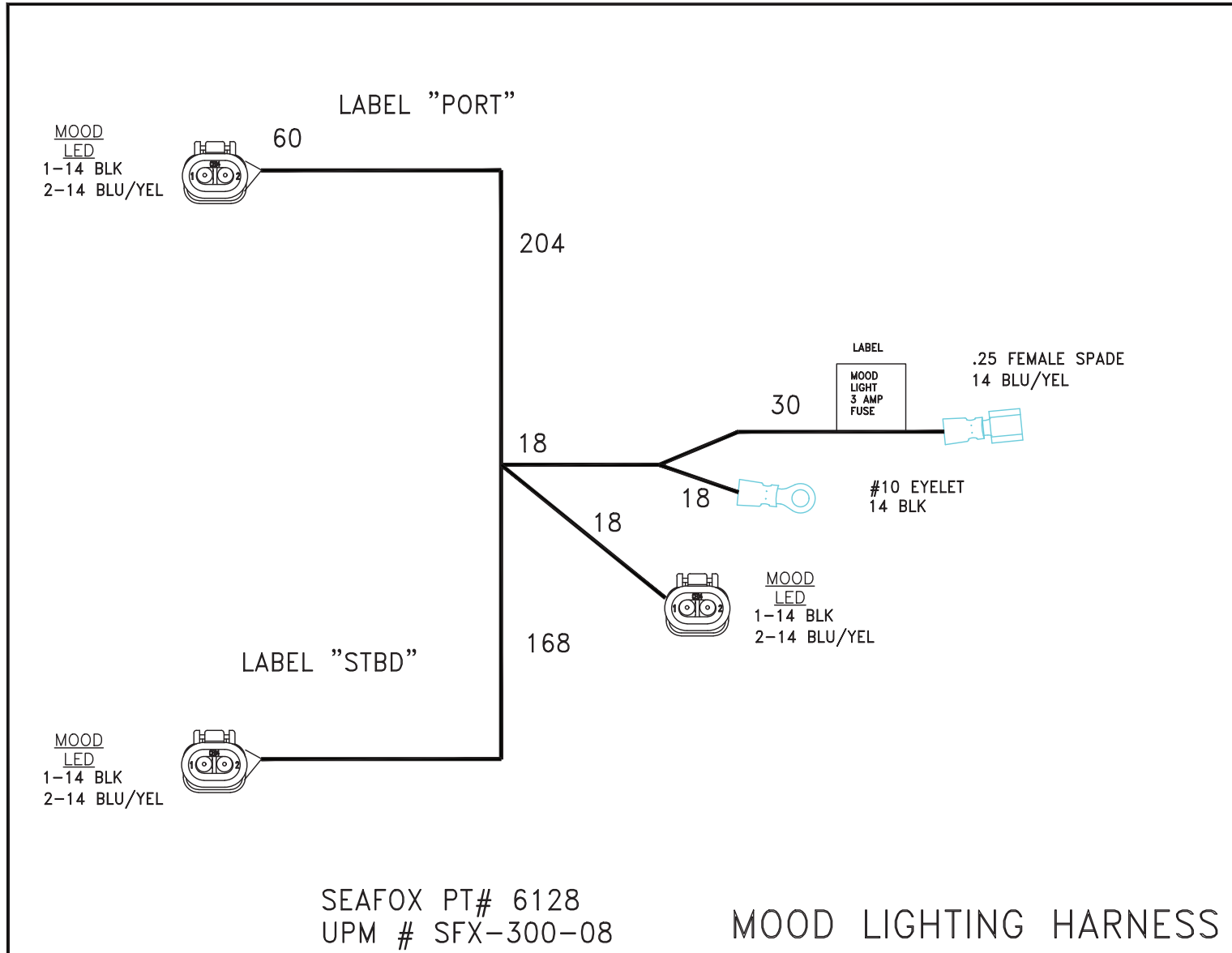

HARNES STEREO INFINITY CON (P/N 6129) – OPTIONAL

CUSTOMER SEAFOX BOAT CO. W/O # _____

PART # 6129 UPM# SFX-300-09 DUE DATE _____

MODEL ALL MODELS

FILENAME _____ DESCRIPTION HARNES STEREO INFINITY/JENSEN

NOTES:

- (1) SPLICE CONNECTION IS SOLDER DIPPED AND INSULATED WITH ADHESIVE-LINED HEAT-SHRINK
- (2) TERMINAL LEGEND:
- = ADHESIVE-LINED CRIMP CONNECTOR
 - = NON-INS 1/4" FEM. QUICK CONNECTOR W/ DBL-WALL SHRINK
 - = NON-INS 0.205" FEM. QUICK CONNECTOR W/ DBL-WALL SHRINK
 - = #8 SNAP SPADE W/ DBL-WALL SHRINK
 - = 0.156 NON-INS MALE W/ BLUE INSULATOR
 - = 0.156 NON-INS FEMALE W/ BLUE INSULATOR
 - = RING TERMINAL W/ ADHESIVE-LINED SHRINK OR SOLDER DIPPED AND ADHESIVE-LINED SHRUNK
- (3) " " = TAGGING TEXT

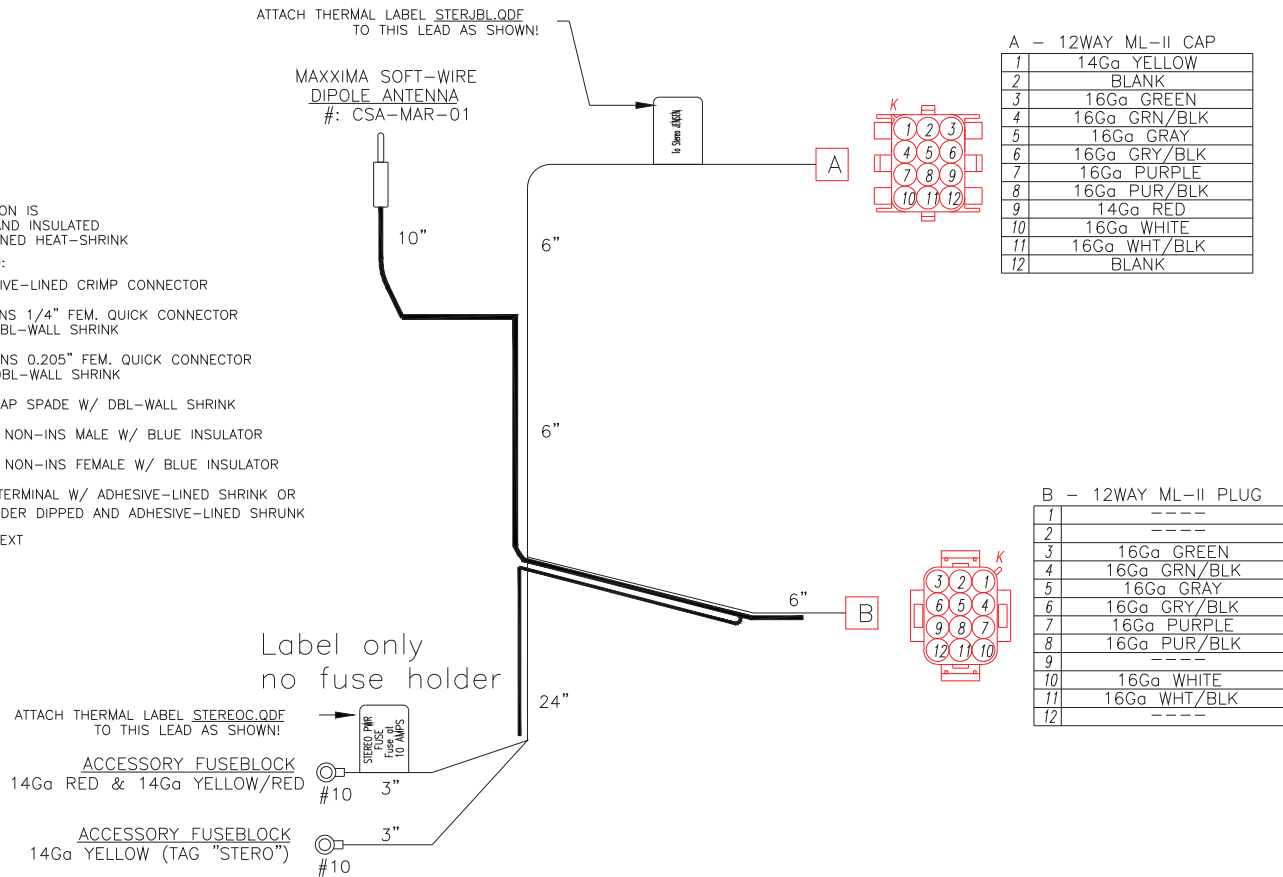

HARNES STEREO INFINITY DECK (P/N 6130) – OPTIONAL

CUSTOMER SEAFOX BOAT CO.
 PART # 6130 UPM# SFX-300-04
 FILENAME _____

W/O # _____
 DUE DATE _____
 MODEL ALL MODELS
 DESCRIPTION HARNES DECK ININTY STEREO

NOTES:

 = NON-INS 1/4" FEM. QUICK CONNECTOR
 W/ DBL-WALL SHRINK

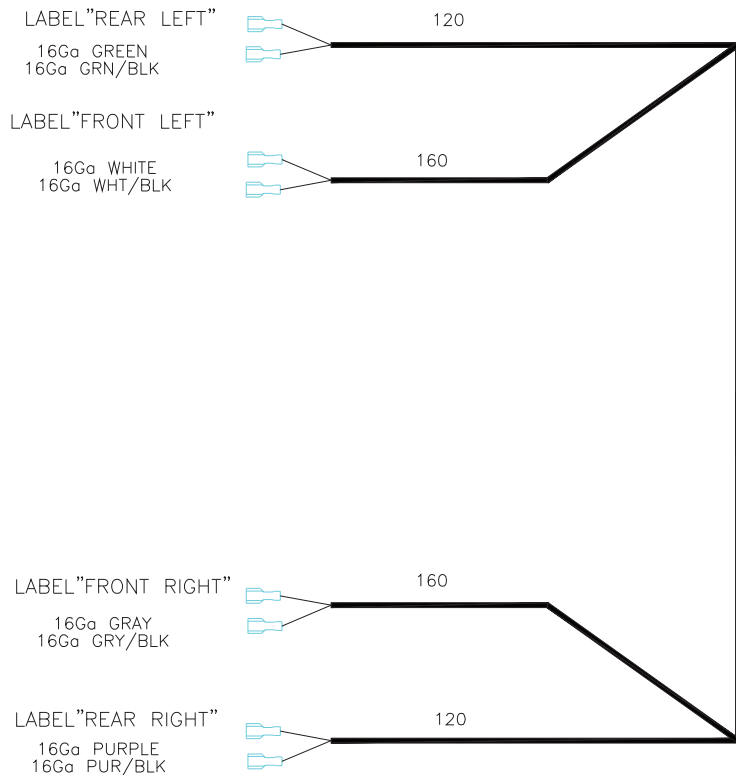

B - 12WAY ML-II PLUG

1	----
2	----
3	16G _a GREEN
4	16G _a GRN/BLK
5	16G _a GRAY
6	16G _a GRY/BLK
7	16G _a PURPLE
8	16G _a PUR/BLK
9	----
10	16G _a WHITE
11	16G _a WHT/BLK
12	----

HARNES UNDERWATER LIGHT W/DEUTSCH (P/N 6133) – OPTIONAL

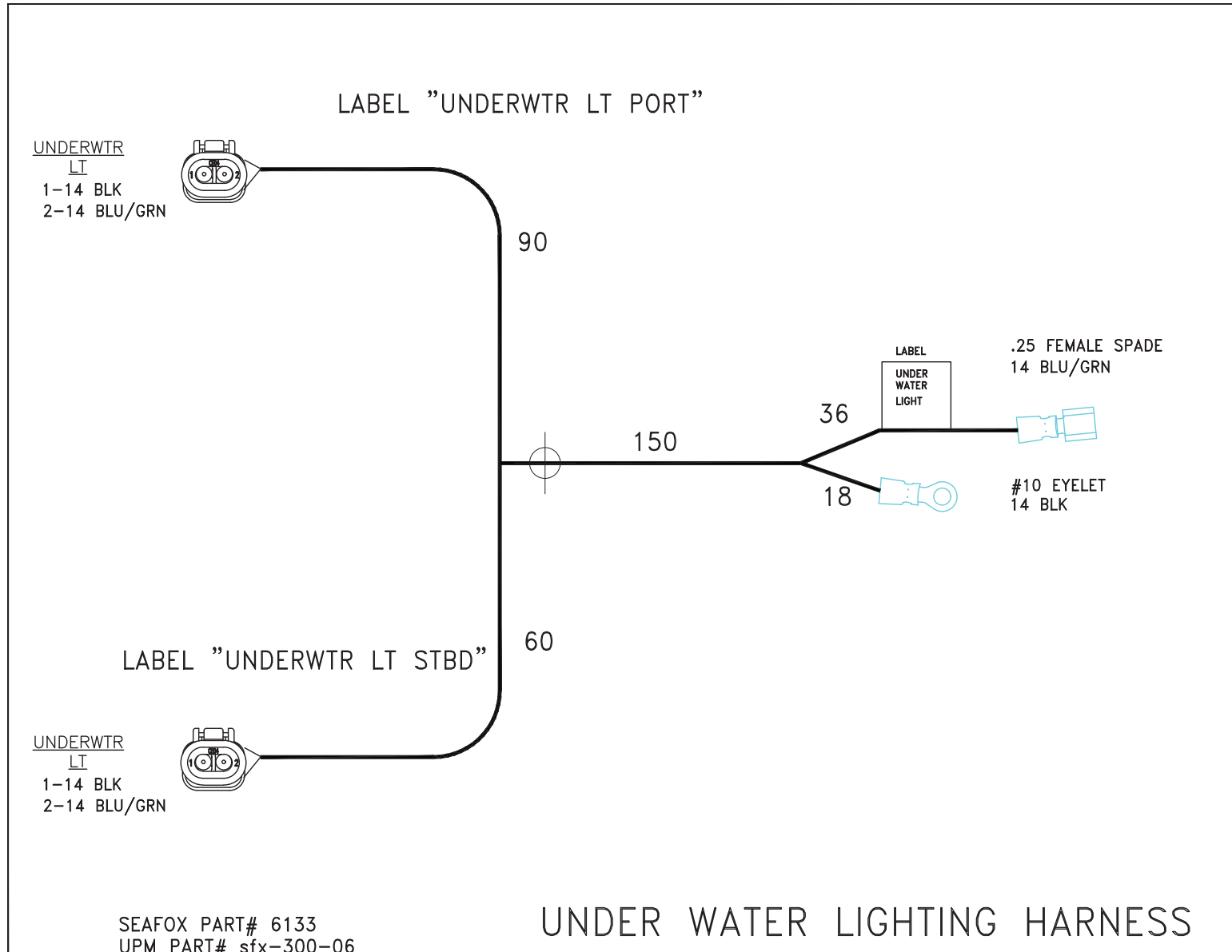

HARNES WINDLASS DECK (P/N 6135) – OPTIONAL

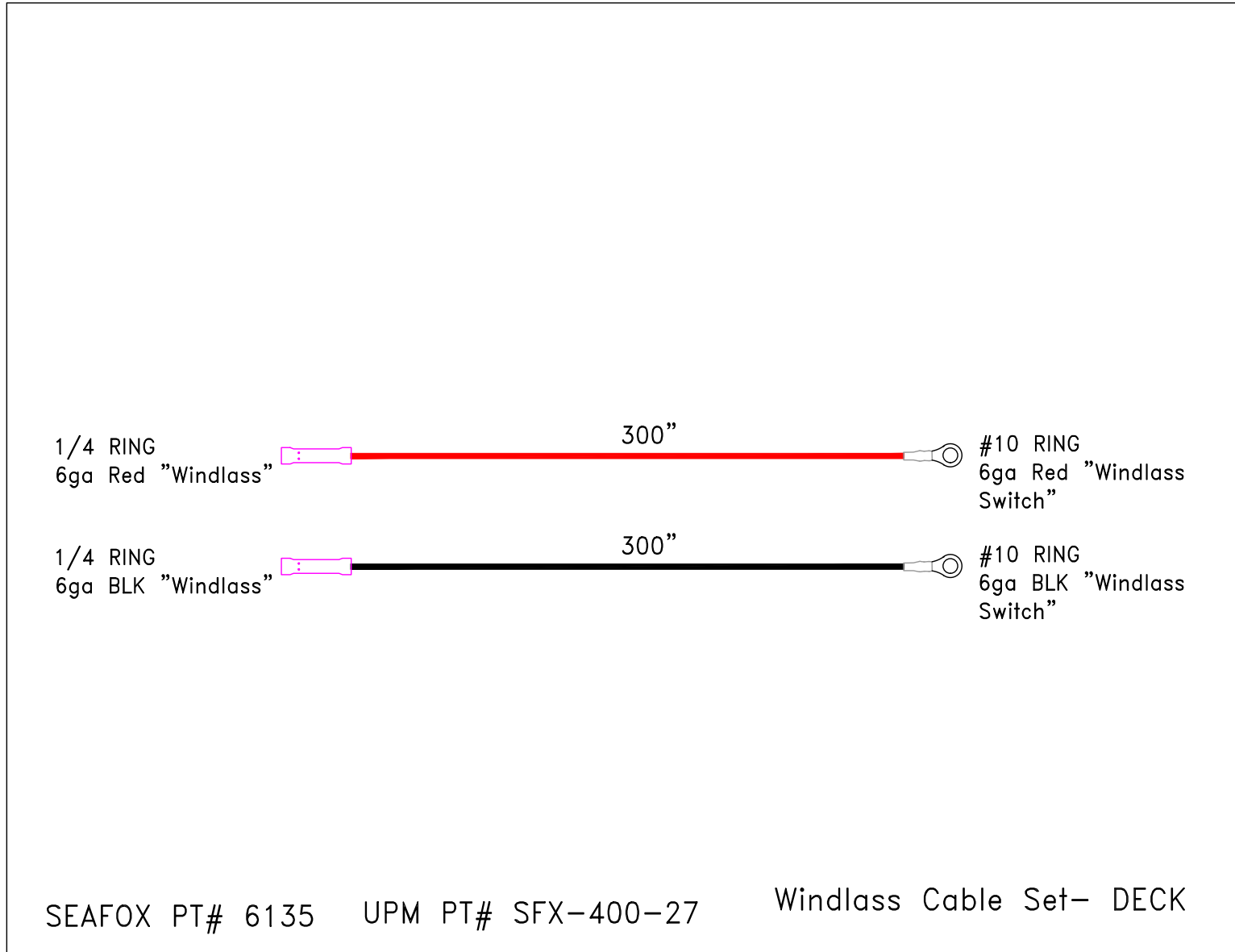



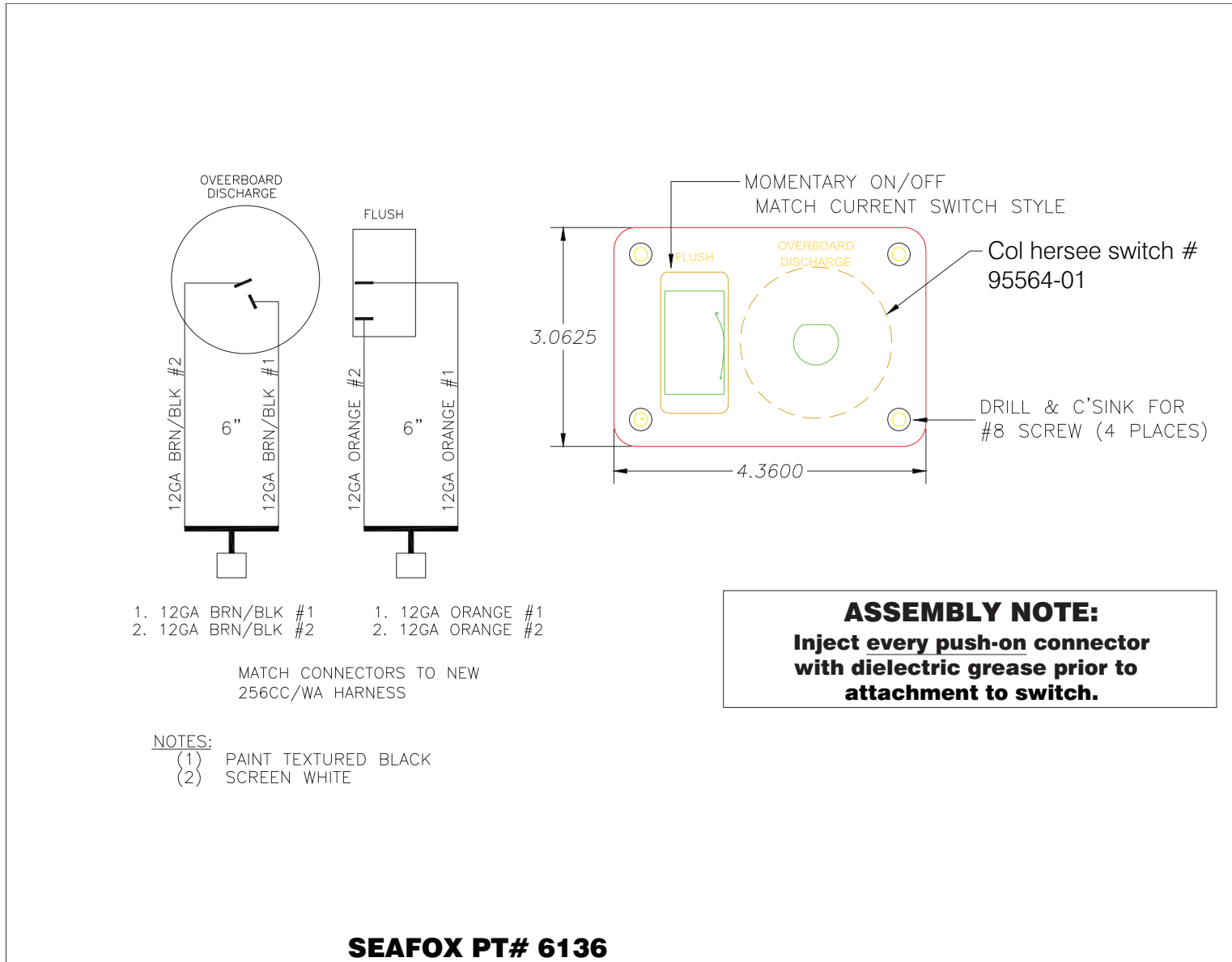



HEAD PANEL SWITCH ORB (P/N 6136) – OPTIONAL



HARNES STEREO KICKER CON 2016 (P/N 6851) – OPTIONAL

NOTES:

- (1) SPLICE CONNECTION IS SOLDER DIPPED AND INSULATED WITH ADHESIVE-LINED HEAT-SHRINK
- (2) TERMINAL LEGEND:
-  = ADHESIVE-LINED CRIMP CONNECTOR
 -  = NON-INS 1/4" FEM. QUICK CONNECTOR W/ DBL-WALL SHRINK
 -  = NON-INS 0.205" FEM. QUICK CONNECTOR W/ DBL-WALL SHRINK
 -  = #8 SNAP SPADE W/ DBL-WALL SHRINK
 -  = 0.156 NON-INS MALE W/ BLUE INSULATOR
 -  = 0.156 NON-INS FEMALE W/ BLUE INSULATOR
 -  = RING TERMINAL W/ ADHESIVE-LINED SHRINK OR SOLDER DIPPED AND ADHESIVE-LINED SHRUNK
- (3) " " = TAGGING TEXT

B - 12WAY ML-II PLUG

1	----
2	----
3	16Ga GREEN
4	16Ga GRN/BLK
5	16Ga GRAY
6	16Ga GRY/BLK
7	16Ga PURPLE
8	16Ga PUR/BLK
9	----
10	16Ga WHITE
11	16Ga WHT/BLK
12	----

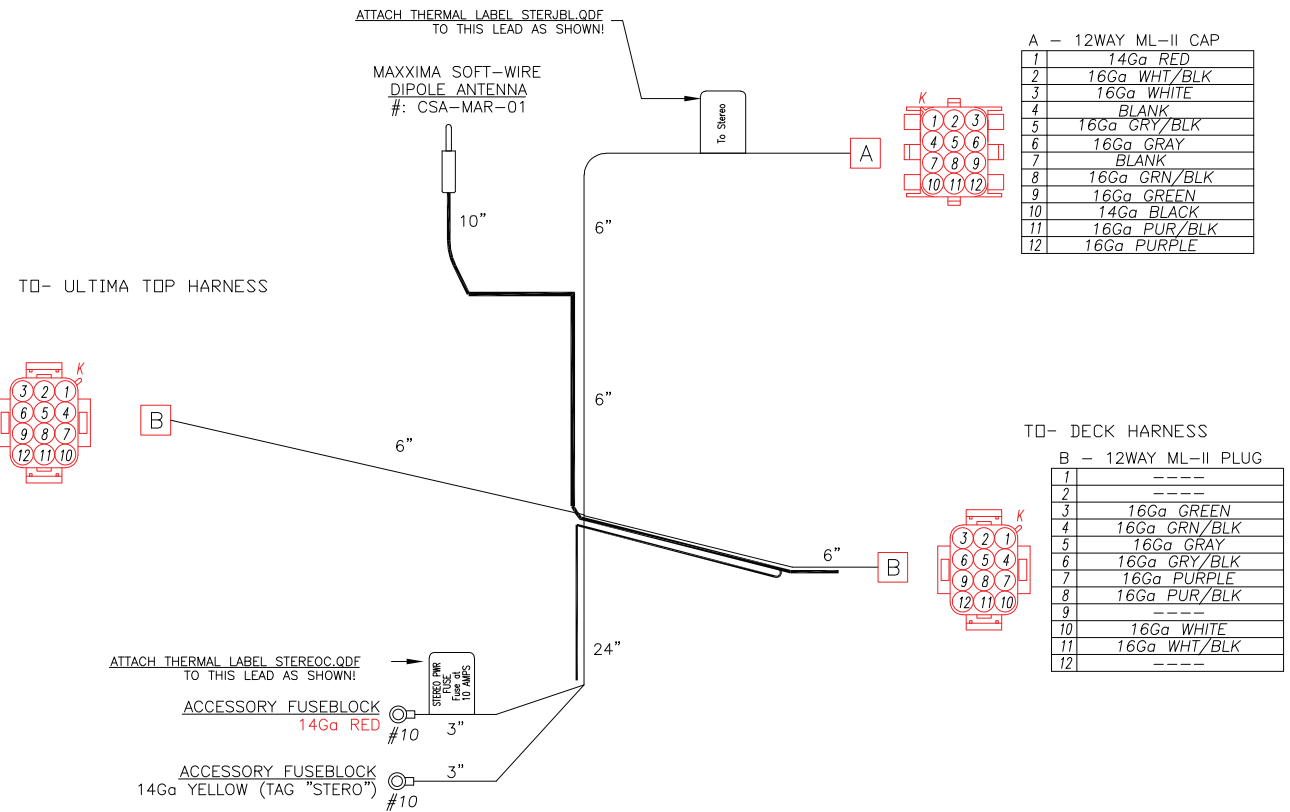

SEAFXDX PT# 6851

HARNES STEREO KICKER DECK 2016 (P/N 6852) – OPTIONAL

CUSTOMER SEAFOX BOAT CO.

PART # SF# 6852-UPM# SFX-489-13

FILENAME _____



W/O # _____

DUE DATE _____

MODEL ALL CENTER CONSOLES

DESCRIPTION HARNES DECK SPEAKER W/LED

NOTES:

-  = NON-INS 1/4" FEM. QUICK CONNECTOR W/ DBL-WALL SHRINK
-  = NON-INS BUTT CONNECTOR W/ DBL-WALL SHRINK

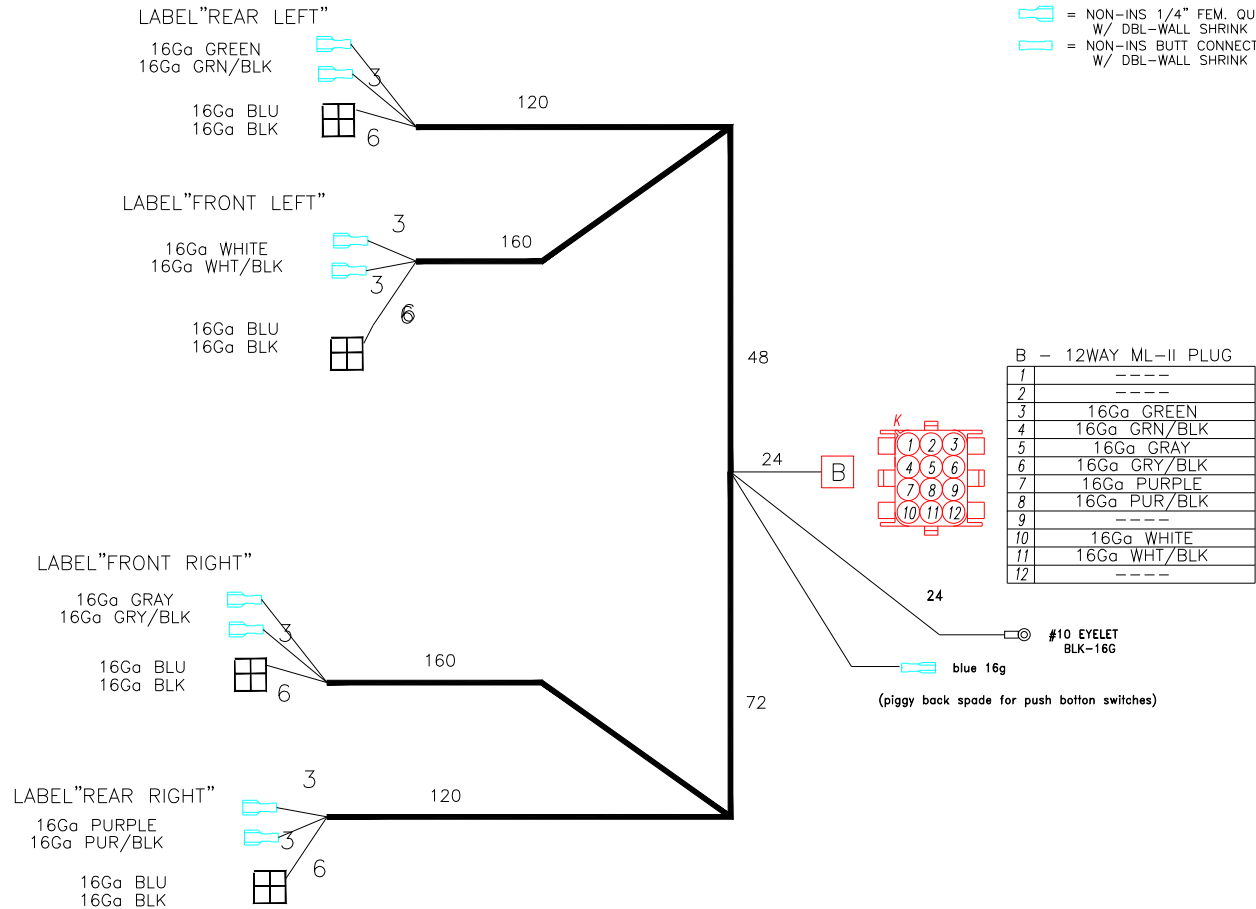

HEAD PANEL SWITCH ORB (P/N 6870) – OPTIONAL

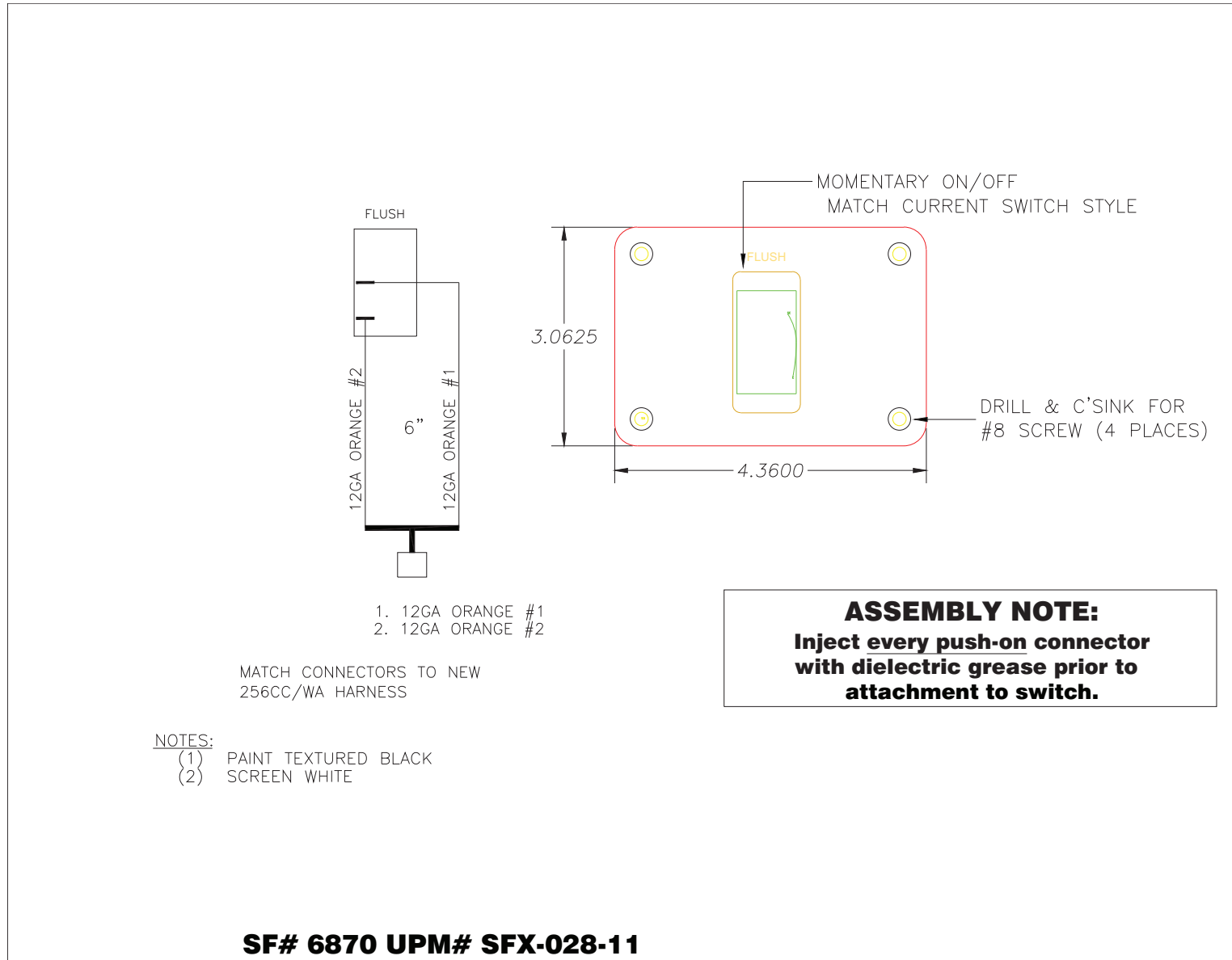

HEAD HARNESS ORB (P/N 6874) – OPTIONAL

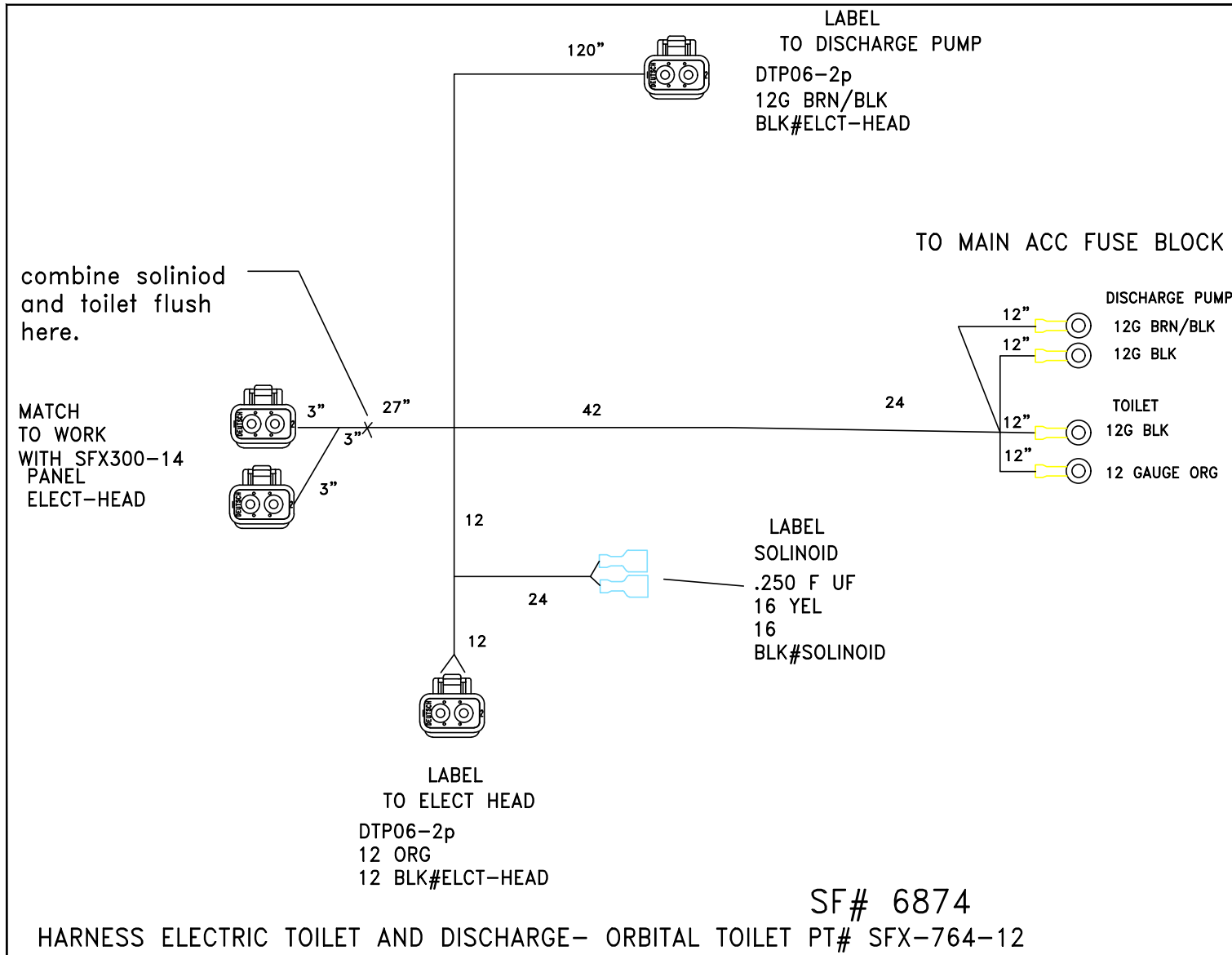

U PANEL SWITCH/HARNESS ULTIMA (P/N 7277) – OPTIONAL

SF# 7277 UPM#SFX-180-099B
HARNESS/ PANEL KIT 22-26FT-MY18

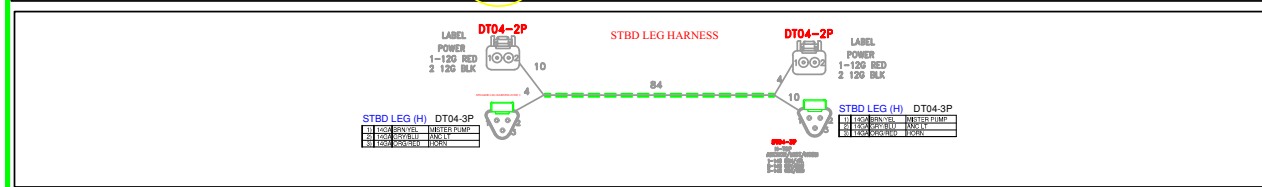
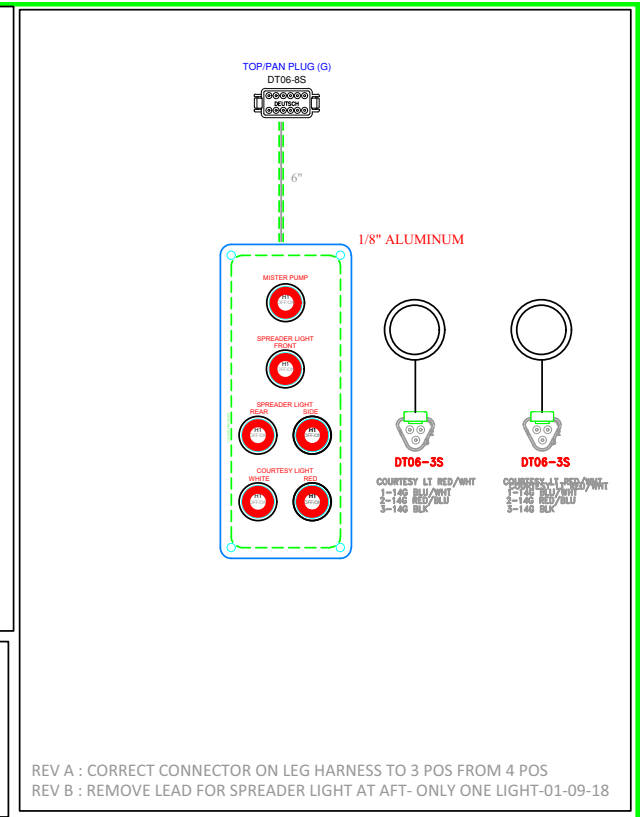
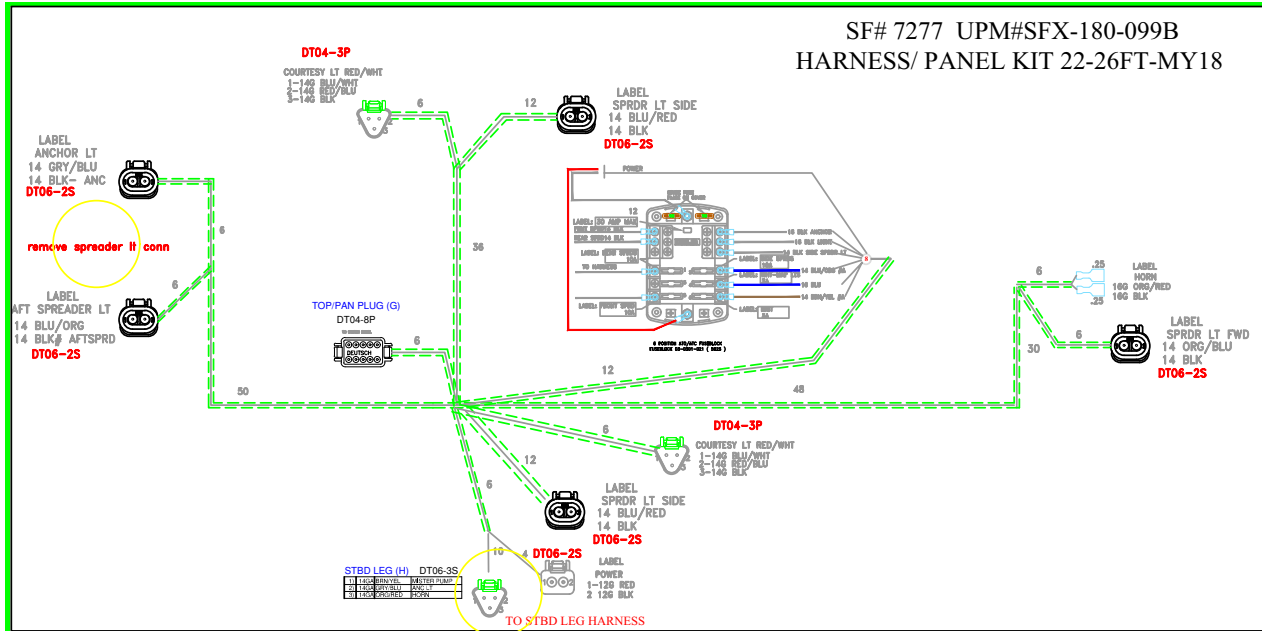

SEA FOX
BOAT WORKS

Sea Fox Boat Company, Inc.
2550 Highway 52
Moncks Corner, SC 29461-5024

Telephone: 843-761-6090
www.seafoxboats.com

Ken Cook Co.
Printed in U.S.A.
Rev 0224